



GUORUI HYDRAULICS
INNOVATION LEADS THE FUTURE

Technical Information

Orbital Motors

GM/GP/GPH/GR/GRA/GRS/GH/GS/GT/GV

GFA/GFB/GFD/GFE/GFF/GFK/GGM

GKM/GKA/GKB/GKC/GKT/GKS/GWD/GWH/GBD





GUORUI HYDRAULICS

Innovation Leads the Future

GRH try our best to create more value for you with products and service

Guorui Hydraulics

About GRH

GRH was established in 1986, focusing on providing customers with quality hydraulic components and solutions to hydraulic system in the applications of engineering machinery, mobile industries, agricultural machinery, aviation, mining, and other fields. Main products include gear pump, gear motor, flow divider, orbital motor, load sensing proportional valve, monoblock valve, sectional valve, manifold assembly and hydraulic power unit as well.

Long-term Development Strategy

Reducing emissions by new energy is one of GRH's long-term strategies. GRH will be providing innovative technologies, products and services for the global development of new energy, moving towards a century development strategy, and writing a century-new chapter in the hydraulic field.



Innovation Leads the Future

Through a few decades of development, GRH has built an intelligent manufacturing factory, gathering international R&D talents, accumulating rich R&D and manufacturing experience, possessing independent intellectual property rights, continuously providing customers with new products and technologies, and creating value for all of the customers.

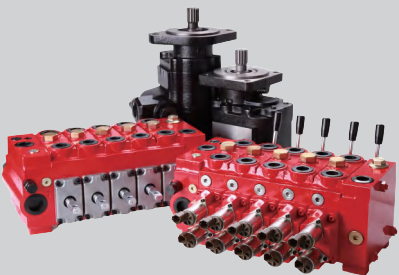

















Orbital Motors

GM	GM Series Orbital Motors	06-13
	Speed 	2450 RPM
	Torque 	88 Nm
GP	GP Series Orbital Motors	14-30
	Speed 	1815 RPM
	Torque 	640 Nm
GPH	GPH Series Orbital Motors	31-43
	Speed 	1815 RPM
	Torque 	640 Nm
GR	GR Series Orbital Motors	44-58
	Speed 	970 RPM
	Torque 	690 Nm
★ GRA	GRA Series Orbital Motors	59-63
	Speed 	700 RPM
	Torque 	505 Nm
GRS	GRS Series Orbital Motors	64-76
	Speed 	970 RPM
	Torque 	690 Nm
GH	GH Series Orbital Motors	77-84
	Speed 	445 RPM
	Torque 	1040 Nm
GS	GS Series Orbital Motors	85-97
	Speed 	1000 RPM
	Torque 	990 Nm
GT	GT Series Orbital Motors	98-110
	Speed 	775 RPM
	Torque 	1470 Nm
GV	GV Series Orbital Motors	111-119
	Speed 	630 RPM
	Torque 	2110 Nm

Orbital Motors

GFA	GFA Series Orbital Motors	120-133
	Speed	1141 RPM
	Torque	648 Nm
★ GFB	GFB Series Orbital Motors	134-145
	Speed	1141 RPM
	Torque	628 Nm
★ GFD	GFD Series OrbitDI Motors	146-155
	Speed	660 RPM
	Torque	1428 Nm
★ GFE	GFE Series OrbitEI Motors	156-161
	Speed	317 RPM
	Torque	2028 Nm
★ GFF	GFF Series OrbitFI Motors	162-169
	Speed	693 RPM
	Torque	851 Nm
GFK	GFK Series OrbitKI Motors	170-176
	Speed	523 RPM
	Torque	266 Nm
GGM	GGM Series Orbital Motors	177-183
	Speed	5000 RPM
	Torque	12.5 Nm

Orbital Motors

★ GKM	GKM Series Orbital Motors	184-189
	Speed 	1992 RPM
	Torque 	620 Nm
GKA	GKA Series Orbital Motors	190-198
	Speed 	1215 RPM
	Torque 	930 Nm
GKB	GKB Series Orbital Motors	199-207
	Speed 	697 RPM
	Torque 	1181 Nm
GKC	GKC Series Orbital Motors	208-213
	Speed 	866 RPM
	Torque 	1875 Nm
GKS	GKS Series Orbital Motors	214-216
	Speed 	677 RPM
	Torque 	770 Nm
GWD	GWD Series Orbital Motors	217-224
	Speed 	490 RPM
	Torque 	1237 Nm
GWH	GWH Series Orbital Motors	225-227
	Speed 	830 RPM
	Torque 	1019 Nm
GBD	GBD Series Orbital Motors	228-229
	Speed 	250 RPM
	Torque 	1500 Nm

GM Series Hydraulic Motors

Options

- Flange connection
- Motor with needle roller bearing
- Side and rear ports
- Shaft seal for high and low pressure
- Straight, splined and tapered shafts
- Speed sensing
- Other special features

Applications

- Conveyors
- Feeding equipment of robots and manipulators
- Metal working machines
- Textile machines
- Agricultural machines
- Food industries
- Lawn mower



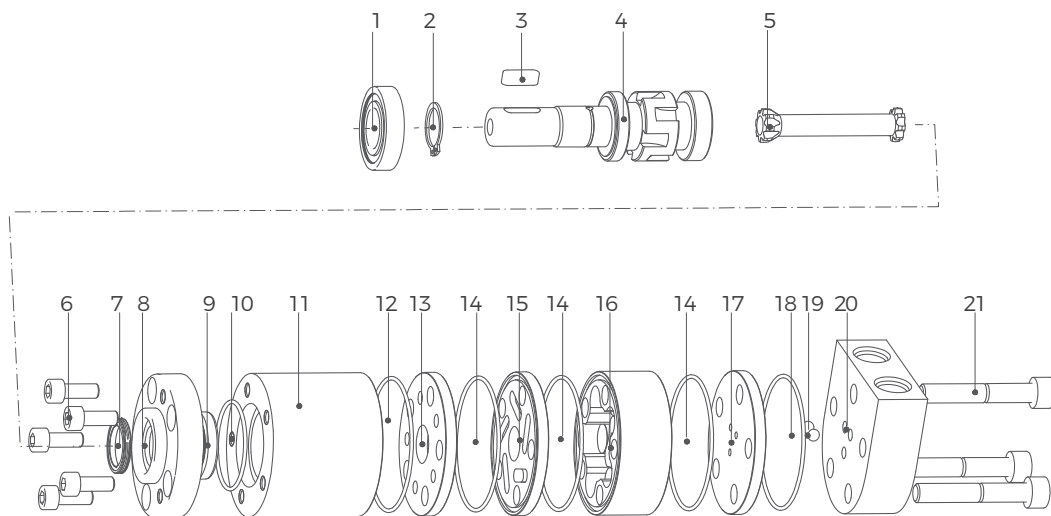

General

Max. Displacement	cm ³ /rev [in ³ /rev]	50 [3.05]
Max. Speed	RPM	2440
Max. Torque	daNm [lb-in]	cont.: 4.6 [410] int.: 8.8 [780]
Max. Output	kW [HP]	3.2 [4.3]
Max. Pressure Drop	bar [PSI]	cont.: 105 [1500] int.: 140 [2030]
Max. Oil Flow	lpm [GPM]	25 [6.6]
Min. Speed	RPM	20
Pressure Fluid		Mineral based- HLP (DIN 51524) or HM (ISO 6743/4)
Temperature Range	°C [°F]	-40 –140 [-104 –284]
Optimal Viscosity Range	mm ² /s [SUS]	20 –75 [98 –347]
Filtration		ISO code: 20/16 (Min. recommended fluid filtration of 25 microns)

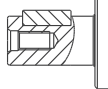

- | | | | | |
|--------------------------|-----------------------|---------------------|---------------------|------------------|
| 1 Tapered roller bearing | 5 Transmission shaft | 9 Skeleton oil seal | 13 Spacer 1 | 17 Balance plate |
| 2 Shaft retainer | 6 Screw | 10 O-ring | 14 O-ring | 18 O-ring seal |
| 3 Paralleled key | 7 Anti-dust free ring | 11 Housing | 15 Spacer 2 | 19 Steel ball |
| 4 Output shaft | 8 Front cover | 12 O-ring | 16 Rotor and stator | 20 Rear cover |
| | | | | 21 Screw |

Ordering Code

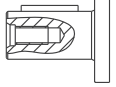
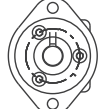
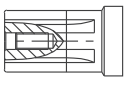
GM SERIES		DISP		FLANGE		SHAFT		PORTS		ROTATION		PAINT		FUNCTION	
CODE	DISP cm ³ /rev [in ³ /rev]	CODE	FLANGE	CODE	SHAFT	CODE	PORTS	CODE	ROTATION	CODE	PAINT	CODE	FUNCTION		
08	8.2 [0.5]	B4	3-M6 Circle, pilot Ø31.5x5 	SS	Shaft Ø16, parallel key 5x5x6 	GA	G3/8, G1/8	A	Standard	A	No Paint	A	Standard		
12.5	12.9 [0.77]	B5	3-1/4-28UNF Circle, pilot Ø31.5x5 	ST	Shaft Ø15.85, parallel key 4.8x4.8x19.05 	U8	9/16-18UNF, 3/8-24UNF	R	Opposite	B	Blue	N	Big radial force		
20	19.9 [1.22]	AD	2-Ø9 Rhomb, pilot Ø63x2 	RK	Shaft Ø16.5, splined B7x14 DIN5482 	GB	End port G3/8, G1/8			C	Black	D	No case drain		
32	31.6 [1.93]					U9	End port 9/16-18UNF, 3/8-24UNF			S	Silver grey	F	Free running		
40	39.8 [2.43]											L	Low speed		
50	50.3 [3.08]											V	High Temp.		
												S	Low Temp.		

Specifications

Type		GM8	GM12.5	GM20	GM32	GM40	GM50
Displacement, cm ³ /rev [in ³ /rev]		8.2[.50]	12.5[.77]	19.9[1.22]	31.6[1.93]	39.8[2.43]	50[3.08]
Max. Speed	Cont.	1950	1550	1000	630	500	400
RPM	Int.*	2450	1940	1250	800	630	500
Max. Torque	Cont.	1.1[95]	1.6[140]	2.5[220]	4.03501	4.5[400]	4.6[410]
daNm [lb-in]	Int.*	1.5[135]	2.3[200]	3.5[310]	5.7[500]	7.0[620]	8.8[780]
	Peak**	2.1[187]	3.3[293]	5.1[453]	6.4[568]	8.2[725]	10.0[885]
Max. Output	Cont.	1.8[2.4]	2.4[3.2]	2.4[3.2]	2.4[3.2]	2.2[3.0]	1.8[2.4]
kW [HP]	Int.*	2.6[3.5]	3.2[4.3]	3.2[4.3]	3.2[4.3]	3.2[4.3]	3.2[4.3]
Max. Pressure Drop	Cont.	100[1450]	100[1450]	100[1450]	100[1450]	90[1310]	70[1020]
bar [PSI]	Int.*	140[2030]	140[2030]	140[2030]	140[2030]	140[2030]	140[2030]
	Peak**	200[2900]	200[2900]	200[2900]	160[2900]	160[2900]	160[2900]
Max. Oil Flow	Cont.	16[4.2]	20[5.3]	20[5.3]	20[5.3]	20[5.3]	20[5.3]
lpm [GPM]	Int.*	20[5.3]	25[6.6]	25[6.6]	25[6.6]	25[6.6]	25[6.6]
Max. Inlet Pressure	Cont.	140[2030]	140[2030]	140[2030]	140[2030]	140[2030]	140[2030]
bar [PSI]	Int.*	175[2540]	175[2540]	175[2540]	175[2540]	175[2540]	175[2540]
	Peak**	225[3260]	225[3260]	225[3260]	225[3260]	225[3260]	225[3260]
Max. Return Pressure	Cont. 0-100 RPM	140[2030]	140[2030]	140[2030]	140[2030]	140[2030]	140[2030]
without Drain Line	Cont.100-400 RPM	105[1500]	105[1500]	105[1500]	105[1500]	105[1500]	105[1500]
bar [PSI]	Cont. 400-800 RPM	50[725]	50[725]	50[725]	50[725]	50[725]	50[725]
Max. Pressure	Cont. >800 RPM	20[290]	20[290]	20[290]	-	-	-
in Drain Line, bar [PSI]	int.* 0-max. RPM	140[2030]	140[2030]	140[2030]	140[2030]	140[2030]	140[2030]
Max. Return Pressure	Cont.	140[2030]	140[2030]	140[2030]	140[2030]	140[2030]	140[2030]
with Drain Line	Int.*	175[2540]	175[2540]	175[2540]	175[2540]	175[2540]	175[2540]
bar [PSI]	Peak**	225[3260]	225[3260]	225[3260]	225[3260]	225[3260]	225[3260]
Max. Starting Pressure with Unloaded Shaft, bar [PSI]		4[60]	4[60]	4[60]	4[60]	4[60]	4[60]
Min. Starting Torque	At max. press. drop Cont.	0.7[60]	1.2[105]	2.1[185]	3.4[300]	3.8[335]	4.1[365]
daNm [lb-in]	At max. press. drop Int.*	1.0[90]	1.7[150]	2.9[255]	4.8[425]	6.2[550]	7.9[700]
Min. Speed, RPM		50	40	30	30	25	20
Weight, kg [lb] For "F" flange: +0,200 [.441]	GM	1.9[4.2]	2.0[4.41]	2.1[4.63]	2.2[4.85]	2.3[5.07]	2.5[5.51]

Function Diagrams

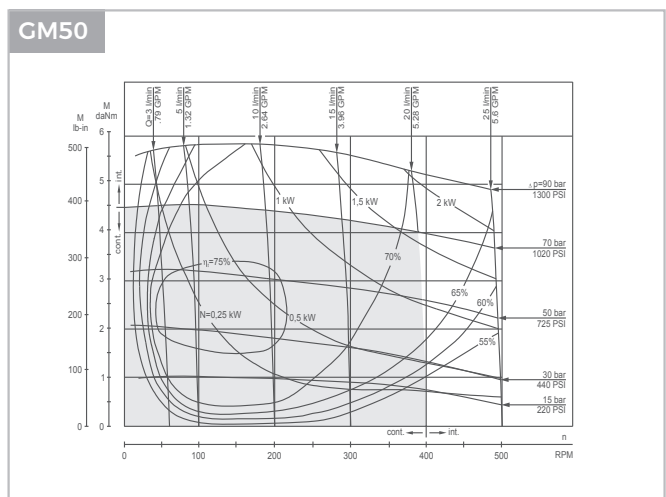
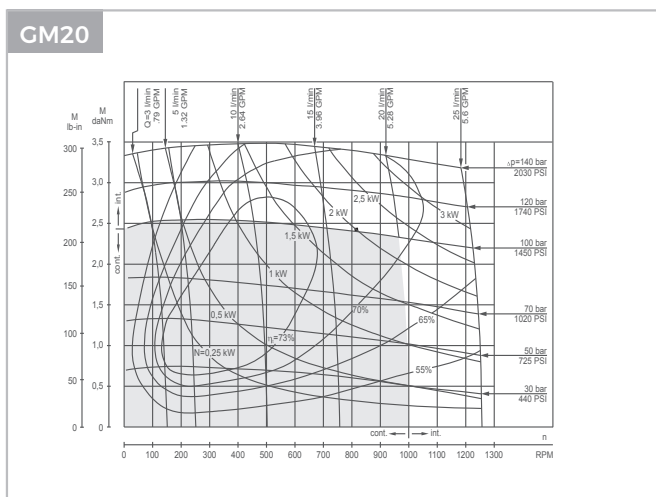
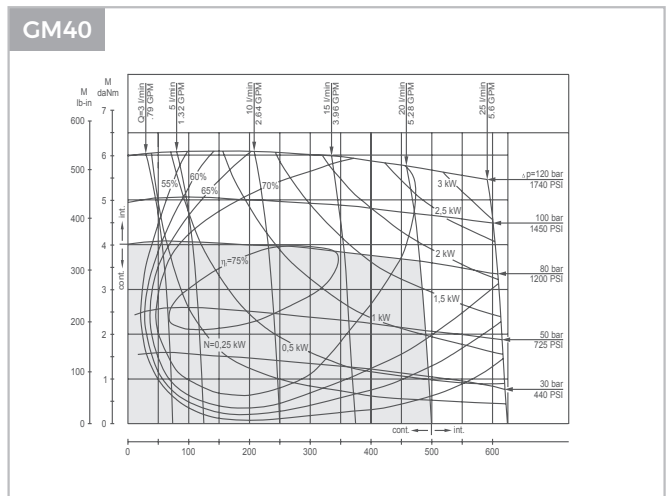
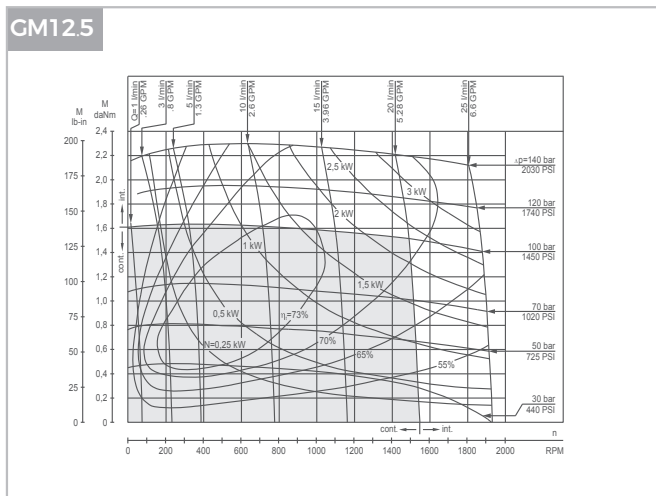
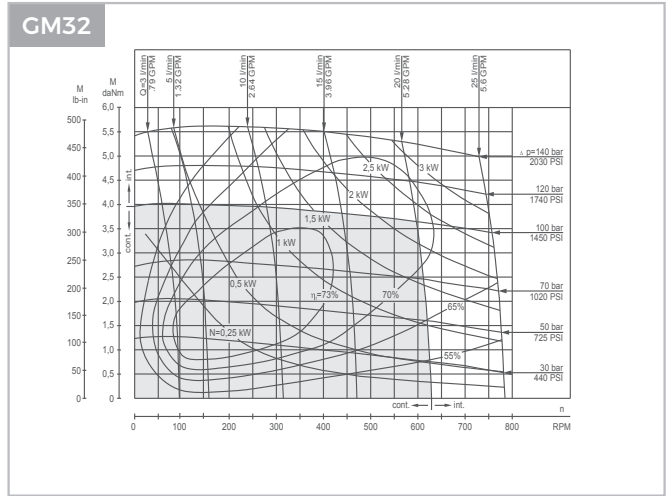
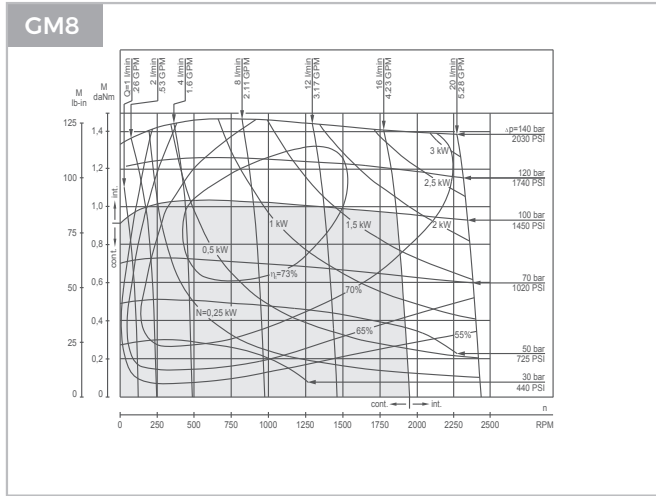

The function diagrams data is for average performance of randomly selected motors at backpressure. 5÷10 bar [72.5÷145 PSI] and oil with viscosity of 32 mm²/s [150 SUS] at 50°C [122°F].

GM Dimensions and Mountings

Model A

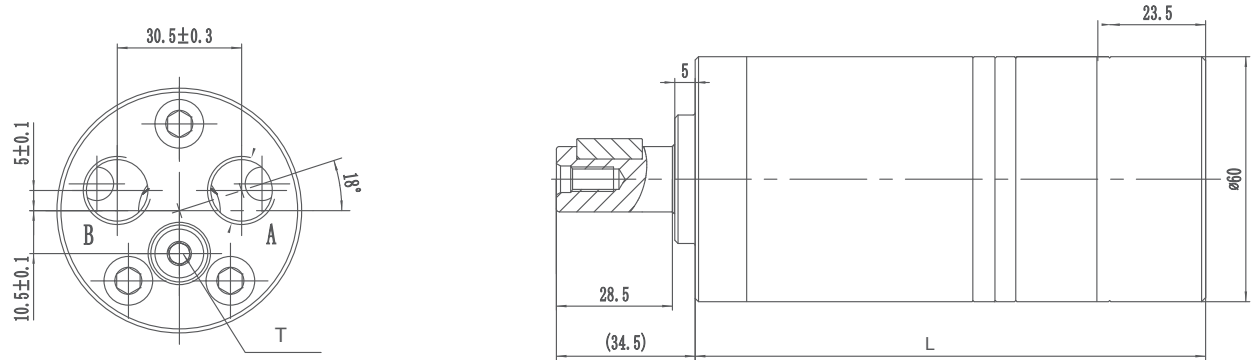

Model B

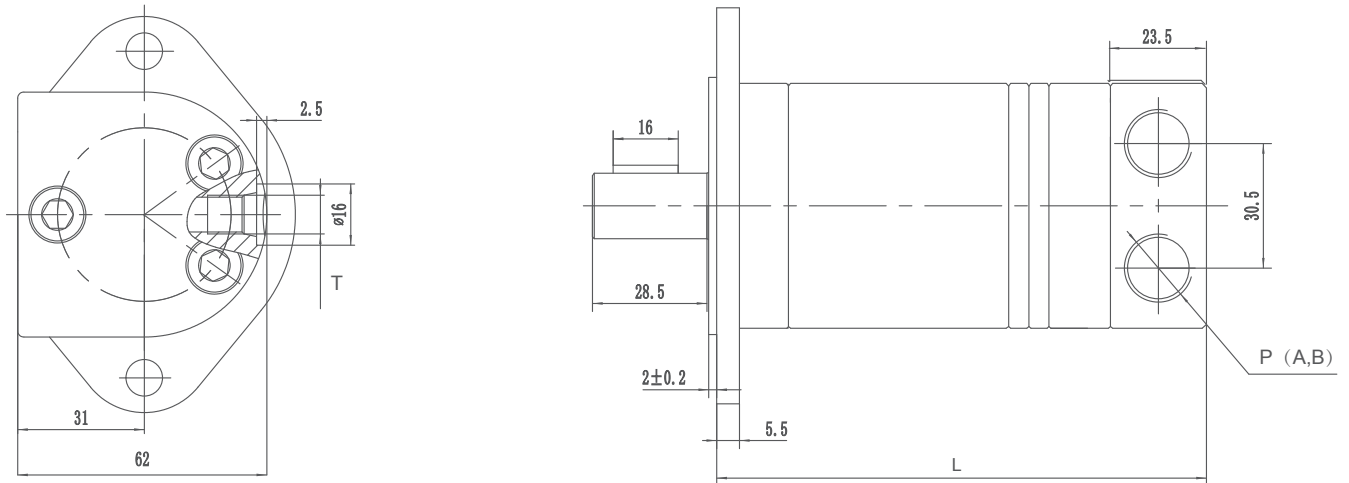

Model	Model A	Model B
	L(mm)	L(mm)
GM8	109	105
GM12.5	111	107
GM20	114	110
GM32	119	115
GM40	122	118
GM50	127	123

Mounting	GA (depth)	U8 (depth)	GB (depth)	U9 (depth)
P(A, B)	G3/8 (12)	9/16-18UNF (12)	End port G3/8 (12)	End port 9/16-18UNF (12)
T	G1/8 (8)	3/8-24UNF (8)	G1/8 (8)	3/8-24UNF (8)

GM Flange Covers Dimensions

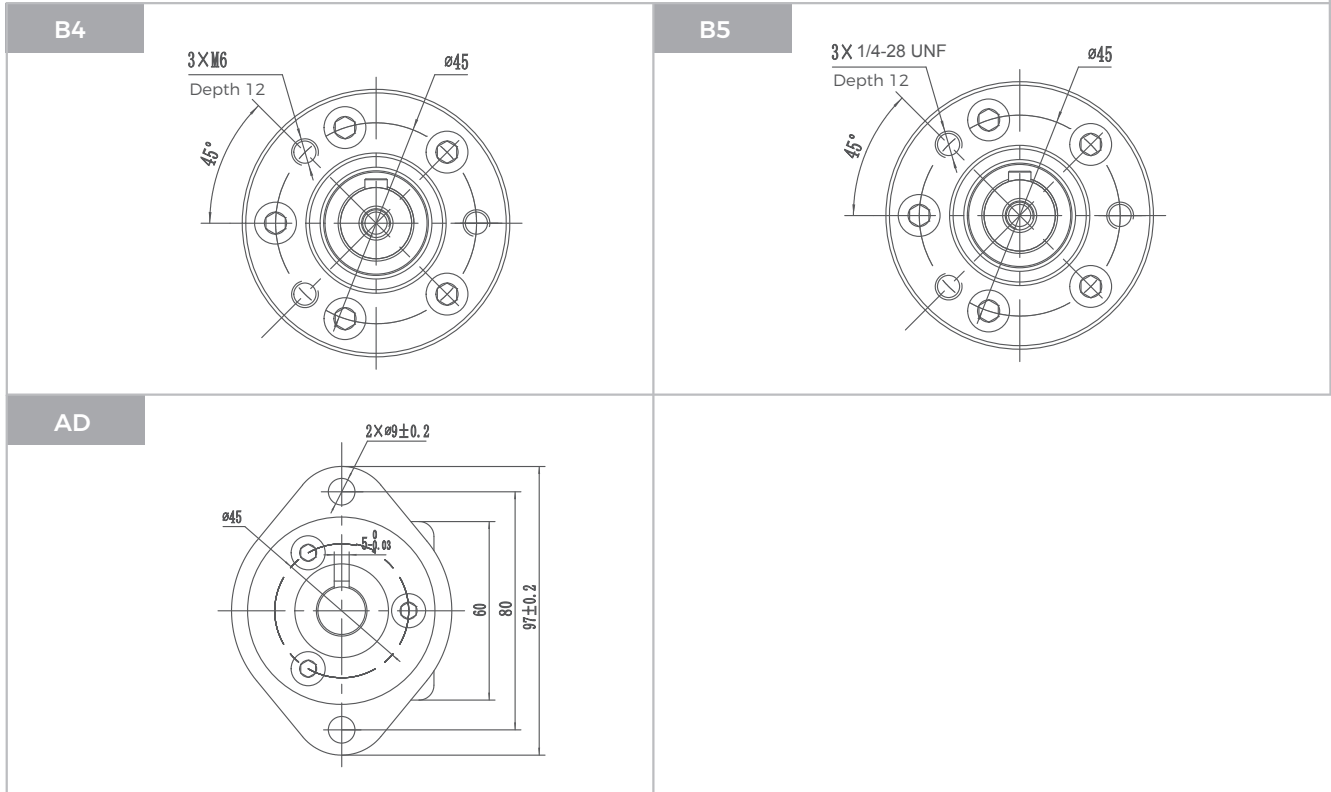

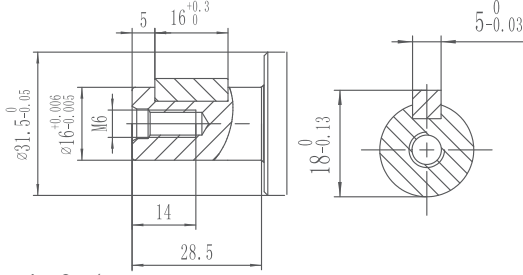
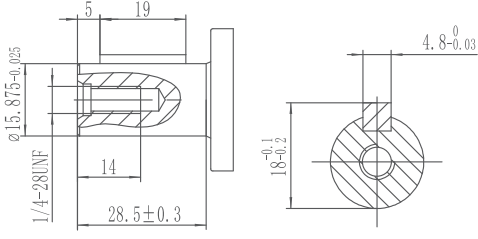
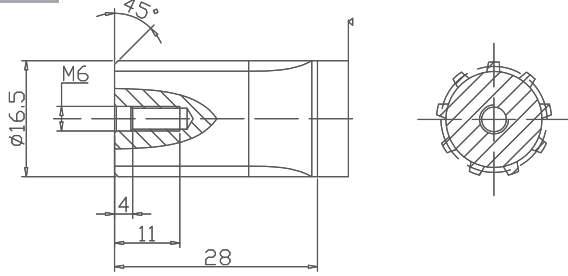

GM Shafts Dimensions

<p>SS</p>  <p>Straight shaft $\varnothing 16$ Parallel key 5 x 5 x 16</p>	<p>ST</p>  <p>Straight shaft $\varnothing 15.875$ Parallel key 4.8 x 4.8 x 19.05</p>
<p>RK</p>  <p>Splined shaft $\varnothing 16.5$ B7 x 14 DIN5482</p>	

GM Series Hydraulic Motors

Permissible shaft seal pressure

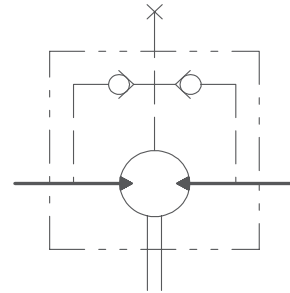
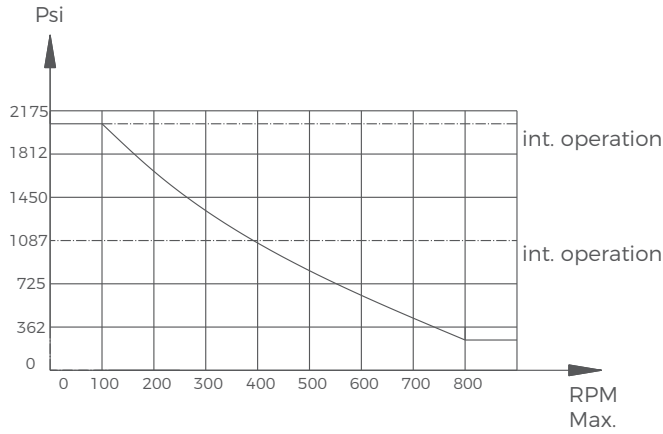

GM with standard shaft seal check valves and without use of drain connection:
The pressure on the shaft seal never exceeds the pressure in the return line. GM with standard shaft seal, check valves and with drain connection: The shaft seal pressure equals the pressure on the drain line.

Drain Port

In applications without drain line, output shaft seal exceeds a bit of the pressure in the return line. In applications using the drain line, the pressure of output shaft seal equals the pressure in drain line.

Standard direction of shaft rotation: Standard

When facing shaft end of motor, shaft to rotate:
Clockwise. When port "A" is pressurized.
Counter-clockwise port "B" is pressurized.

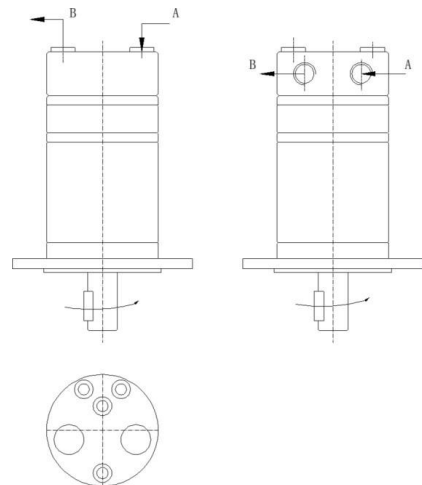

Axial and radial force

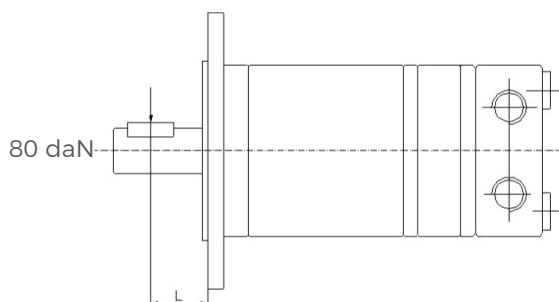

$$Fr = \frac{600}{n} * \frac{13040}{61.5 + L} \text{ (daN)}$$

Fr =Radial Force (daN)

L =Distance (mm)

n =Speed (rpm)

Rhomb flange L=15mm

Square flange L=20mm

GP Series Hydraulic Motors

Options

- Flange connection
- Motor with needle roller bearing
- Side and rear ports
- Shaft seal for high and low pressure
- Straight, splined and tapered shafts
- Metric and BSPP ports
- Other special features

Applications

- Conveyors
- Feeding equipment of robots and manipulators
- Metal working machines
- Textile machines
- Agricultural machines
- Food industries
- Lawn mower







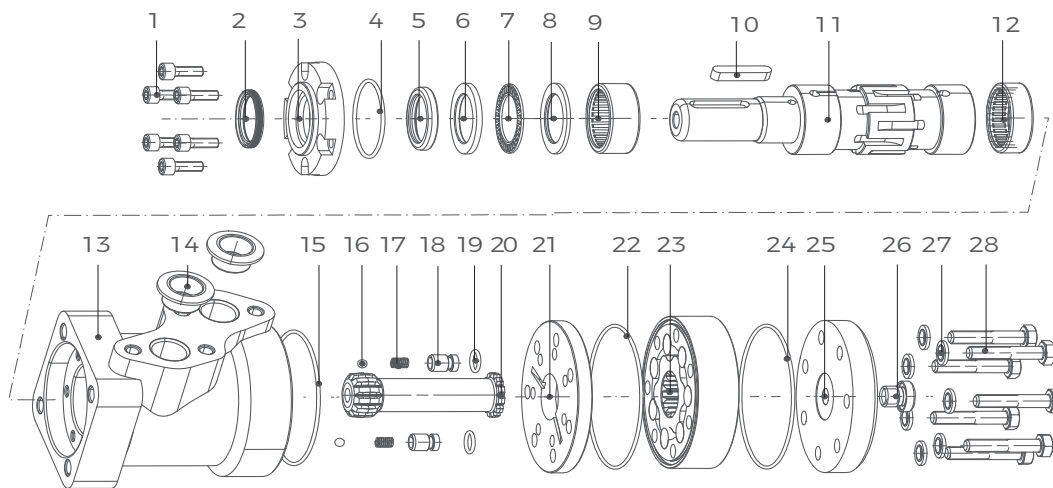



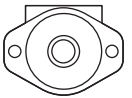

General

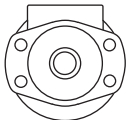
Max. Displacement	cm ³ /rev [in ³ /rev]	623,6 [38.05]
Max. Speed	RPM	1815
Max. Torque	daNm [lb-in]	cont.: 44 [3895] int.: 64 [5565]
Max. Output	kW [HP]	12.8 [17.1]
Max. Pressure Drop	bar [PSI]	cont.:140 [2030] int.:175 [2540]
Max. Oil Flow	lpm [GPM]	75 [19.8]
Min. Speed	RPM	10
Pressure Fluid		Mineral based- HLP [DIN 51524] or HM [ISO 6743/4]
Temperature Range	°C [°F]	-40 -140 [-104-284]
Optimal Viscosity range	mm ² /s [SUS]	20-75[98-347]
Filtration		ISO code 20/16 [Min. recommended fluid filtration of 25 microns]

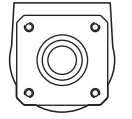

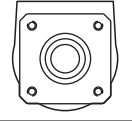
- | | | | | | |
|------------------|-------------------------|--------------------------|-----------------------|---------------------|-----------|
| 1 Bolt | 6 Bearing retainer | 11 Output shaft | 16 Steel ball | 21 Spacer | 26 Plug |
| 2 Anti-dust ring | 7 Flat bearing | 12 Needle roller bearing | 17 Spring | 22 O-ring seal | 27 Washer |
| 3 Front cover | 8 Bearing retainer | 13 Housing | 18 Check valve | 23 Rotor and stator | 28 Screw |
| 4 O-ring seal | 9 Needle roller bearing | 14 Rubber plug | 19 O-ring seal | 24 O-ring seal | |
| 5 Shaft seal | 10 Parallel key | 15 O-ring seal | 20 Transmission shaft | 25 Rear cover | |

Ordering Code

CP SERIES		DISP		FLANGE		SHAFT		PORTS		ROTATION		PAINT		FUNCTION		
CODE	DISP cm ³ /rev [in ³ /rev]	CODE	FLANGE	CODE	SHAFT	CODE	ROTATION	CODE	PAINT	CODE	FUNCTION					
025	25 [1.52]	A2	2-Hole SAE A, Ø106.4 pilot Ø82.5×2.8 	S1	Shaft Ø25, parallel key 8×7×32 	A	Standard									
032	32 [1.95]			S2	Shaft Ø25.4, parallel key 6.35×6.35×31.75 	R	Opposite									
040	40 [2.44]	A4	4-Hole SAE A, Ø106.4 pilot Ø82.5×2.8 	R1	Shaft Ø25.4, splined tooth SAE6B 											
050	49.5 [3.02]			S3	Shaft Ø25.4, parallel key 6.35×6.35×31.75 											
080	79.2 [4.83]	H4	4-3/8-16UNC square, Ø82.5 pilot Ø44.4×2.8 	S4	Shaft Ø32, parallel key 10×8×45 	B	Blue									
100	99 [6.04]			R2	Shaft Ø31.75, splined tooth 14 - DP 12/24 	C	Black									
125	123.8 [7.55]	H5	4-M10 square, Ø82.5 pilot Ø44.4×2.8 	R3	Long shaft Ø31.75, splinedtooth 14 - DP 12/24 	S	Silver grey									
160	158.4 [9.66]			S5	Shaft Ø31.75, parallel key 7.96×7.96×31.75 											
200	198 [12.1]			T1	Tapered shaft Ø28.56, parallel key B5×5×14 											
250	247.5 [15.1]			T2	Tapered shaft Ø31.75, paralle key 7.96×7.96×25.4 											
315	316.8 [19.3]															
400	396 [24.16]															
500	495 [30.2]															
630	623.6 [38.05]															

CODE	PORTS
G1	G1/2, G1/4 manifold 4×M8
M1	M22×1.5M14×1.5, manifold 4×M8
U2	7/8-1UNF, 7/16-20UN manifold 4×5/16-18UNCF
U1	7/8-14NPTF, 7/16-20UNF, manifold 4×5/16-18UNC
G2	PT (Rc) 1/2, PT (Rc) 1/4 manifold 4×M8

Specifications

Technical data for GP with , Ø25,Ø25.4 straight, Ø25.4 splined and Ø28.56 tapered shaft

Type		GP25	GP32	GP40	GP50	GP80	GP100	GP125
Displacement, cm ³ /rev [in ³ /rev]		25[1.52]	32[1.95]	40[2.44]	49.5[3.02]	79.2[4.83]	99[6.04]	123.8[7.55]
Max. Speed,	Cont	1600	1560	1500	1210	755	605	486
RPM	Int*	1815	1720	1750	1515	945	755	605
Max. Torque	Cont	3.3[290]	4.3[380]	6.2[550]	9.4[835]	15.1[1340]	19.3[1710]	23.7[2100]
daNm [lb-in]	Int*	4.7[415]	6.1[540]	8.2[730]	11.9[1050]	19.5[1725]	23.7[2100]	29.8[2640]
	Peak**	6.7[595]	8.6[760]	10.7[950]	14.3[1285]	22.4[1985]	27.5[2435]	36.5[3235]
Max. Output	Cont	4.5[6.0]	5.8[7.8]	8.4[11.5]	10.1[13.5]	10.2[13.7]	10.5[14.1]	10.2[13.7]
kW [HP]	Int*	6.1[8.2]	7.8[10.5]	11.6[15.5]	12.2[16.1]	12.5[16.8]	12.8[17.1]	12[16.1]
Max. Pressure Drop	Cont	100[1450]	100[1450]	120[1750]	140[2030]	140[2030]	140[2030]	140[2030]
bar [PSI]	Int*	140[2030]	140[2030]	155[2250]	175[2540]	175[2540]	175[2540]	175[2540]
	Peak**	225[3260]	225[3260]	225[3260]	225[3260]	225[3260]	225[3260]	225[3260]
Max. Oil Flow	Cont	40[10.5]	50[13.2]	60[15.9]	60[15.9]	60[15.9]	60[15.9]	60[15.9]
lpm [GPM]	Int*	45[11.9]	55[14.5]	70[18.5]	75[19.8]	75[19.8]	75[19.8]	75[19.8]
Max. Inlet Pressure	Cont	175[2540]	175[2540]	175[2540]	175[2540]	175[2540]	175[2540]	175[2540]
bar [PSI]	Int*	200[2900]	200[2900]	200[2900]	200[2900]	200[2900]	200[2900]	200[2900]
	Peak**	225[3260]	225[3260]	225[3260]	225[3260]	225[3260]	225[3260]	225[3260]
Max. Return Pressure	Cont	175[2540]	175[2540]	175[2540]	175[2540]	175[2540]	175[2540]	175[2540]
without Drain Line	Int*	200[2900]	200[2900]	200[2900]	200[2900]	200[2900]	200[2900]	200[2900]
bar [PSI]	Peak**	225[3260]	225[3260]	225[3260]	225[3260]	225[3260]	225[3260]	225[3260]
Max. Starting Pressure		10[145]	10[145]	10[145]	10[145]	10[145]	10[145]	9[131]
with Unloaded Shaft, bar [PSI]								
Min. Starting Torque	At max. press. drop Cont	3.0[265]	4.0[355]	5.4[480]	7.8[690]	13.2[1170]	16.6[1470]	20.7[1830]
daNm [lb-in]	At max. press. drop Int*	4.2[370]	5.6[500]	6.8[600]	10[885]	16.8[1490]	21[1860]	26.6[2360]
Min. Spee, RPM		20	15	10	10	10	10	10
Weight, kg [lb] For								
Rear Port + 0.450 [992]	GP	5.6[12.3]	5.6[12.3]	5.7[12.6]	5.8[12.8]	5.9[13.2]	6.1[13.5]	6.2[13.7]



Specifications

Technical data for GP with , Ø25,Ø25.4 straight, Ø25.4 splined and Ø28.56 tapered shaft

Type		GP160	GP200	GP250	GP315	GP400	GP500	GP630
Displacement, cm ³ /rev [in ³ /rev]		158,4[9.66]	198[12.1]	247,5[15.1]	316,8[19.3]	396[24.16]	495[30.2]	623,6[38.05]
Max. Speed,	Cont	378	303	242	190	150	120	95
RPM	Int*	472	378	303	236	189	150	120
Max. Torque	Cont	31,3[2770]	36,6[3240]	38[3360]	38[3360]	36[3190]	39[3452]	44[3895]
daNm [lb-in]	Int*	37,8[3345]	45,6[4035]	58,3[5160]	56[4960]	59[5240]	57[5045]	64[5665]
	Peak**	43,8[3880]	55[4870]	68,5[6060]	85[7505]	85,4[7560]	78[6903]	82[7257]
Max. Output	Cont	10,1[13.5]	10[13.5]	7,5[10]	5,8[7.9]	4,6[6.2]	3,5[4.7]	3,3[4.4]
kW [HP]	Int*	12,1[16.2]	12[16.1]	12[16.1]	9[12.1]	7,8[10.5]	7,2[9.7]	5,6[7.5]
Max. Pressure Drop	Cont	140[2030]	140[2030]	110[1600]	90[1300]	70[1015]	60[870]	55[800]
bar [PSI]	Int*	175[2540]	175[2540]	175[2540]	140[2030]	115[1665]	90[1305]	80[1160]
	Peak**	225[3260]	225[3260]	225[3260]	225[3260]	180[2610]	130[1885]	110[1740]
Max. Oil Flow	Cont	60[15.9]	60[15.9]	60[15.9]	60[15.9]	60[15.9]	60[15.9]	60[15.9]
lpm [GPM]	Int*	75[19.8]	75[19.8]	75[19.8]	75[19.8]	75[19.8]	75[19.8]	75[19.8]
Max. Inlet Pressure	Cont	175[2540]	175[2540]	175[2540]	175[2540]	175[2540]	140[2030]	140[2030]
bar [PSI]	Int*	200[2900]	200[2900]	200[2900]	200[2900]	200[2900]	175[2540]	175[2540]
	Peak**	225[3260]	225[3260]	225[3260]	225[3260]	225[3260]	225[3260]	225[3260]
Max. Return Pressure	Cont	175[2540]	175[2540]	175[2540]	175[2540]	175[2540]	140[2030]	140[2030]
without Drain Line	Int*	200[2900]	200[2900]	200[2900]	200[2900]	200[2900]	175[2540]	175 [2540]
bar [PSI]	Peak**	225[3260]	225[3260]	225[3260]	225[3260]	225[3260]	225[3260]	225[3260]
Max. Starting Pressure		8[116]	7[100]	6[87]	5[73]	5[73]	5[73]	5[73]
with Unloaded Shaft, bar [PSI]								
Min. Starting Torque	At max. press. drop Cont	28,2[2500]	33,5[2950]	33,6[2970]	34,4[3045]	34,5[3050]	36[3180]	41,5[3670]
daNm [lb-in]	At max. press. drop Int*	35,5[3140]	42,6[3770]	54,2[4795]	61,9[5480]	60,8[5390]	54[4780]	62[5480]
Min. Speed, RPM		10	10	10	10	10	10	10
Weight, kg [lb] For								
Rear Port + 0.450 [992]	GP	6,4[14.1]	6,6[14.6]	6,8[15]	7,1[15.6]	7,6[16.8]	8,9[20]	9,5[21.4]

Specifications

Technical data for GP with $\varnothing 31.75$ and $\varnothing 32$ shaft

Type		GP25	GP32	GP40	GP50	GP80	GP100	GP125
Displacement, cm ³ /rev [in ³ /rev]		25[1.52]	32[1.95]	40[2.44]	49.5[3.02]	79.2[4.83]	99[6.04]	123.8[7.55]
Max. Speed, RPM	Cont.	1600	1560	1500	1210	755	605	486
	Int*	1815	1720	1750	1515	945	755	605
Max. Torque daNm [lb-in]	Cont.	3.3[290]	4.3[380]	6.2[550]	9.4[835]	15.1[1340]	19.3[1710]	23.7[2100]
	Int*	4.7[415]	6.1[540]	8.2[730]	11.9[1050]	19.5[1725]	23.7[2100]	29.8[2640]
	Peak**	6.7[595]	8.6[760]	10.7[950]	14.3[1285]	22.4[1985]	27.5[2435]	36.5[3235]
Max. Output kW [HP]	Cont.	4.5[6.0]	5.8[7.8]	8.4[11.5]	10.1[13.5]	10.2[13.7]	10.5[14.1]	10.2[13.7]
	Int*	6.1[8.2]	7.8[10.5]	11.6[15.5]	12.2[16.1]	12.5[16.8]	12.8[17.1]	12[16.1]
Max. Pressure Drop bar [PSI]	Cont.	100[1450]	100[1450]	120[1750]	140[2030]	140[2030]	140[2030]	140[2030]
	Int*	140[2030]	140[2030]	155[2250]	175[2540]	175[2540]	175[2540]	175[2540]
	Peak**	225[3260]	225[3260]	225[3260]	225[3260]	225[3260]	225[3260]	225[3260]
Max. Oil Flow lpm [GPM]	Cont.	40[10.5]	60[13.2]	60[15.9]	60[15.9]	60[15.9]	60[15.9]	60[15.9]
	Int*	45[11.9]	55[14.5]	70[18.5]	75[19.8]	75[19.8]	75[19.8]	75[19.8]
Max. Inlet Pressure bar [PSI]	Cont.	175[2540]	175[2540]	175[2540]	175[2540]	175[2540]	175[2540]	175[2540]
	Int*	200[2900]	200[2900]	200[2900]	200[2900]	200[2900]	200[2900]	200[2900]
	Peak**	225[3260]	225[3260]	225[3260]	225[3260]	225[3260]	225[3260]	225[3260]
Max. Return Pressure without Drain Line bar [PSI]	Cont.	175[2540]	175[2540]	175[2540]	175[2540]	175[2540]	175[2540]	175[2540]
	Int*	200[2900]	200[2900]	200[2900]	200[2900]	200[2900]	200[2900]	200[2900]
	Peak**	225[3260]	225[3260]	225[3260]	225[3260]	225[3260]	225[3260]	225[3260]
Max. Starting Pressure with Unloaded Shaft, bar [PSI]		10[145]	10[145]	10[145]	10[145]	10[145]	10[145]	9[131]
Min. Starting Torque daNm [lb-in]	At max. press. drop Cont.	3.0[265]	4.0[355]	5.4[480]	7.8[690]	13.2[1170]	16.6[1470]	20.7[1830]
	At max. press. drop Int*	4.2[370]	5.6[500]	6.8[600]	10[885]	16.8[1490]	21[1860]	26.6[2360]
Min. Speed, RPM		20	15	10	10	10	10	10
Weight, kg [lb] For Rear Port + 0.450 [992]	GP	5.6[12.3]	5.6[12.3]	5.7[12.6]	5.9[13]	6[13.2]	6.2[13.7]	6.3[13.9]



Specifications

Technical data for GP with $\varnothing 31.75$ and $\varnothing 32$ shaft

Type		GP160	GP200	GP250	GP315	GP400	GP500	GP630
Displacement, cm ³ /rev [in ³ /rev]		158,4[9.66]	198[12.1]	247,5[15.1]	316,8[19.3]	396[24.16]	495[30.2]	623,6[38.05]
Max. Speed,	Cont.	378	303	242	190	150	120	95
RPM	Int*	472	378	303	236	189	150	120
Max. Torque	Cont.	31,3[2770]	36,6[3240]	47[4160]	48[4360]	50[4415]	39[3452]	44[3895]
daNm [lb-in]	Int*	37,8[3345]	45,6[4035]	58,3[5160]	56[4960]	59[5240]	57[5045]	64[5665]
	Peak**	43,8[3880]	55[4870]	68,5[6060]	85[7505]	85,4[7560]	78[6903]	82[7257]
Max. Output	Cont.	10,1[13.5]	10[13.5]	9[12.1]	7,6[10.2]	6,2[8.3]	3,5[4.7]	3,3[4.4]
kW [HP]	Int*	12,1[16.2]	12[16.1]	12[16.1]	9[12.1]	7,8[10.5]	7,2[9.7]	5,6[7.5]
Max. Pressure Drop	Cont.	140[2030]	140[2030]	140[2030]	120[1740]	95[1400]	60[870]	55[800]
bar [PSI]	Int*	175[2540]	175[2540]	175[2540]	140[2030]	115[1670]	90[1305]	80[1160]
	Peak**	225[3260]	225[3260]	225[3260]	225[3260]	180[2610]	130[1885]	110[1740]
Max. Oil Flow	Cont.	60[15.9]	60[15.9]	60[15.9]	60[15.9]	60[15.9]	60[15.9]	60[15.9]
lpm [GPM]	Int*	75[19.8]	75[19.8]	75[19.8]	75[19.8]	75[19.8]	75[19.8]	75[19.8]
Max. Inlet Pressure	Cont.	175[2540]	175[2540]	175[2540]	175[2540]	175[2540]	140[2030]	140[2030]
bar [PSI]	Int*	200[2900]	200[2900]	200[2900]	200[2900]	200[2900]	175[2540]	175[2540]
	Peak**	225[3260]	225[3260]	225[3260]	225[3260]	225[3260]	225[3260]	225[3260]
Max. Return Pressure	Cont.	175[2540]	175[2540]	175[2540]	175[2540]	175[2540]	140[2030]	140[2030]
without Drain Line	Int*	200[2900]	200[2900]	200[2900]	200[2900]	200[2900]	175[2540]	175[2540]
bar [PSI]	Peak**	225[3260]	225[3260]	225[3260]	225[3260]	225[3260]	225[3260]	225[3260]
Max. Starting Pressure		8[116]	7[100]	6[87]	5[73]	5[73]	5[73]	5[73]
with Unloaded Shaft, bar [PSI]								
Min. Starting Torque	At max. press. drop Cont.	28,2[2500]	33,5[2950]	42,8[3790]	4050[45.8]	46,8[4140]	36[3180]	41,5[3670]
daNm [lb-in]	At max. press. drop Int*	35,5[3140]	42,6[3770]	54,2[4795]	5480[61.9]	60,8[5390]	54[4780]	62[5480]
Min. Speed, RPM		10	10	10	10	10	10	10
Weight, kg [lb] For								
Rear Port + 0,450 [992]	GP	6[14.3]	6[14.8]	6,9[15.2]	7,2[15.9]	7,7[17]	9[19.9]	9[21.2]



Function Diagrams

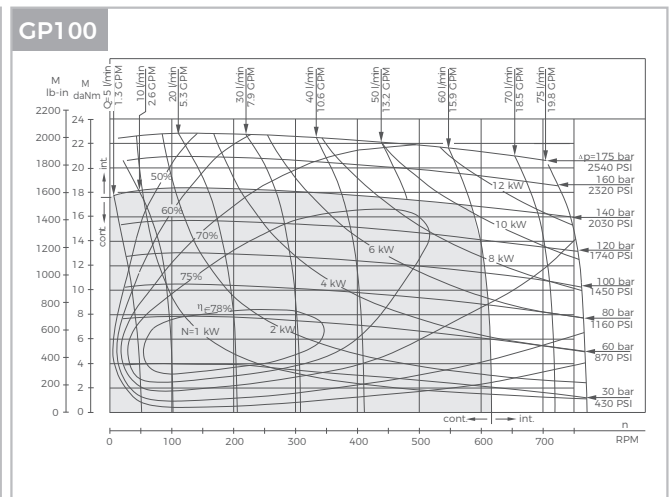
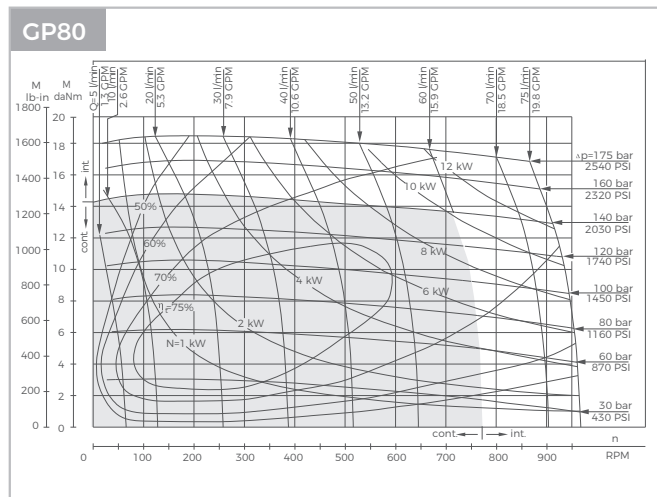
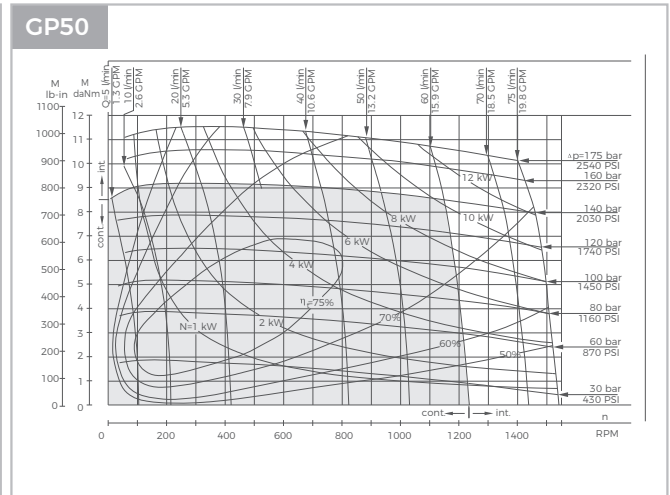
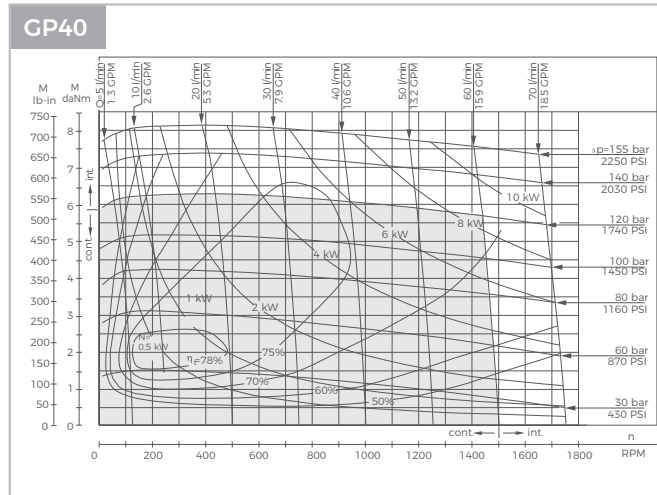
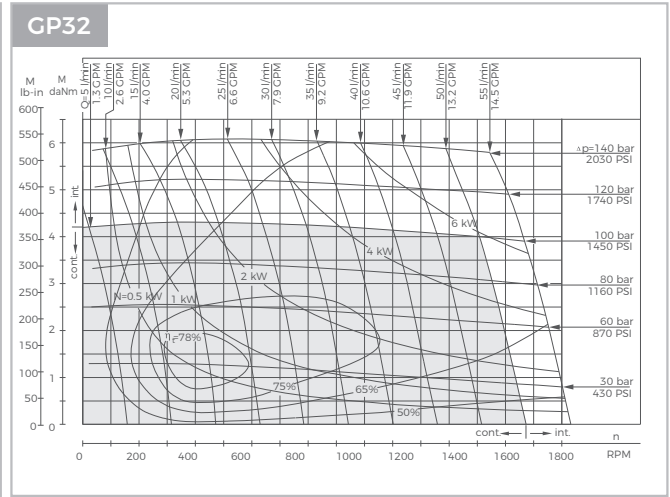
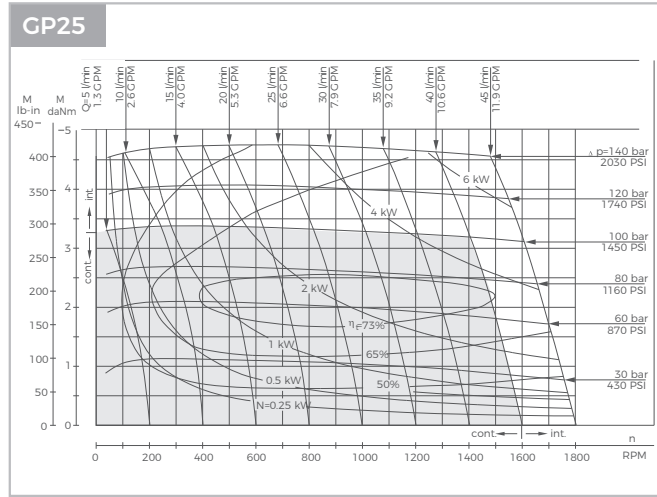

The function diagrams data is for average performance of randomly selected motors at backpressure. 5–10 bar [72.5–145 PSI] and oil with viscosity of 32 mm²/s [150 SUS] at 50°C [122°F].

Function Diagrams

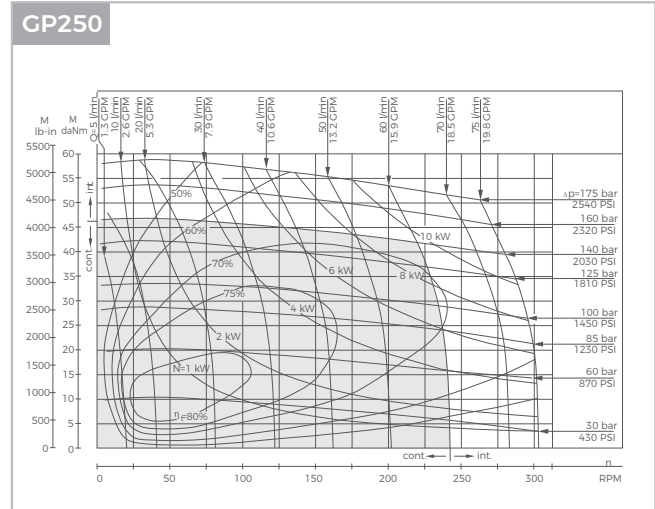
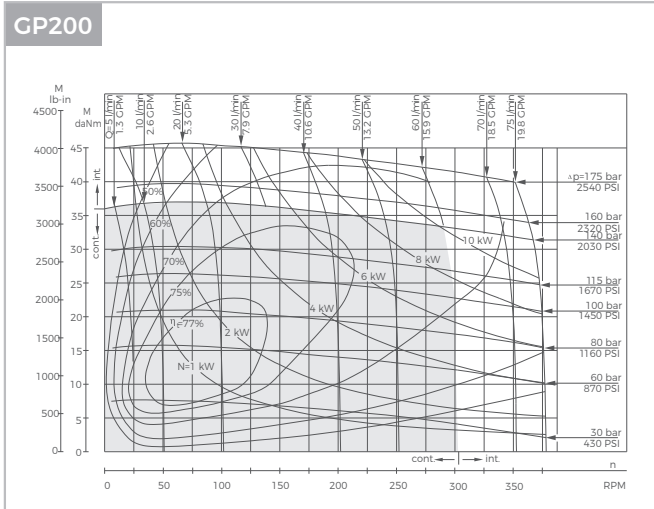
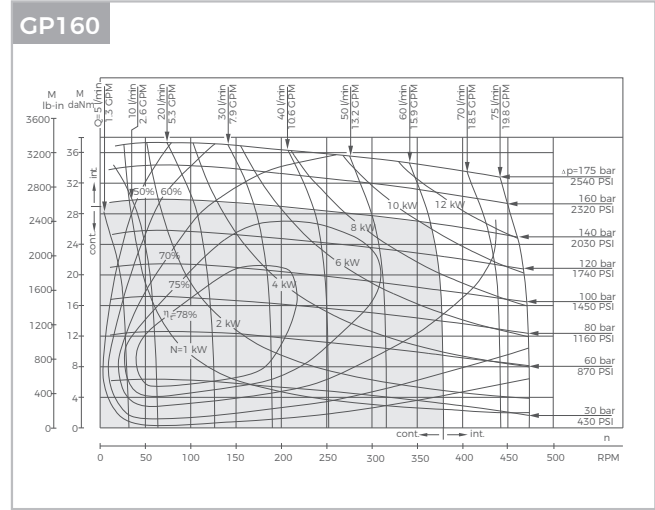
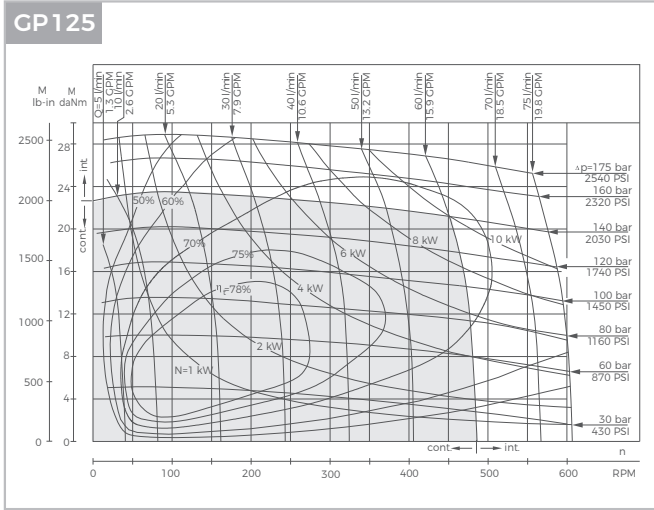

The function diagrams data is for average performance of randomly selected motors at backpressure. 5–10 bar [72.5–145 PSI] and oil with viscosity of 32 mm²/s [150 SUS] at 50°C [122°F].



Function Diagrams

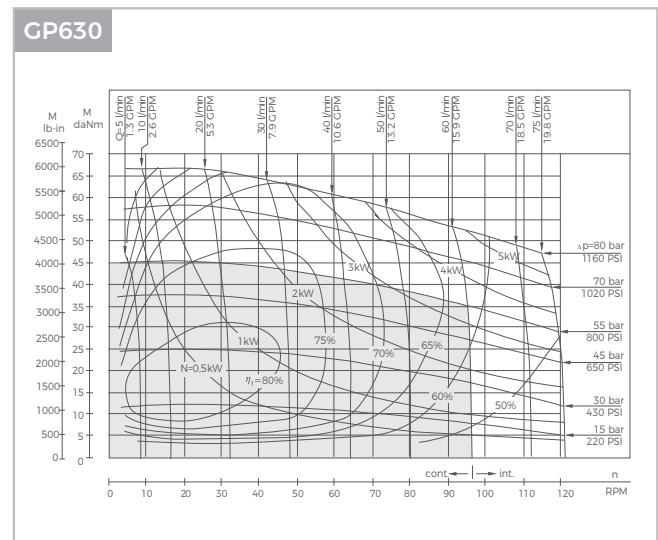
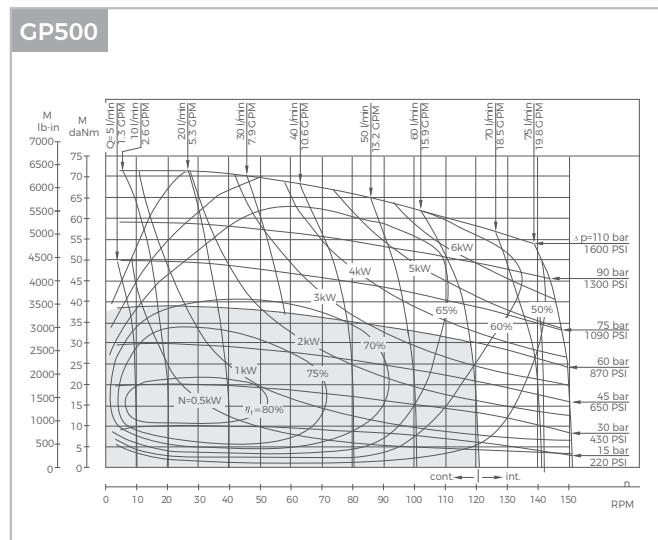
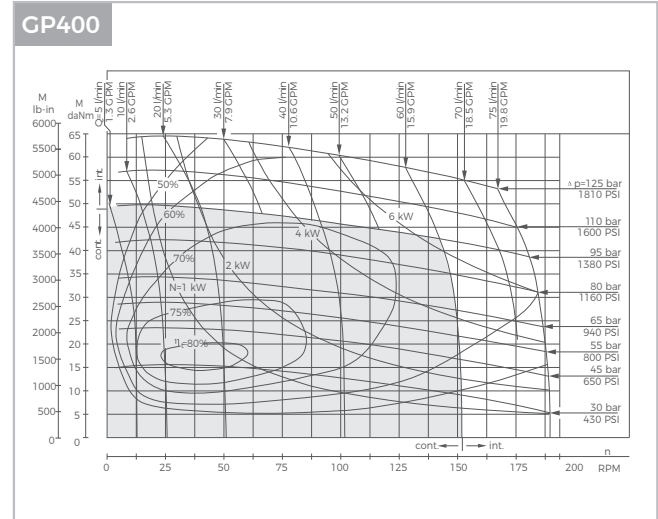
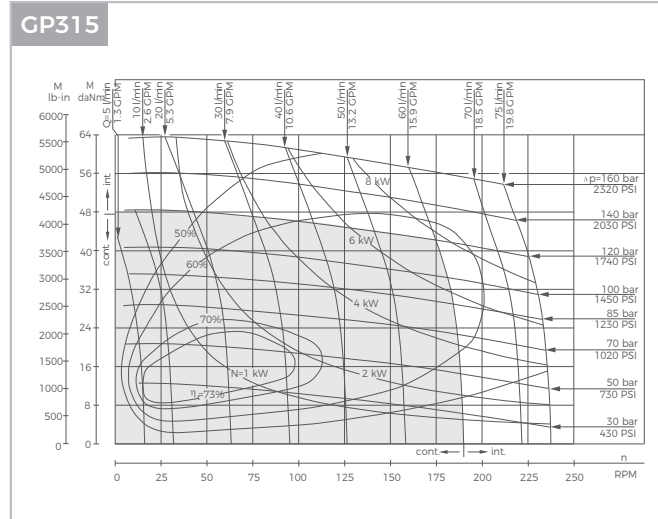

The function diagrams data is for average performance of randomly selected motors at backpressure. 5–10 bar [72.5–145 PSI] and oil with viscosity of 32 mm²/s [150 SUS] at 50°C [122°F].

GP Dimensions and Mountings

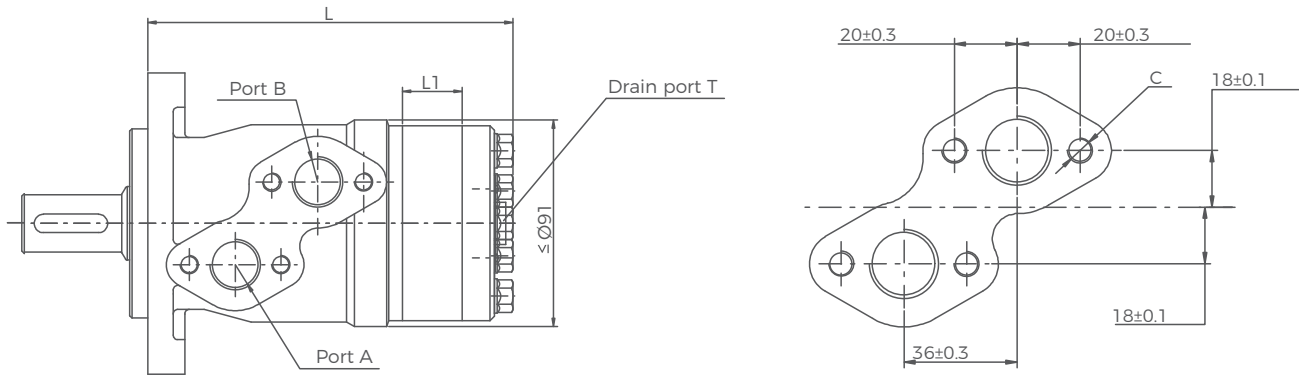

Model	L(mm)	L1(mm)
GP25	135	4.5
GP32	136	5.5
GP40	137	7
GP50	137	7
GP80	140.5	10.5
GP100	143	13
GP125	146	16
GP160	151	21
GP200	157	26
GP250	162	32
GP315	172	42
GP400	182	52
GP500	195	65
GP630	213	84

Mounting	G1 (depth)	M1 (depth)	U2 (depth)	U1 (depth)	G2 (depth)
P(A, B)	G1/2(15)	M22 x 1.5(15)	7/8-14 O-ring(17)	1/2-14NPTF(15)	PT(RC)1/2(15)
C	4-M8(13)	4-M8(13)	4-5/16-18UNC(13)	4-5/16-18UNC(13)	4-M8(13)
T	G1/4(12)	M14 x 1.5(12)	7/16-20UNF(12)	7/16-20UNF(12)	PT(RC)1/4(9.7)

GP with Manifold Dimensions and Mountings

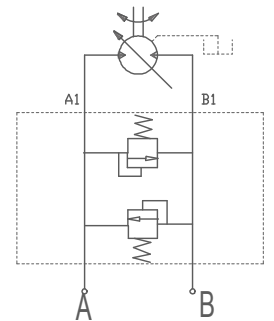
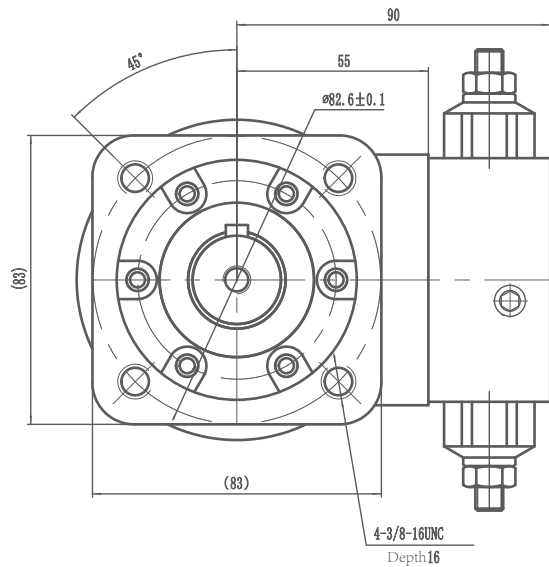
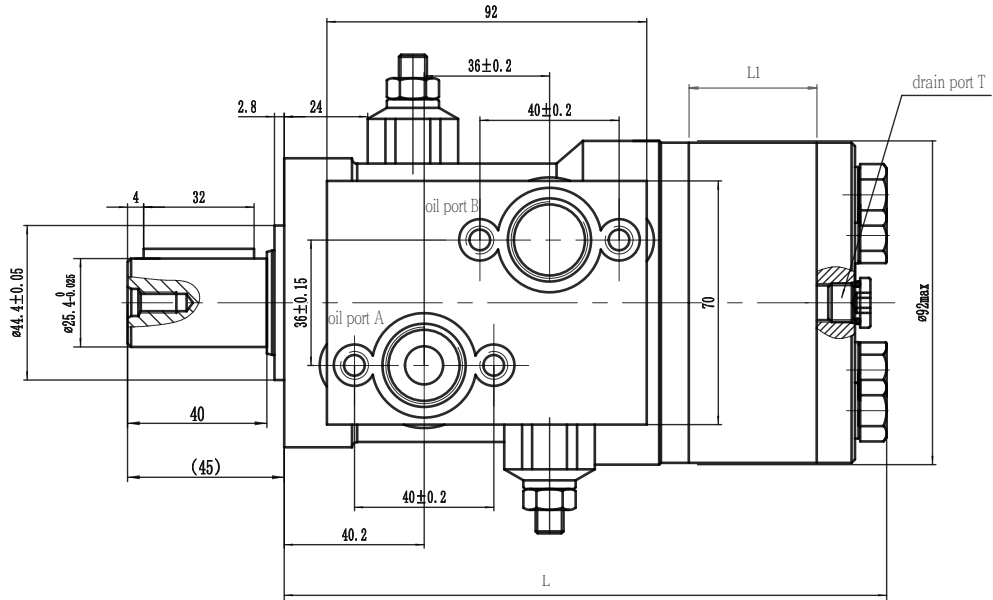

Valve setting pressure

800psi (55bar)

1300psi (90bar)

Model	L(mm)	L1(mm)
GP25	135	4.5
GP32	136	5.5
GP40	137	7
GP50	137	7
GP80	140.5	10.5
GP100	143	13
GP125	146	16
GP160	151	21
GP200	157	26
GP250	162	32
GP315	172	42
GP400	182	52
GP500	195	65
GP630	213	84

GPW Dimensions and Mountings

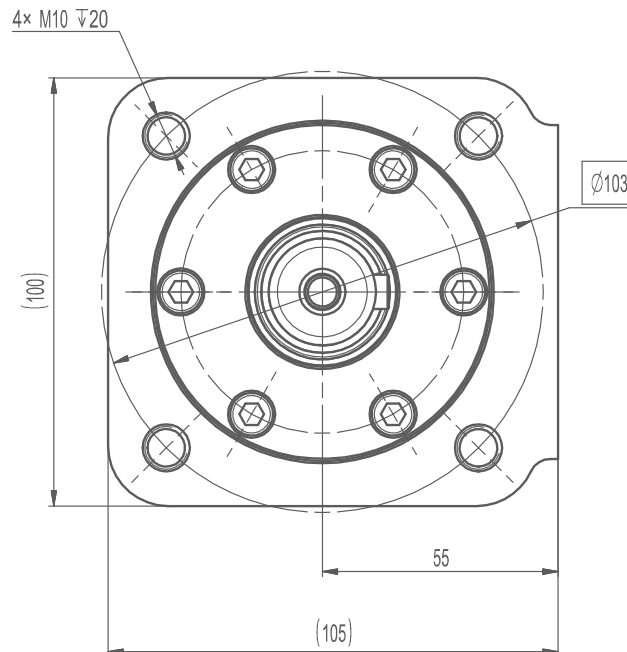
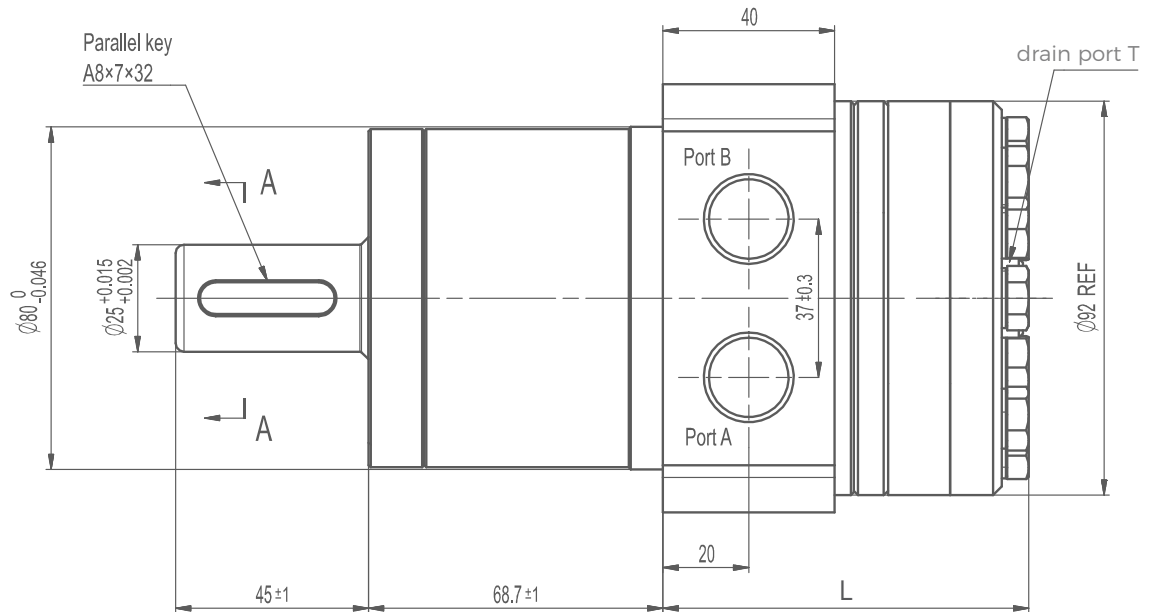

Model	L(mm)
GPW25	76
GPW32	77
GPW40	79
GPW50	82
GPW80	85
GPW100	88
GPW125	93
GPW160	99
GPW200	106
GPW250	118
GPW315	128
GPW400	134
GPW500	140
GPW630	146

Mounting	G1 (depth)	M1 (depth)	U2 (depth)	U1 (depth)	G2 (depth)
P(A, B)	G1/2(15)	M22 x 1.5(15)	7/8-14 O-ring(17)	1/2-14NPTF(15)	PT(RC)1/2(15)
C	4-M8(13)	4-M8(13)	4-5/16-18UNC(13)	4-5/16-18UNC(13)	4-M8(13)
T	G1/4(12)	M14 x 1.5(12)	7/16-20UNF(12)	7/16-20UNF(12)	PT(RC)1/4(9.7)



GP with Speed Sensor Dimensions and Mountings

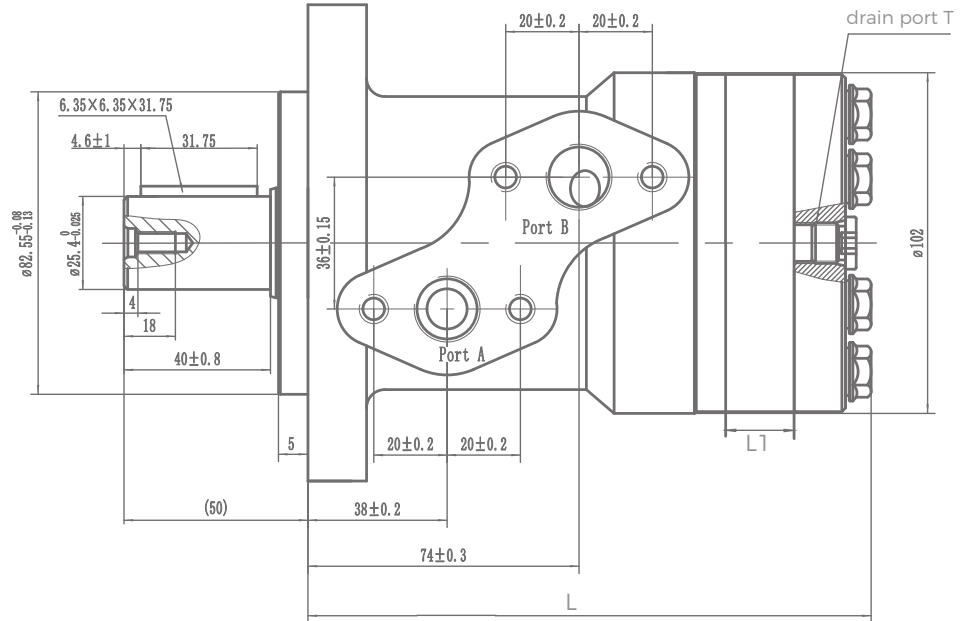

Model	L(mm)	L1(mm)
GP25	135	4.5
GP32	136	5.5
GP40	137	7
GP50	137	7
GP80	140.5	10.5
GP100	143	13
GP125	146	16
GP160	151	21
GP200	157	26
GP250	162	32
GP315	172	42
GP400	182	52
GP500	195	65
GP630	213	84

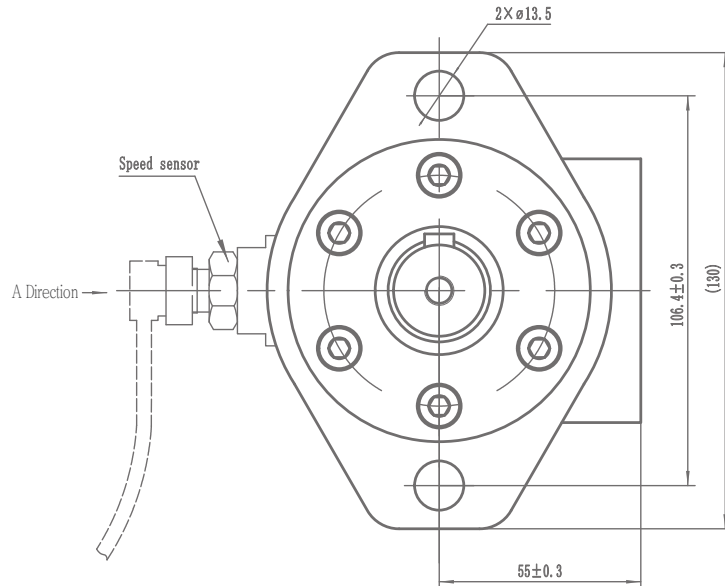

Mounting	G1 (depth)	M1 (depth)	U2 (depth)	U1 (depth)	G2 (depth)
P(A, B)	G1/2(15)	M22 x 1.5(15)	7/8-14 O-ring(17)	1/2-14NPTF(15)	PT(RC)1/2(15)
C	4-M8(13)	4-M8(13)	4-5/16-18UNC(13)	4-5/16-18UNC(13)	4-M8(13)
T	G1/4(12)	M14 x 1.5(12)	7/16-20UNF(12)	7/16-20UNF(12)	PT(RC)1/4(9.7)

GP Flange Covers Dimensions

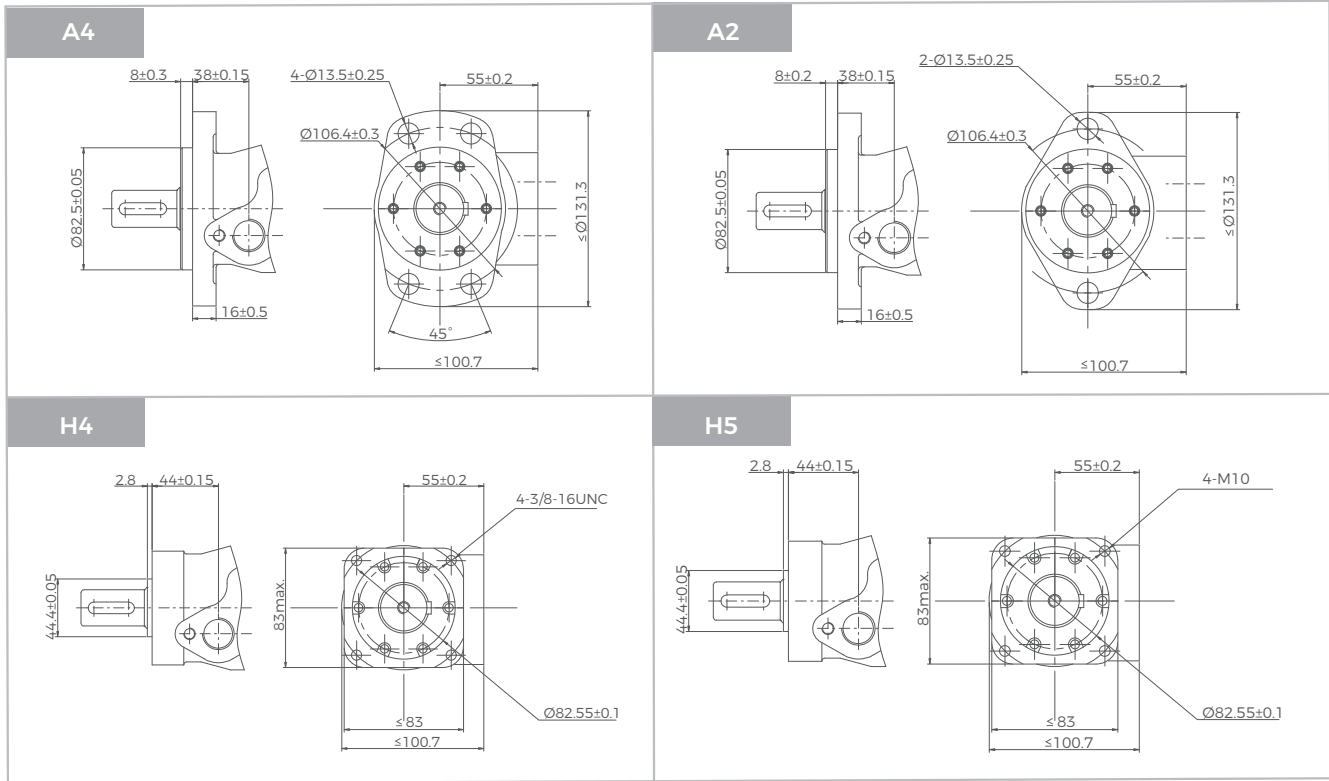

GP Shafts Dimensions

<p>S1</p> <p>Straight shaft $\text{Ø}25$ Parallel key 8 x 7 x 32</p>	<p>S4</p> <p>Straight shaft $\text{Ø}32$ Parallel key 10 x 8 x 45</p>
<p>S2</p> <p>Straight shaft $\text{Ø}25.4$ Parallel key 6.35 x 6.35 x 31.75</p>	<p>R1</p> <p>Splined shaft SAE 6B</p>
<p>R2</p> <p>Splined shaft 14 - DP 12/ 24</p>	<p>S5</p> <p>Straight shaft $\text{Ø}31.75$ Parallel key 7.96 x 7.96 x 31.75</p>

GP Shafts Dimensions

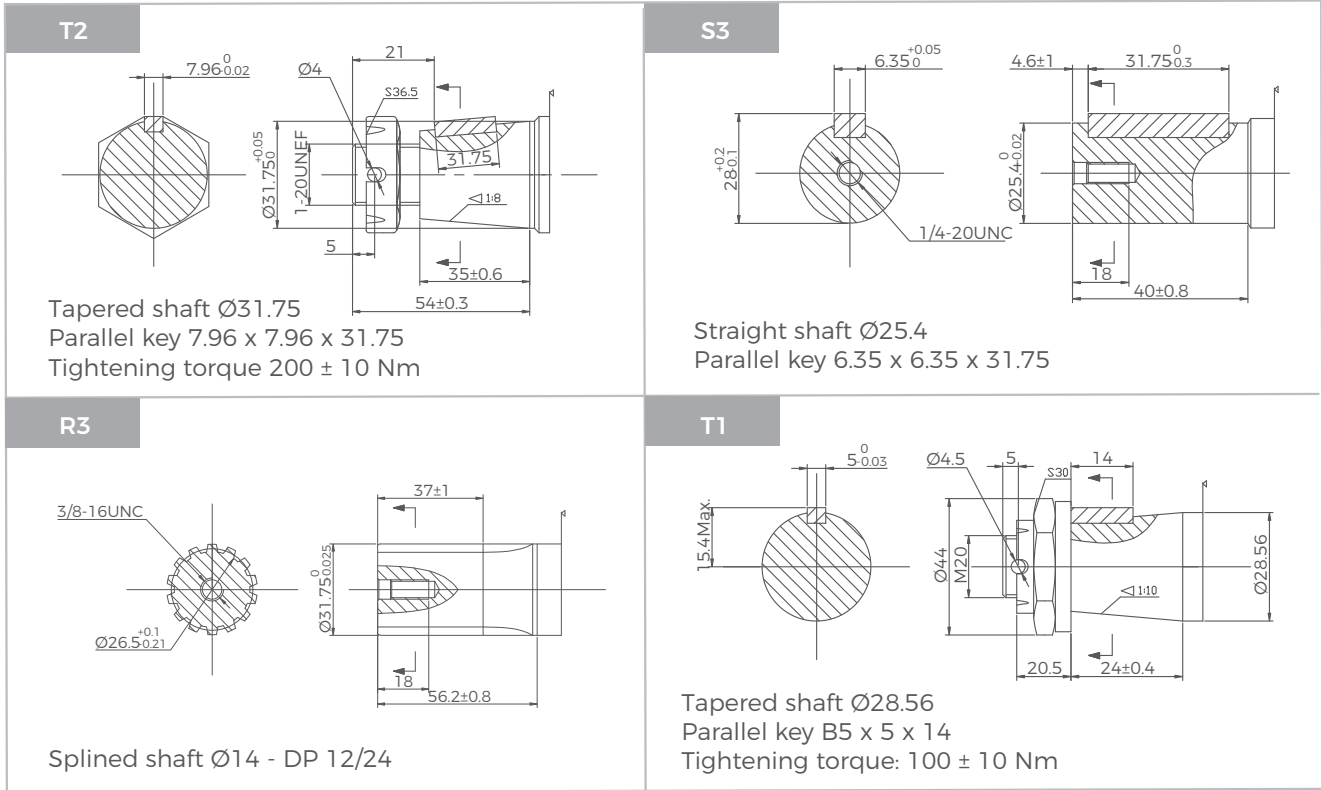

GP Series Hydraulic Motors

Permissible shaft seal pressure

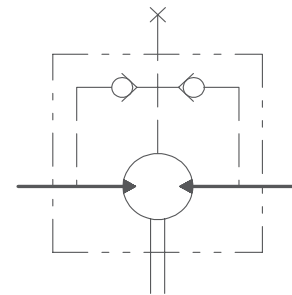
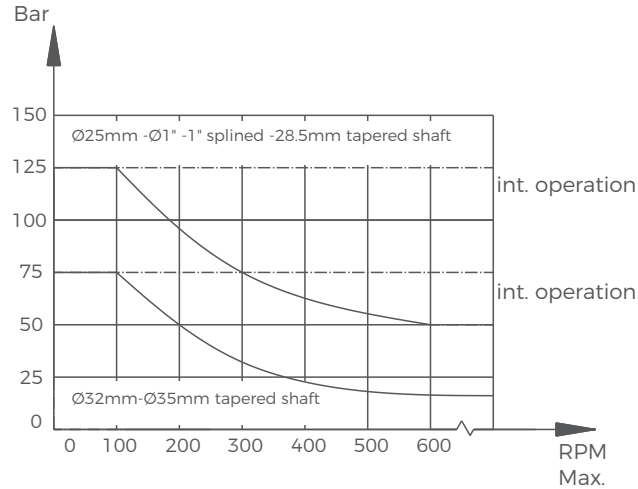

GP with standard shaft seal check valves and without use of drain connection: The pressure on the shaft seal never exceeds the pressure in the return line.

GP with standard shaft seal, check valves and with drain connection: The shaft seal pressure equals the pressure on the drain line.

Drain Port

In applications without drain line, output shaft seal exceeds a bit of the pressure in the return line. In applications using the drain line, the pressure of output shaft seal equals the pressure in drain line.

Standard direction of shaft rotation: Standard

When facing shaft end of motor, shaft to rotate:
Clockwise when port A is pressurized.
Counter-clockwise port B is pressurized.

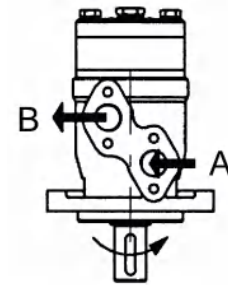

Output shaft axial and radial force

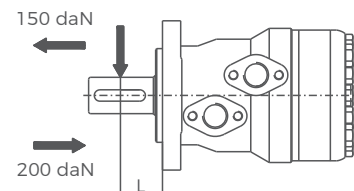
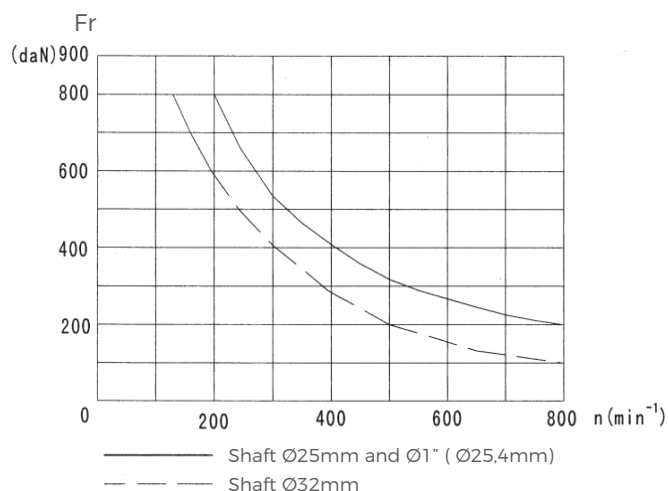

$$Fr = \frac{800}{n} * \frac{25000}{95 + L} \text{ (daN)}$$

Fr = Radial Force (daN)

L = Distance (mm)

n = Speed (rpm)

Rhomb flange L = 30mm

Square flange L = 24mm

GPH Series Hydraulic Motors

Options

- Flange connection
- Motor with needle roller bearing
- Speed sensing
- Side and bottom ports
- Shaft seal for high and low pressure
- Straight, splined and tapered shafts
- Metric and BSPP ports
- Other special features

Applications

- Conveyors
- Feeding equipment of robots and manipulators
- Metal working machines
- Textile machines
- Agricultural machines
- Food industries
- Lawn mower



General



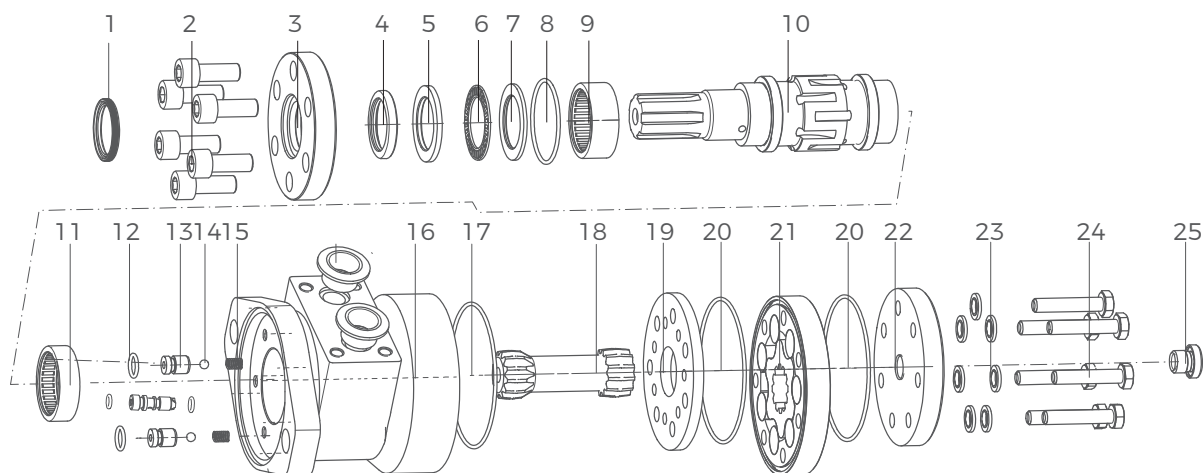







Max. Displacement	cm ³ /rev [in ³ /rev]	623,6 [38.05]
Max. Speed	RPM	1815
Max. Torque	daNm [lb-in]	cont.:188 [16650] int.:211 [18650]
Max. Output	kW [HP]	64 [85,8]
Max. Pressure Drop	bar [PSI]	cont.: 140 [2030] int.: 175 [2540]
Max. Oil Flow	lpm [GPM]	240 [63.4]
Min. Speed	RPM	10
	daN[lbs]	Pa=1500 [3300]
Pressure Fluid		Mineral based- HLP (DIN 51524) or HM (ISO 6743/4)
Temperature Range	°C [°F]	-40–140[-40–284]
Optimal Viscosity Range	mm ² /s [SUS]	20–75[98–347]
Filtration		ISO code 20/16 (Min. recommended fluid filtration of 25 microns)



1 Anti-dust ring	6 Flat bearing	11 Needle roller bearing	16 Rubber plug	21 Stator assembly
2 Bolt	7 Bearing retainer	12 O-ring seal	17 Housing	22 Rear cover
3 Front cover	8 O-ring seal	13 Check valve	18 O-ring seal	23 Combination washer
4 Shaft seal	9 Needle roller bearing	14 Steel ball	19 Transmission shaft	24 Screw
5 Bearing retainer	10 Output shaft	15 Spring	20 Spacer	25 External drain plug

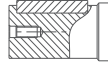

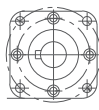
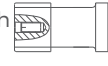
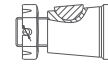
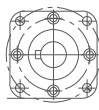
Ordering Code

GPH SERIES		DISP	FLANGE	SHAFT	PORTS	ROTATION	PAINT	FUNCTION	
CODE	DISP cm ³ /rev [in ³ /rev]	CODE	FLANGE	CODE	SHAFT	CODE	ROTATION	CODE	FUNCTION
025	25cm [1.52]	A1	2-Ø13.5,SAE Ø106.4 pilot Ø82.5×2.8 	S6	Ø25.4, woodruff key Ø25.4×6.35 	A	Standard	A	Standard
032	32 [1.95]	A3	4-Ø13.5,SAE Ø106.4 pilot Ø82.5×2.8 	R4	Ø25.4, splined tooth SAE 6B 	R	Opposite	B	Blue
040	40 [2.44]			S7	Ø25, parallel key 8×7×32 	S	No Paint		
050	49.5 [3.02]	H4	4-3/8-16UNC square, Ø82.5 pilot Ø44.4×2.8 	S8	Ø25.4, parallel key 6.35×6.35×31.75 	C	Black	S	Silver grey
080	79.2 [4.83]			SA	Ø25.4, pin hole Ø8 	B	Blue		
100	99 [6.0]			SB	Ø22.22, parallel key 6.35×6.35×25.4 	C	Black		
125	123.8 [7.55]	H5	4-M10 square, Ø82.5 pilot Ø44.4×2.8 	R5	Ø22.22, splined tooth 13-DP 16/32 	A	Standard	N	Big radial force
160	158.4 [9.66]			T3	Tapered Ø25.4 woodruff key Ø25.4×6.35 	D	No case drain		
200	198 [12.1]	H5	4-M10 square, Ø82.5 pilot Ø44.4×2.8 	SC	Ø25, parallel key 8×7×28 	F	Free running	L	Low speed
250	247.5 [15.1]			SD	Ø25, parallel key 7×7×32 	V	High Temp.		
315	316.8 [19.3]					S	Low Temp.		
400	396 [24.16]								
500	495 [30.2]								
630	623.6 [38.05]								
				CODE	PORTS				
				G7	G1/2, G14				
				U9	7/8-14UNF O-ring, 7/16-20UNF				
				UA	1/2-14NPTF, 7/16-20UNF				
				U3	3/4-16 O-ring, 7/16-20UNF				
				G8	PT(Rc) 1/2, PT(Rc) 1/4				
				D1	Ø10 O-ring, 7/16-20UNF manifold 4×5/16-18UNC				
				D2	Ø10 O-ring manifold 4×M8, G1/4				



Specifications

Type		GPH25	GPH32	GPH40	GPH50	GPH80
Displacement, cm ³ /rev [in ³ /rev]		25[1.52]	32[1.95]	40[2.44]	49.5[3.02]	79.2[4.83]
Max. Speed,	Cont.	1600	1560	1500	1210	755
RPM	Int.*	1815	1720	1750	1515	945
Max. Torque	Cont.	3,3[290]	4,3[380]	6,2[550]	9,4[835]	15,1[1340]
daNm [lb-in]	Int.*	4,7[415]	6,1[540]	8,2[730]	11,9[1050]	19,5[1725]
	Peak**	6,7[595]	8,6[760]	10,7[950]	14,3[1285]	22,4[1985]
Max. Output	Cont.	4,5[6.0]	5,8[7.8]	8,4[11.5]	10,1[13.5]	10,2[13.7]
kW [HP]	Int.*	6,1[8.2]	7,8[10.5]	11,6[15.5]	12,2[16.1]	12,5[16.8]
Max. Pressure Drop	Cont.	100[1450]	100[1450]	120[1750]	140[2030]	140[2030]
bar [PSI]	Int.*	140[2030]	140[2030]	155[2250]	175[2540]	175[2540]
	Peak**	225[3260]	225[3260]	225[3260]	225[3260]	225[3260]
Max. Oil Flow	Cont.	40[10.5]	50[13.2]	60[15.9]	60[15.9]	60[15.9]
lpm [GPM]	Int.*	45[11.9]	55[14.5]	70[18.5]	75[19.8]	75[19.8]
Max. Inlet Pressure	Cont.	175[2540]	175[2540]	175[2540]	175[2540]	175[2540]
bar [PSI]	Int.*	200[2900]	200[2900]	200[2900]	200[2900]	200[2900]
	Peak**	225[3260]	225[3260]	225[3260]	225[3260]	225[3260]
Max. Return Pressure	Cont.	175[2540]	175[2540]	175[2540]	175[2540]	175[2540]
without Drain Line	Int.*	200[2900]	200[2900]	200[2900]	200[2900]	200[2900]
bar [PSI]	Peak**	225[3260]	225[3260]	225[3260]	225[3260]	225[3260]
Max. Starting Pressure		10[145]	10[145]	10[145]	10[145]	10[145]
with Unloaded Shaft, bar [PSI]						
Min. Starting Torque	At max. press. drop Cont.	3,0[265]	4,0[355]	5,4[480]	7,8[690]	13,2[1170]
daNm [lb-in]	At max. press. drop Int.*	4,2[370]	5,6[500]	6,8[600]	10[885]	16,8[1490]
Min. Speed, RPM		20	15	10	10	10
Weight, kg [lb] For rear port + 0,450 [992]	GPH	5,6[12.3]	5,6[12.3]	5,7[12.6]	5,8[12.8]	5,9[13.2]

Specifications

Type		GPH100	GPH125	GPH160	GPH200
Displacement, cm ³ /rev [in ³ /rev]		99[6.04]	123,8[7.55]	158,4[9.66]	198[12.1]
Max. Speed,	Cont.	605	486	378	303
RPM	Int.*	755	605	472	378
Max. Torque	Cont.	19,3[1710]	23,7[2100]	31,3[2770]	36,6[3240]
daNm [lb-in]	Int.*	23,7[2100]	29,8[2640]	37,8[3345]	45,6[4035]
	Peak**	27,5[2435]	36,5[3235]	43,8[3880]	55[4870]
Max. Output	Cont.	10,5[14.1]	10,2[13.7]	10,1[13.5]	10[13.5]
kW [HP]	Int.*	12,8[17.1]	12[16.1]	12,1[16.2]	12[16.1]
Max. Pressure Drop	Cont.	140[2030]	140[2030]	140[2030]	140[2030]
bar [PSI]	Int.*	175[2540]	175[2540]	175[2540]	175[2540]
	Peak**	225[3260]	225[3260]	225[3260]	225[3260]
Max. Oil Flow	Cont.	60[15.9]	60[15.9]	60[15.9]	60[15.9]
lpm [GPM]	Int.*	75[19.8]	75[19.8]	75[19.8]	75[19.8]
Max. Inlet Pressure	Cont.	175[2540]	175[2540]	175[2540]	175[2540]
bar [PSI]	Int.*	200[2900]	200[2900]	200[2900]	200[2900]
	Peak**	225[3260]	225[3260]	225[3260]	225[3260]
Max. Return Pressure	Cont.	175[2540]	175[2540]	175[2540]	175[2540]
without Drain Line	Int.*	200[2900]	200[2900]	200[2900]	200[2900]
bar [PSI]	Peak**	225[3260]	225[3260]	225[3260]	225[3260]
Max. Starting Pressure		10[145]	9[131]	8[116]	7[100]
with Unloaded Shaft, bar [PSI]					
Min. Starting Torque	At max. press. drop Cont.	16,6[1470]	20,7[1830]	28,2[2500]	33,5[2950]
daNm [lb-in]	At max. press. drop Int.*	21[1860]	26,6[2360]	35,5[3140]	42,6[3770]
Min. Speed, RPM		10	10	10	10
Weight, kg [lb] For rear port + 0,450 [,992]	GPH	6,1[13.5]	6,2[13.7]	6,4[14.1]	6,6[14.6]



Specifications

Type		GPH250	GPH315	GPH400	GPH500	GPH630
Displacement, cm ³ /rev [in ³ /rev]		247,5[15.1]	316,8[19.3]	396[24.16]	495[30.2]	623,6[38.05]
Max. Speed, RPM	Cont.	242	190	150	120	95
	Int*	303	236	189	150	120
Max. Torque daNm [lb-in]	Cont.	38[3360]	38[3360]	36[3190]	39[3452]	44[3895]
	Int*	58,3[5160]	56[4960]	59[5240]	57[5045]	64[5665]
	Peak**	68,5[6060]	85[7505]	85,4[7560]	78[6903]	82[7257]
Max. Output kW [HP]	Cont.	7,5[10]	5,8[7.9]	4,6[6.2]	3,5[4.7]	3,3[4.4]
	Int*	12[16.1]	9[12.1]	7,8[10.5]	7,2[9.7]	5,6[7.5]
Max. Pressure Drop bar [PSI]	Cont.	110[1600]	90[1300]	70[1015]	60[870]	55[800]
	Int*	175[2540]	140[2030]	115[1665]	90[1305]	80[1160]
	Peak**	225[3260]	225[3260]	180[2610]	130[1885]	110[1740]
Max. Oil Flow lpm [GPM]	Cont.	60[15.9]	60[15.9]	60[15.9]	60[15.9]	60[15.9]
	Int*	75[19.8]	75[19.8]	75[19.8]	75[19.8]	75[19.8]
Max. Inlet Pressure bar [PSI]	Cont.	175[2540]	175[2540]	175[2540]	140[2030]	140[2030]
	Int*	200[2900]	200[2900]	200[2900]	175[2540]	175[2540]
	Peak**	225[3260]	225[3260]	225[3260]	225[3260]	225[3260]
Max. Return Pressure without Drain Line bar [PSI]	Cont.	175[2540]	175[2540]	175[2540]	140[2030]	140[2030]
	Int*	200[2900]	200[2900]	200[2900]	175[2540]	175[2540]
	Peak**	225[3260]	225[3260]	225[3260]	225[3260]	225[3260]
Max. Starting Pressure with Unloaded Shaft, bar [PSI]		6[87]	5[73]	5[73]	5[73]	5[73]
Min. Starting Torque daNm [lb-in]	At max. press. drop Cont.	33,6[2970]	34,4[3045]	34,5[3050]	36[3180]	41,5[3670]
	At max. press. drop Int*	54,2[4795]	61,9[5480]	60,8[5390]	54[4780]	62[5480]
Min. Speed, RPM		10	10	10	10	10
Weight, kg [lb] For rear port + 0,450 [.992]		GPH 6,8[15]	7,1[15.6]	7,6[16.8]	8,9[20]	9,5[21.4]



Function Diagrams

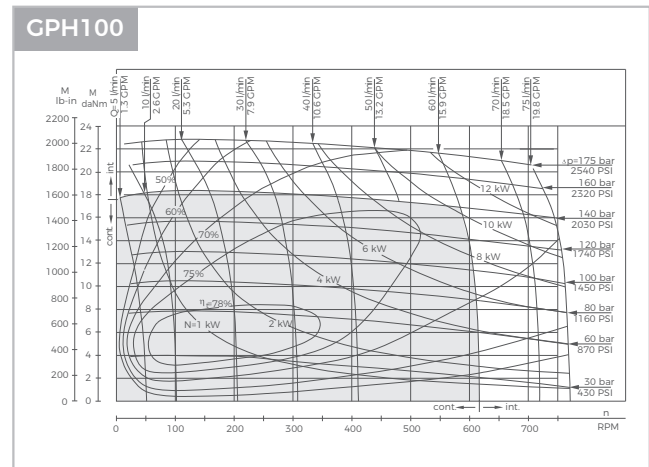
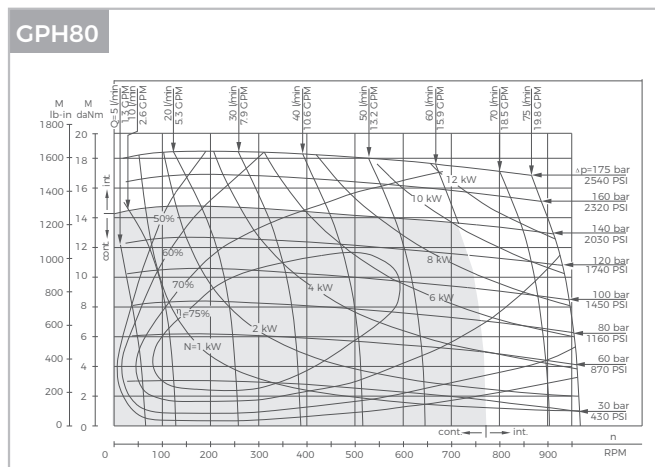
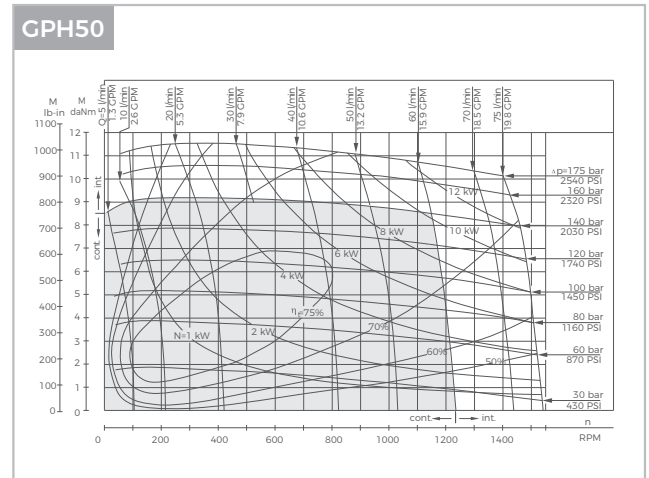
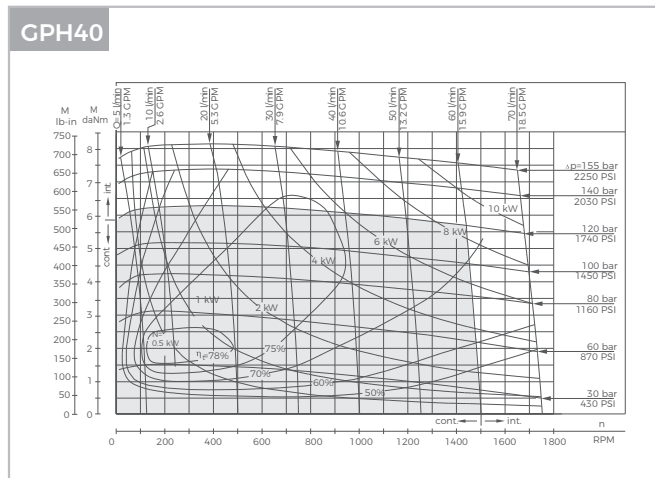
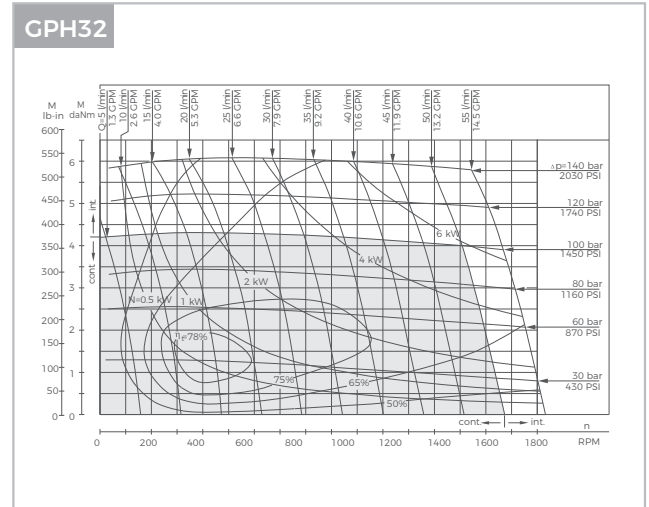
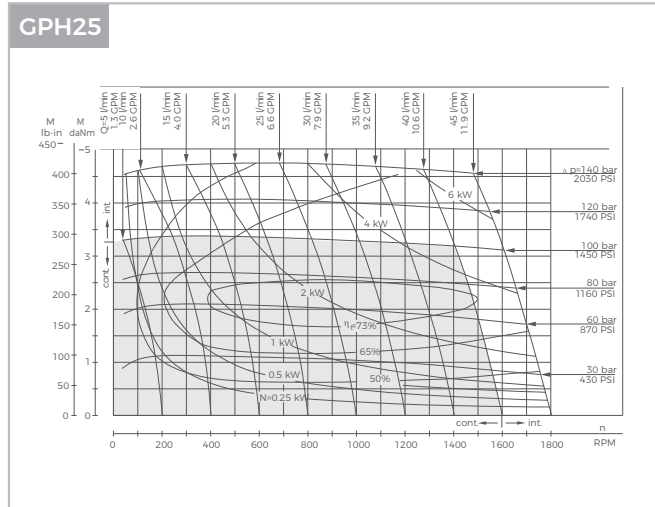

The function diagrams data is for average performance of randomly selected motors at backpressure. 5–10 bar [72.5–145 PSI] and oil with viscosity of 32 mm²/s [150 SUS] at 50°C [122°F].

Function Diagrams

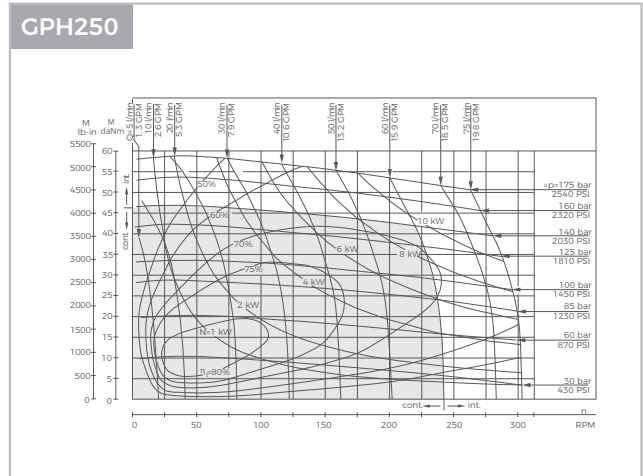
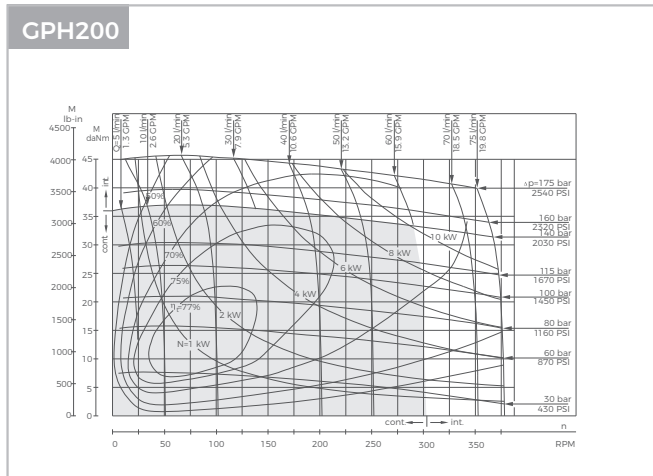
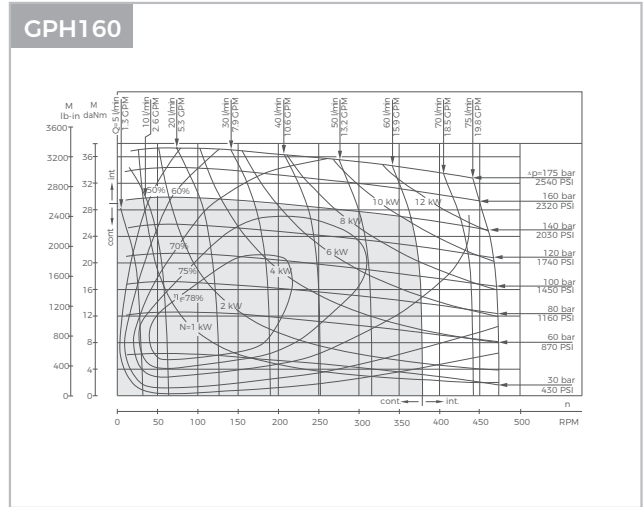
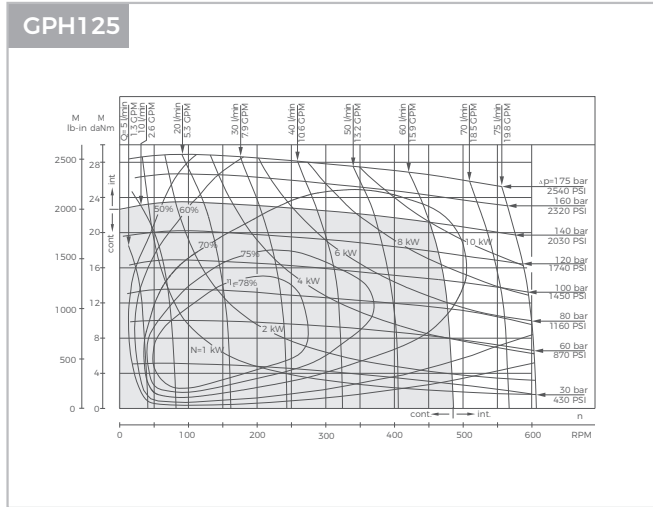

The function diagrams data is for average performance of randomly selected motors at backpressure. 5–10 bar [72.5–145 PSI] and oil with viscosity of 32 mm²/s [150 SUS] at 50°C [122°F].



Function Diagrams

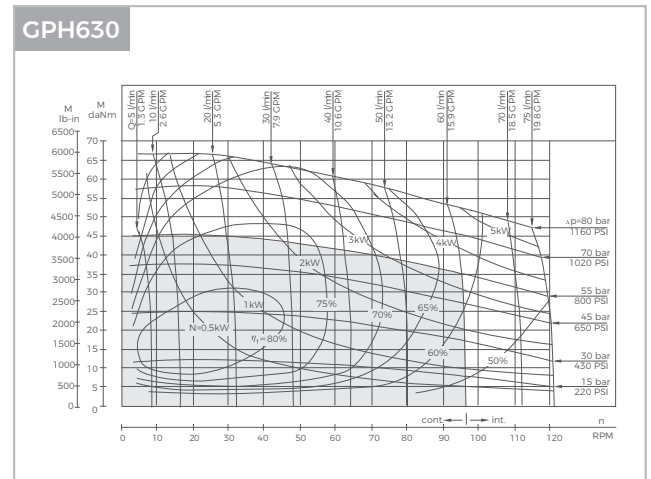
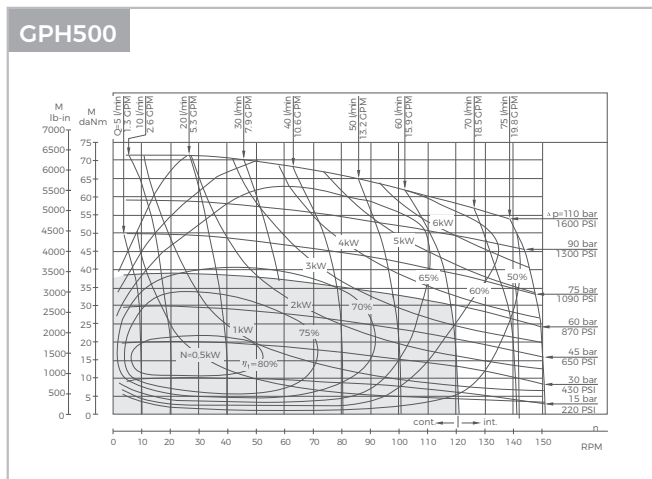
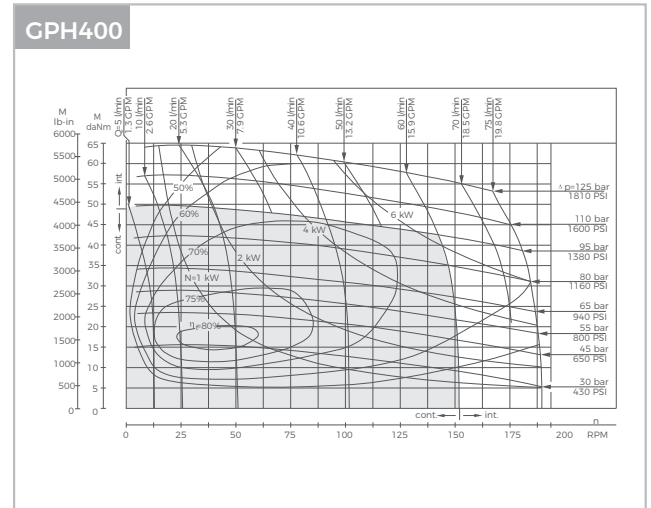
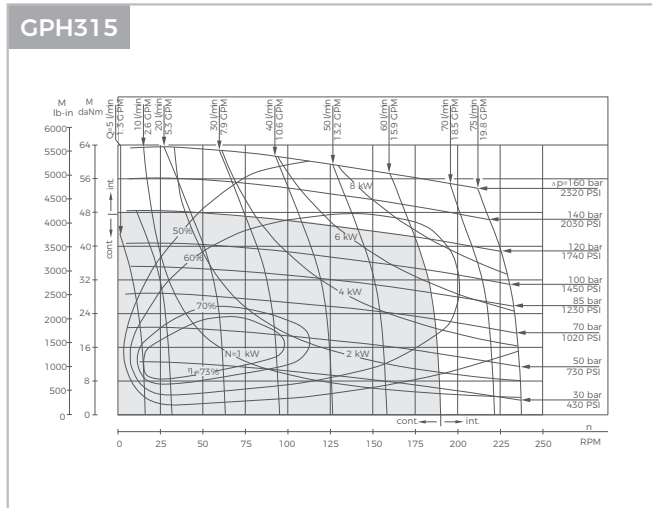

The function diagrams data is for average performance of randomly selected motors at backpressure. 5–10 bar [72.5–145 PSI] and oil with viscosity of 32 mm²/s [150 SUS] at 50°C [122°F].

GPH Dimensions and Mountings

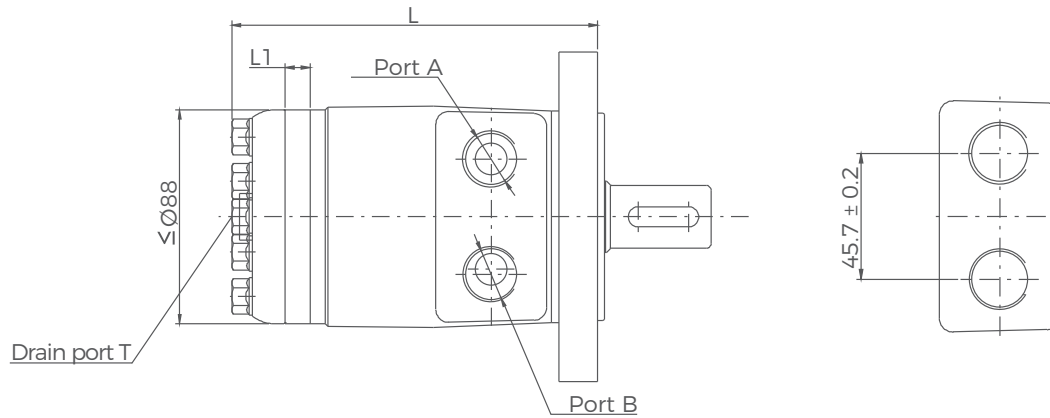

Model	L(mm)	L(mm)
GPH40	136	5.5
GPH50	137	7
GPH80	144.5	10.5
GPH100	147	13
GPH125	150	16
GPH160	155	21
GPH200	160	26
GPH250	166	32
GPH315	176	42
GPH400	186	52
GPH500	199	65
GPH630	203	84

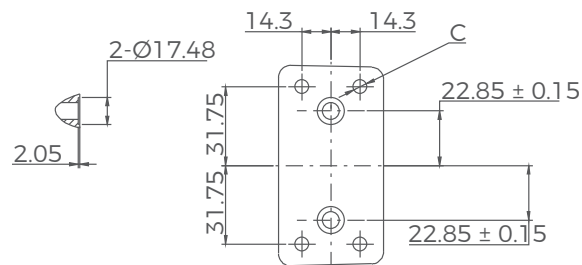

Mounting	G7 (depth)	U9 (depth)	UA (depth)	U3 (depth)	G8 (depth)	D1 (depth)	D2 (depth)
P(A, B)	G1/2(15)	7/8-14 O-ring(17)	1/2-14NPTF(15)	3/4-16 O-ring(15)	PT(RC)1/2(15)	Ø10	Ø10
T	G1/4(12)	7/16-20UNF(12)	7/16-20UNF(12)	7/16-20UNF(12)	PT(RC)1/4(9.7)	7/16-20UNF(12)	G1/4(12)
C	—	—	—	—	—	4-5/16-18UNC(13)	4-M8(13)

GPH Flange Covers Dimensions

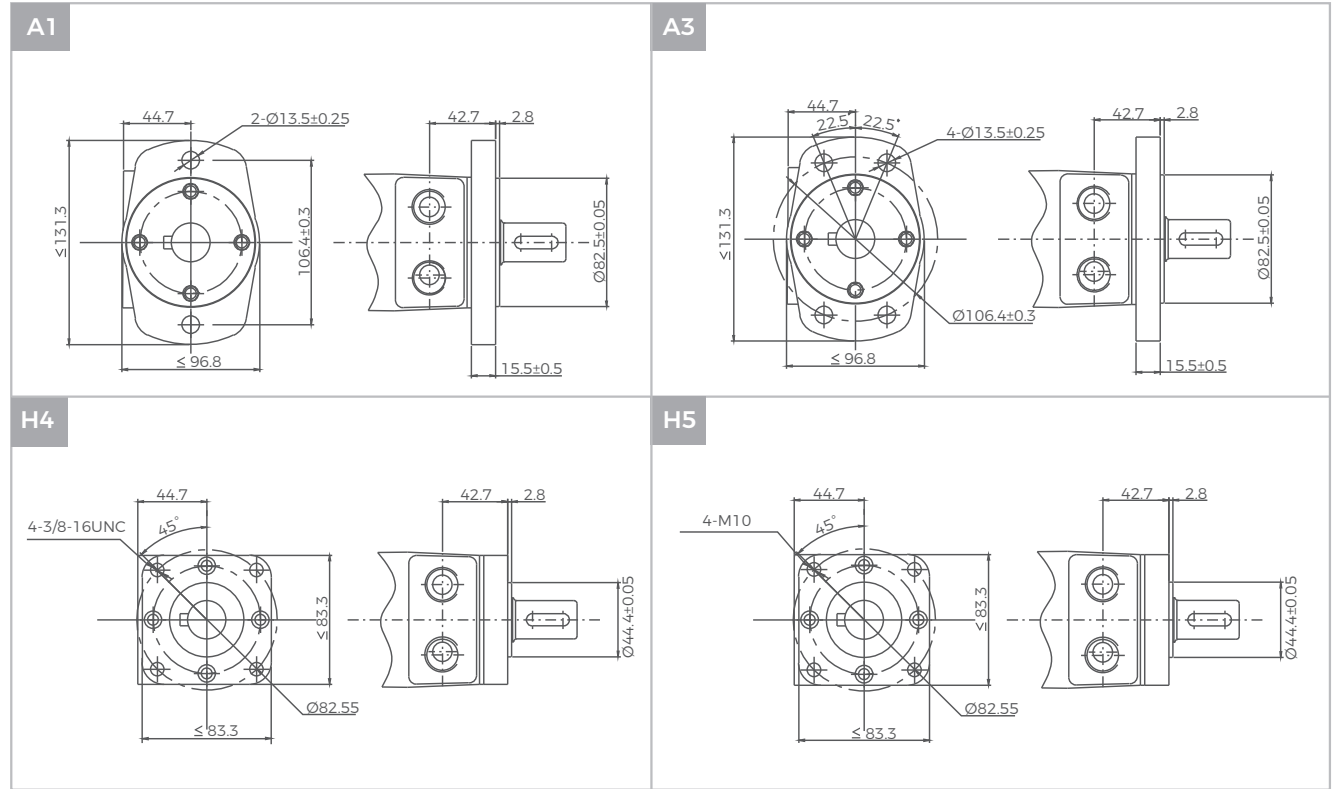

GPH Shafts Dimensions

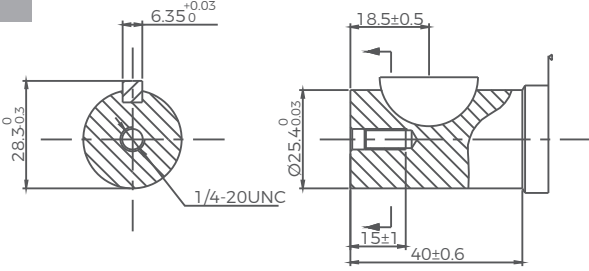
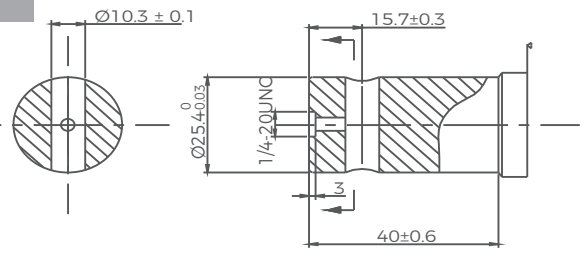
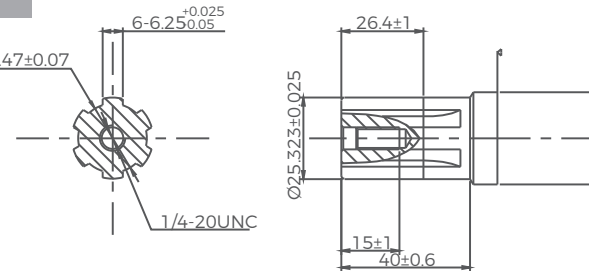
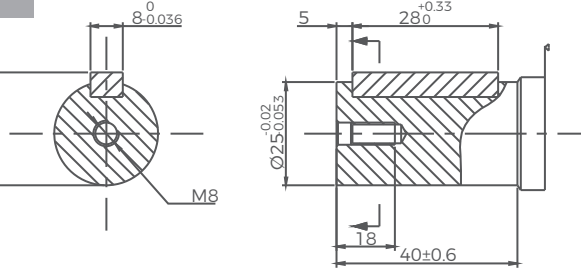
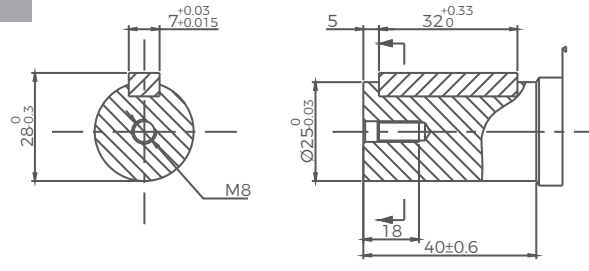
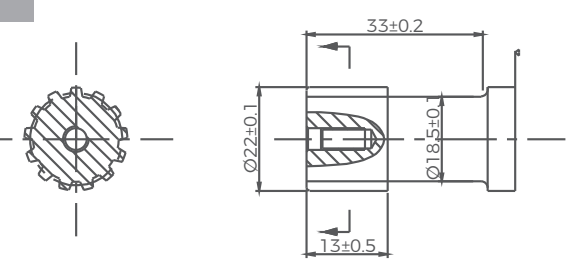
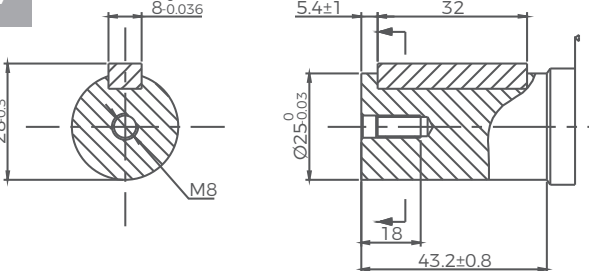
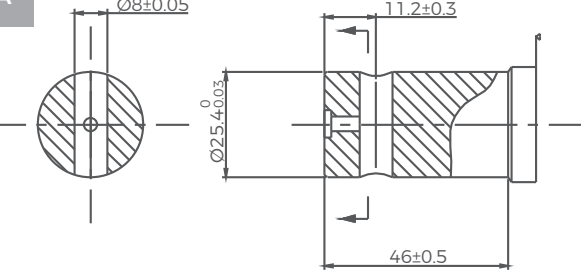
<p>S6</p>  <p>Straight shaft $\text{Ø}25.4$ Woodruff key $\text{Ø}25.4 \times 6.35$</p>	<p>S9</p>  <p>Straight shaft $\text{Ø}25.4$ Pin hole $\text{Ø}10.3$</p>
<p>R4</p>  <p>Splined shaft SAE 6B</p>	<p>SC</p>  <p>Straight shaft $\text{Ø}25$ Parallel key $8 \times 7 \times 28$</p>
<p>SD</p>  <p>Straight shaft $\text{Ø}25$ Parallel key $7 \times 7 \times 32$</p>	<p>R5</p>  <p>Splined shaft 13-DP 16/32</p>
<p>S7</p>  <p>Straight shaft $\text{Ø}25$ Parallel key $8 \times 7 \times 32$</p>	<p>SA</p>  <p>Straight shaft $\text{Ø}25.4$ Pin hole $\text{Ø}8$</p>



GPB Shafts Dimensions

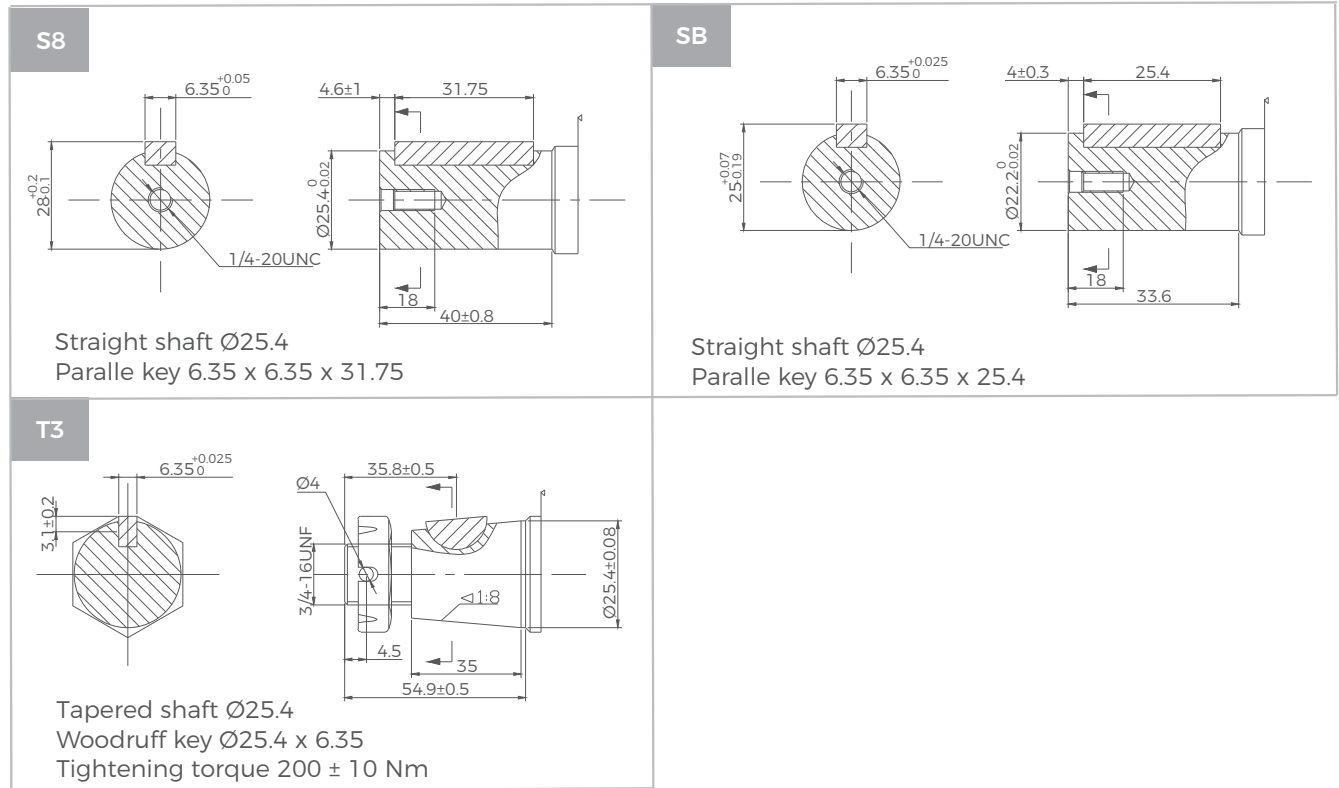

GPH Series Hydraulic Motors

Permissible shaft seal pressure

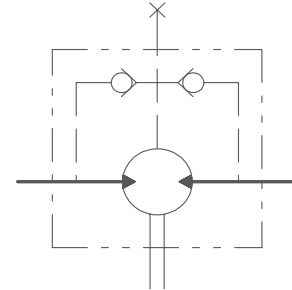
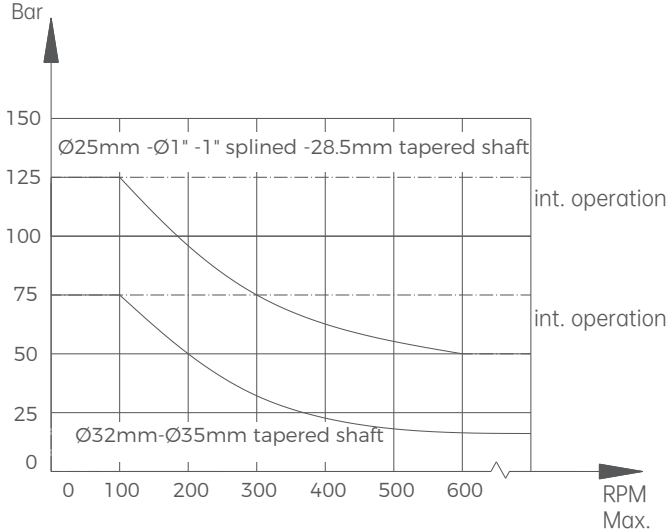

GPH with standard shaft seal check valves and without use of drain connection: The pressure on the shaft seal never exceeds the pressure in the return line.
 GPH with standard shaft seal, check valves and with drain connection: The shaft seal pressure equals the pressure on the drain line.

Drain Port

In applications without drain line, output shaft seal exceeds a bit of the pressure in the return line. In applications using the drain line, the pressure of output shaft seal equals the pressure in drain line.

Standard direction of shaft rotation: Standard

When facing shaft end of motor, shaft to rotate:
 Clockwise. When port A is pressurized.
 Counter-clockwise port B is pressurized.

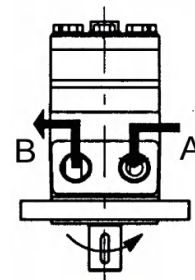

Output shaft axial and radial force

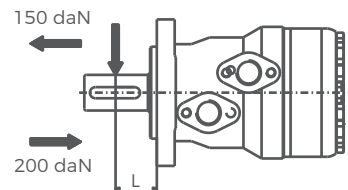
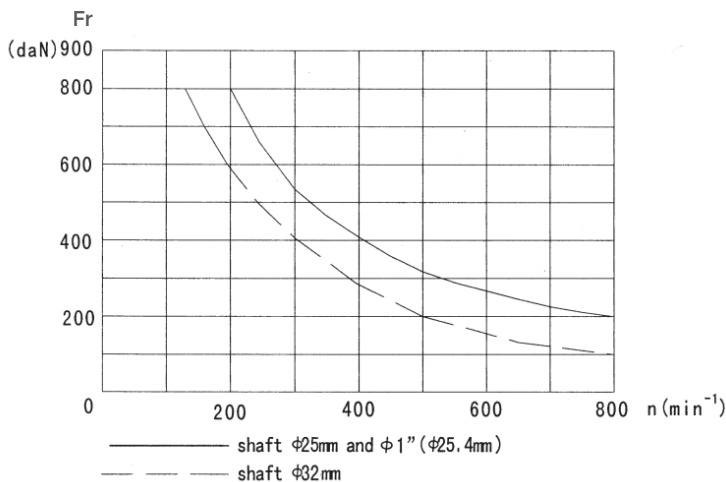

$$Fr = \frac{800}{n} * \frac{25000}{95 + L} \text{ (daN)}$$

Fr = Radial Force (daN)

L = Distance (mm)

n = Speed (rpm)

Rhomb-flange L = 30mm

Square-flange L = 24mm



GR Series Hydraulic Motors

Options

- Flange connection
- Motor with needle bearing
- Side and rear ports
- Straight, splined and tapered shafts
- Shaft seal for high and low pressure
- Metric and BSPP ports
- Speed sensing
- Other special features

Applications

- Conveyors
- Feeding equipment of robots and manipulators
- Metal working machines
- Textile machines
- Agricultural machines
- Food industries
- Lawn mower





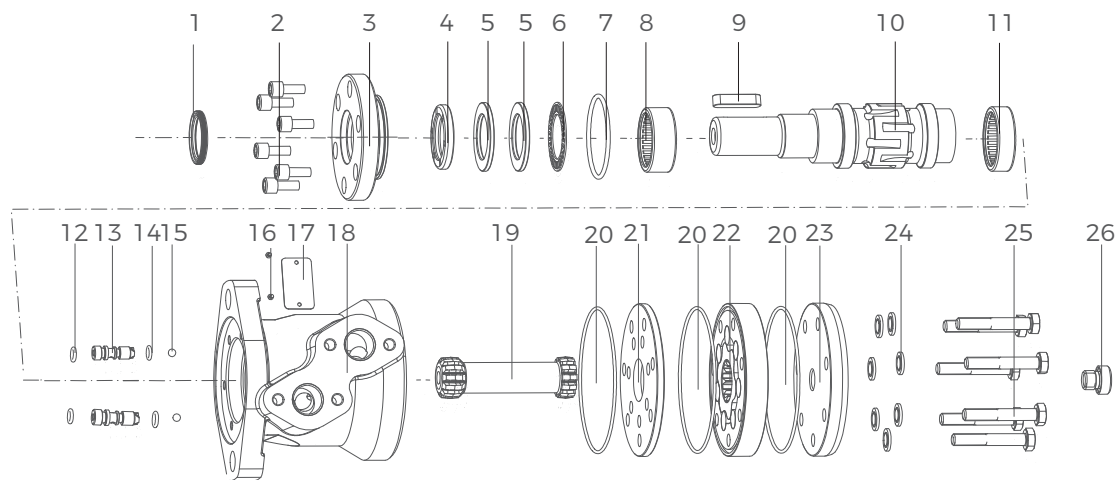

General

Max. Displacement	cm ³ /rev [in ³ /rev]	397 [24.4]
Max. Speed	RPM	970
Max. Torque	daNm [lb-in]	cont.:61 [5400] int.:69 [6100]
Max. Output	kW [HP]	15 [20.1]
Max. Pressure Drop	bar [PSI]	cont.:175 [2540] int.:200 [2900]
Max. Oil Flow	lpm [GPM]	75 [20]
Min. Speed	RPM	10
Pressure fluid		Mineral based- HLP (DIN 51524) or HM (ISO 6743/4)
Temperature Range	°C [°F]	-40-140[-104-284]
Optimal Viscosity range	mm ² /s [SUS]	20-75[98-347]
Filtration		ISO code: 20/16 (Min. recommended fluid filtration of 25 microns)

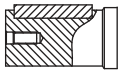
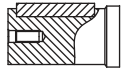
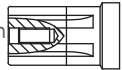
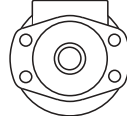
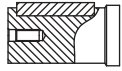
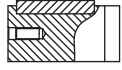

- | | | | | |
|---------------------------|-------------------------|--------------------------|-----------------------|---------------------|
| 1 Anti-dust ring | 6 Needle roller bearing | 11 Needle roller bearing | 16 Nameplate rivet | 21 Spacer |
| 2 Bolt | 7 O-ring seal | 12 O-ring seal | 17 Nameplate | 22 Rotor and stator |
| 3 Front cover | 8 Needle roller bearing | 13 Check valve | 18 Housing | 23 Rear cover |
| 4 Pressure resistant seal | 9 Parallel Key | 14 O-ring seal | 19 Transmission shaft | 24 Washer |
| 5 Retainer | 10 Output shaft | 15 Steel ball | 20 O-ring seal | 25 Bolt |
| | | | | 26 Drain plug |

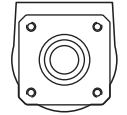
Ordering Code

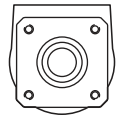
GR SERIES		DISP		FLANGE		SHAFT		PORTS		ROTATION		PAINT		FUNCTION	
CODE	DISP cm ³ /rev [in ³ /rev]	CODE	FLANGE	CODE	SHAFT	CODE	PORTS	CODE	ROTATION	CODE	PAINT	CODE	FUNCTION		
50	51.5 [3.14]	A2	2-Ø13.5 SAE A, Ø106.4 pilot Ø82.5×8 	S1	Ø25, parallel key 8×7×32 	A	Standard	G1	G1/2, G1/4 manifold 4×M8	R	Opposite	A	No Paint		
80	80.3 [4.90]			S2	Ø25.4, parallel key 6.35×6.35×31.75 	B	Blue								
100	99.8 [6.09]			R1	Ø25.4, splined tooth SAE 6B 	C	Black								
125	125.7 [7.67]	A4	4-Ø13.5 SAE A, Ø106.4 pilot Ø82.5×8 	S3	Short: Ø25.4, parallel key 6.35×6.35×31.75 	S	Silver grey	U2	7/8-14UNF O-ring, 7/16-20UNF manifold 4×5/16-18UNC						
160	159.6 [9.74]			S4	Ø32, parallel key 10×8×45 	L	Low speed								
200	199.8 [12.19]			R2	Ø31.75, splined tooth 14-DP 12/24 	V	High temp.								
250	250.1 [15.26]	H4	4-3/8-16 square, Ø82.5 pilot Ø44.4×2.8 	S5	Ø31.75, parallel key 7.96×7.96×31.75 	S	Low temp.	U1	1/2-14NPTF, 7/16-20UNF manifold 4×5/16-18UNC						
315	315.7 [19.26]			T1	Tapered Ø28.56, 1:10 parallel key B5×5×14 	G2	PT(Rc)1/2, PT(Rc)1/4 manifold 4×M8								
400	397 [24.4]			H5	4-M10 square, pilot Ø44.4×2.8 										



Specifications

Type		GR50	GR80	GR100	GR125	GR160
Displacement, cm ³ /rev [in ³ /rev]		51,5[3.14]	80,3[4.90]	99,8[6.09]	125,7[7.67]	159,6[9.74]
Max. Speed, RPM	Cont.	775	750	600	457	375
	Int.*	970	940	750	600	470
Max. Torque daNm [lb-in]	Cont.	10[900]	20[1770]	24[2125]	30[2655]	39[3450]
	Int.*	13[1150]	22[1947]	28[2480]	34[3010]	43[3805]
	Peak**	17[1505]	27[2390]	32[2832]	37[3275]	46[4070]
Max. Output kW [HP]	Cont.	7[9.5]	12,5[17]	13[17.4]	12,5[16.8]	11,5[15.4]
	Int.*	8,5[11.9]	15[20.1]	15[20.1]	14,5[19.5]	14[18.8]
Max. Pressure Drop bar [PSI]	Cont.	140[2030]	175[2540]	175[2540]	175[2540]	175[2540]
	Int.*	175[2540]	200[2900]	200[2900]	200[2900]	200[2900]
	Peak**	225[3260]	225[3260]	225[3260]	225[3260]	225[3260]
Max. Oil Flow lpm [GPM]	Cont.	40[10.5]	60[15.8]	60[15.8]	60[15.8]	60[15.8]
	Int.*	50[13.2]	75[19.8]	75[19.8]	75[19.8]	75[19.8]
Max. Inlet Pressure bar [PSI]	Cont.	175[2540]	175[2540]	175[2540]	175[2540]	175[2540]
	Int.*	200[2900]	200[2900]	200[2900]	200[2900]	200[2900]
	Peak**	225[3260]	225[3260]	225[3260]	225[3260]	225[3260]
Max. Return Pressure without Drain Line bar [PSI]	Cont.	175[2540]	175[2540]	175[2540]	175[2540]	175[2540]
	Int.*	200[2900]	200[2900]	200[2900]	200[2900]	200[2900]
	Peak**	225[3260]	225[3260]	225[3260]	225[3260]	225[3260]
Max. Starting Pressure with Unloaded Shaft, bar [PSI]		10[145]	10[145]	10[145]	9[130]	7[102]
Min. Starting Torque daNm [lb-in]	At max. press. drop Cont.	8[710]	15[1330]	20[1770]	25[2215]	32[2832]
	At max. press. drop Int.*	10[85]	17[1505]	23[2035]	28[2480]	37[3275]
Min. Speed, RPM		10	10	10	10	10
Weight, kg [lb] For rear port + 0,650 [1.433]		GR 6,8[15]	6,9[15.2]	7,2[15.9]	7,3[16.1]	7,5[15.2]



Specifications

Type		GR200	GR250	GR315	GR400
Displacement, cm ³ /rev [in ³ /rev]		199,8[12.19]	250,13[15.26]	315,7[19.26]	397[24.4]
Max. Speed,	Cont.	300	240	194	150
RPM	Int.*	375	300	240	190
Max. Torque	Cont.	45[4000]	54[4780]	55[4870]	61[5400]
daNm [lb-in]	Int.*	50[4425]	61[5400]	69[6110]	69[6110]
	Peak**	56[4960]	71[6280]	84[7435]	87[7770]
Max. Output	Cont.	11[4.8]	10[20.13.4]	9[12]	7.8[10.5]
kW [HP]	Int.*	13[17.4]	12[16.1]	10[13.4]	10.6[14.2]
Max. Pressure Drop	Cont.	175[2540]	175[2540]	135[1960]	110[1600]
bar [PSI]	Int.*	200[2900]	200[2900]	200[2900]	200[2900]
	Peak**	225[3260]	225[3260]	225[3260]	225[3260]
Max. Oil Flow	Cont.	60[15.8]	60[15.8]	60[15.8]	60[15.8]
lpm [GPM]	Int.*	75[19.8]	75[19.8]	75[19.8]	75[19.8]
Max. Inlet Pressure	Cont.	175[2540]	175[2540]	175[2540]	175[2540]
bar [PSI]	Int.*	200[2900]	200[2900]	200[2900]	200[2900]
	Peak**	225[3260]	225[3260]	225[3260]	225[3260]
Max. Return Pressure	Cont.	175[2540]	175[2540]	175[2540]	175[2540]
without Drain Line	Int.*	200[2900]	200[2900]	200[2900]	200[2900]
bar [PSI]	Peak**	225[3260]	225[3260]	225[3260]	225[3260]
Max. Starting Pressure					
with Unloaded Shaft, bar [PSI]		5[73]	4[58]	3[44]	3[44]
Min. Starting Torque	At max. press. drop Cont.	41[3630]	50[4425]	50[4425]	50[4425]
daNm [lb-in]	At max. press. drop Int.*	46[4070]	55[4870]	66[5840]	61[5400]
Min. Speed, RPM		10	10	10	10
Weight, kg [lb] For					
rear port + 0,650 [1.433]	GR	8,1[18.9]	8,5[18.7]	9,2[20.3]	9,9[21.8]



Function Diagrams

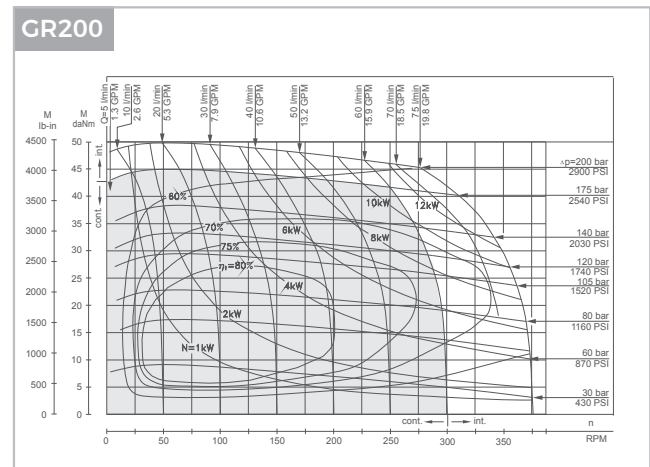
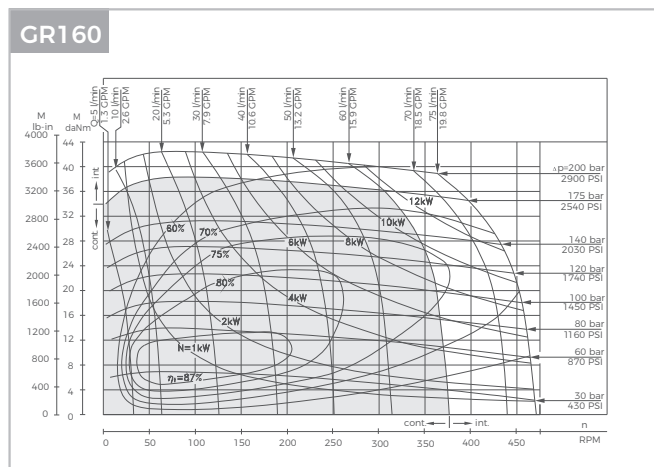
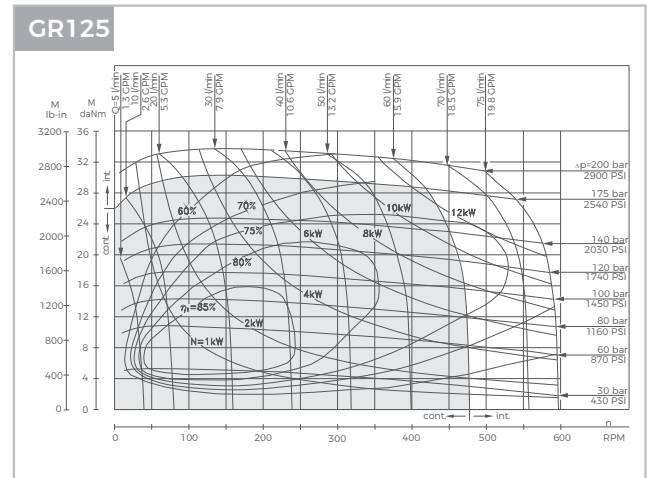
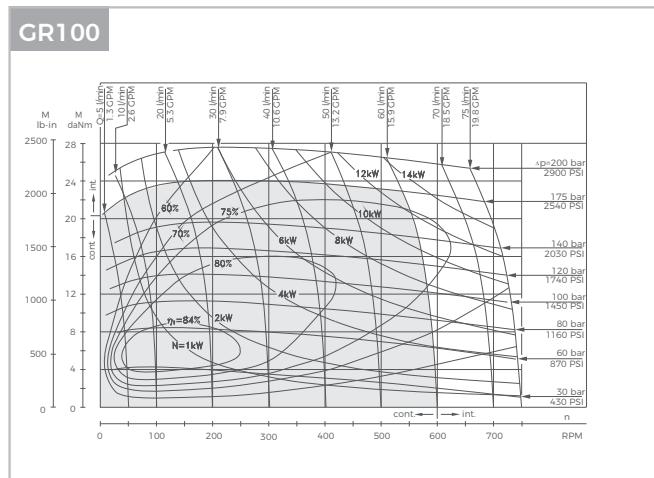
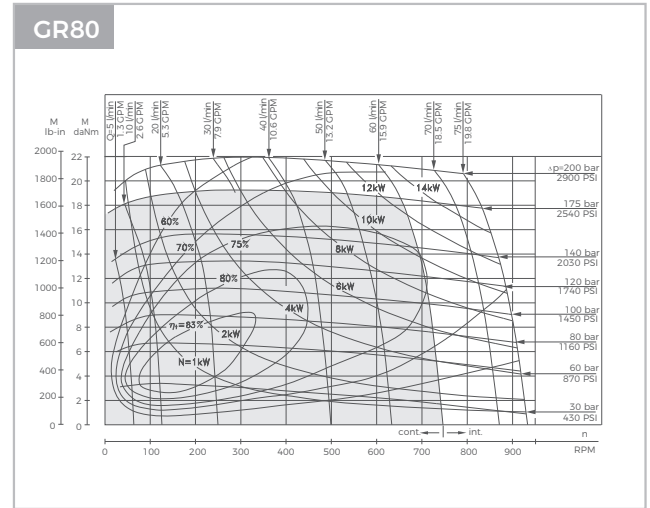
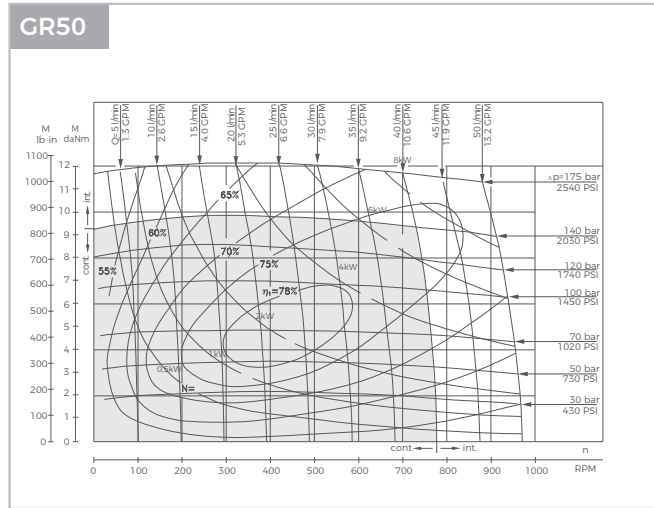

The function diagrams data is for average performance of randomly selected motors at backpressure. 5–10 bar [72.5–145 PSI] and oil with viscosity of 32 mm²/s [150 SUS] at 50°C [122°F].

Function Diagrams

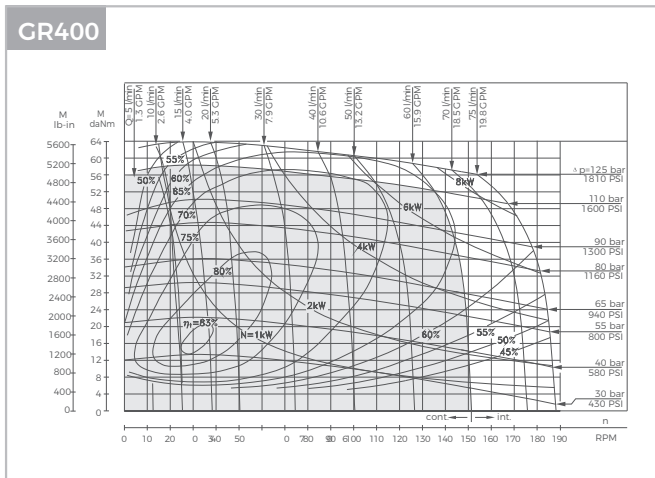
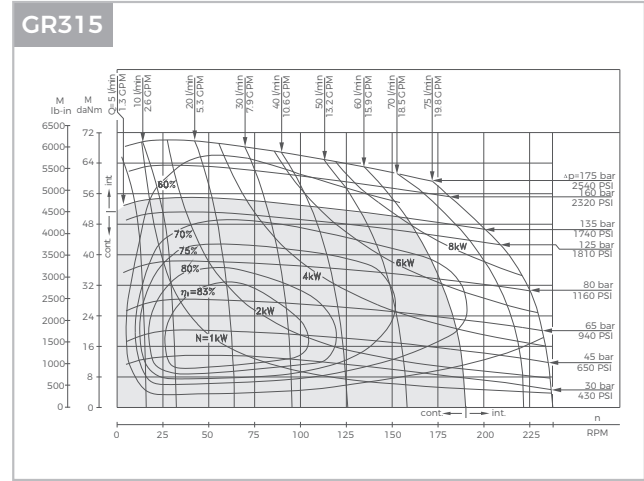
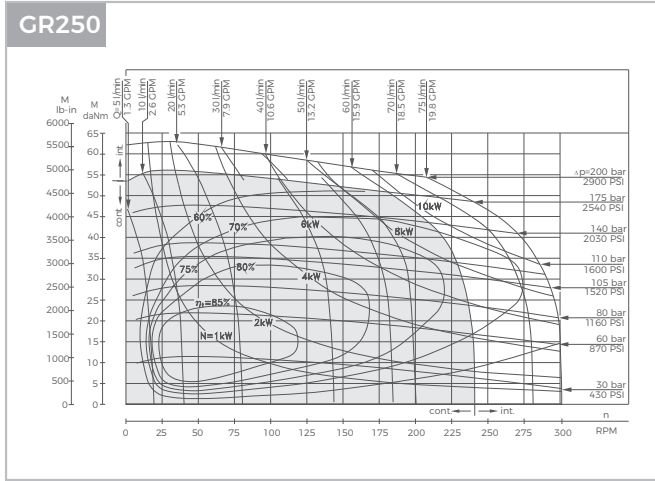

The function diagrams data is for average performance of randomly selected motors at backpressure. 5–10 bar [72.5–145 PSI] and oil with viscosity of 32 mm²/s [150 SUS] at 50°C [122°F].

GR Dimensions and Mountings

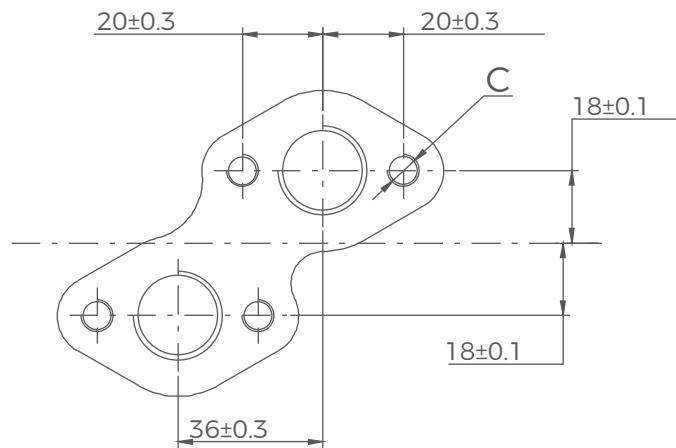
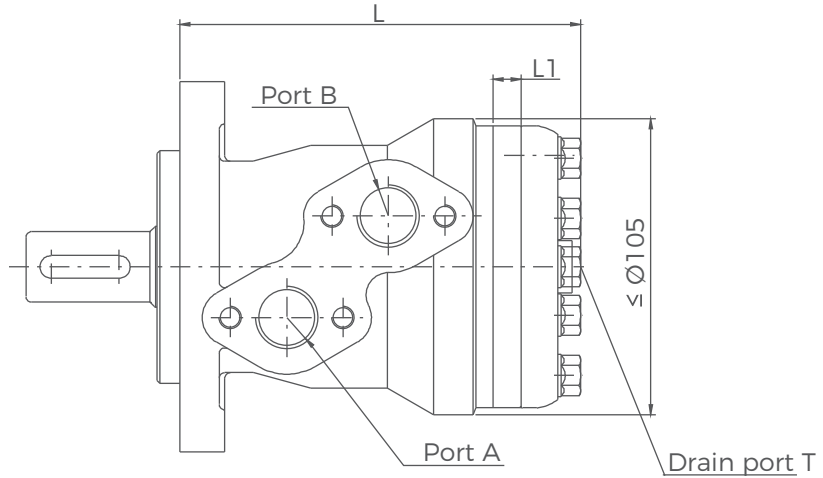

Model	L(mm)	L1(mm)
GR50	140	10
GR80	146	16
GR100	150	20
GR125	155	25
GR160	161.5	30.5
GR200	170	38.1
GR250	180	50
GR315	192	62
GR400	207	76

Mounting	G1 (depth)	M1 (depth)	U2 (depth)	U1 (depth)	G2 (depth)
P(A,B)	G1/2(15)	M22x1.5(15)	7/8-14 O-ring(17)	1/2-14NPTF(15)	PT(RC)1/2(15)
T	G1/4(12)	M14x1.5(12)	7/16-20UNF(12)	7/16-20UNF(12)	PT(RC)1/4(9.7)
C	4-M8(13)	4-M8(13)	4-5/16-18UNC(13)	4-5/16-18UNC(13)	4-M8(13)

GR with Manifold Dimensions and Mountings

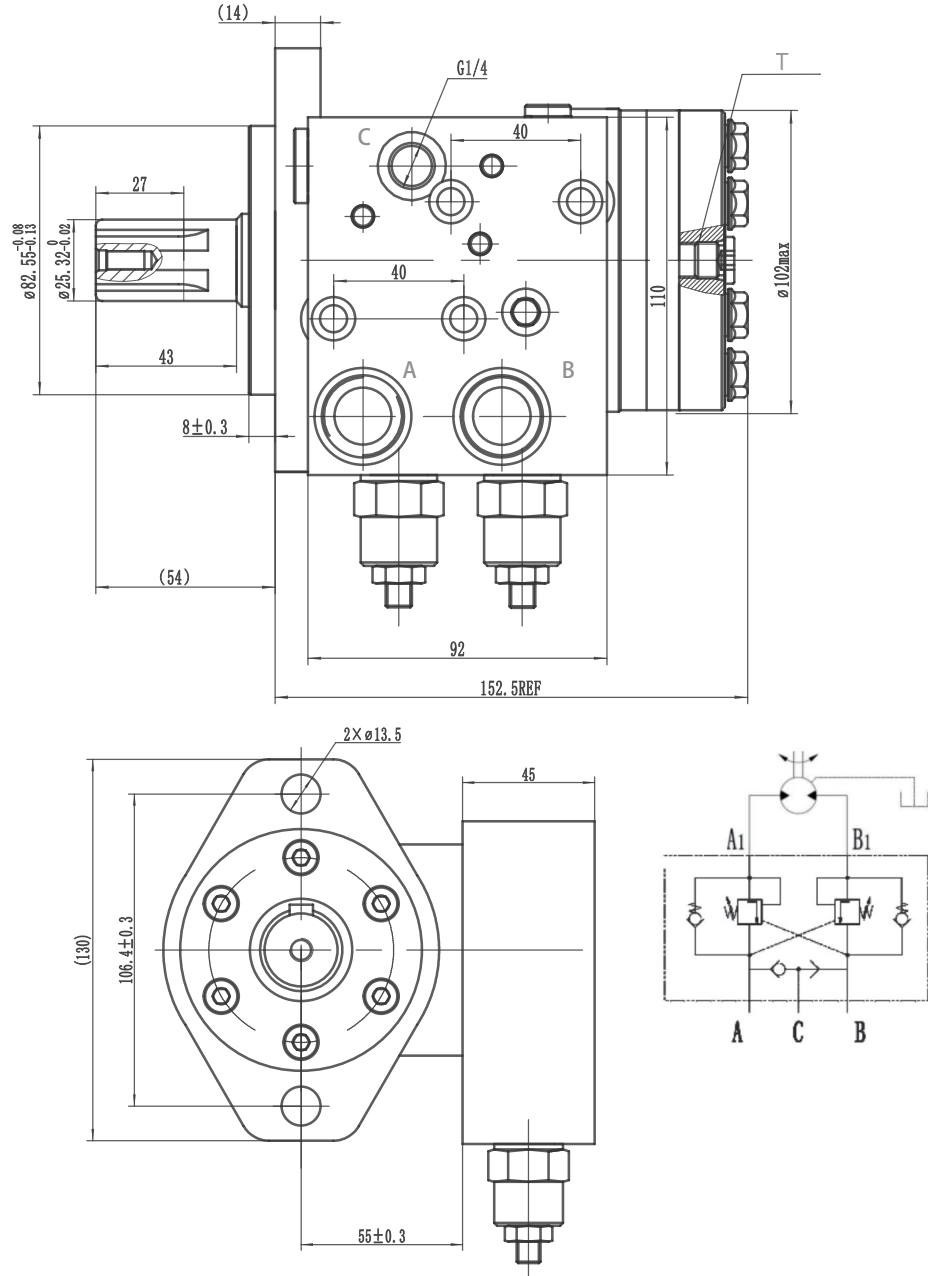

Model	L(mm)
GR50	140
GR80	146
GR100	150
GR125	155
GR160	161.5
GR200	170
GR250	180
GR315	192
GR400	207

GR with Speed Sensor Dimensions and Mountings

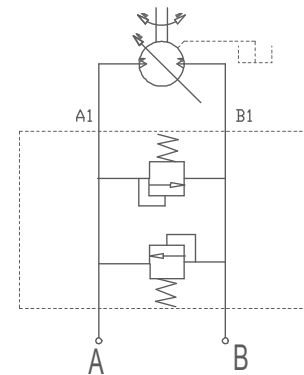
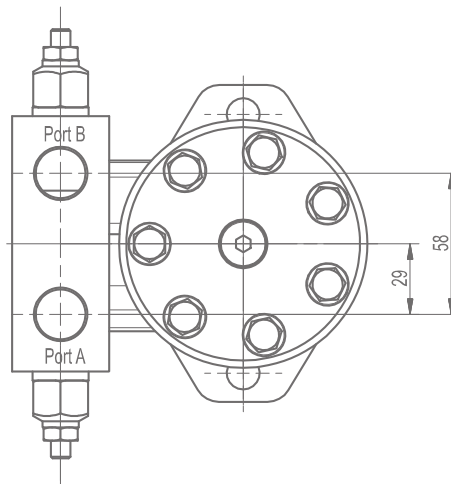
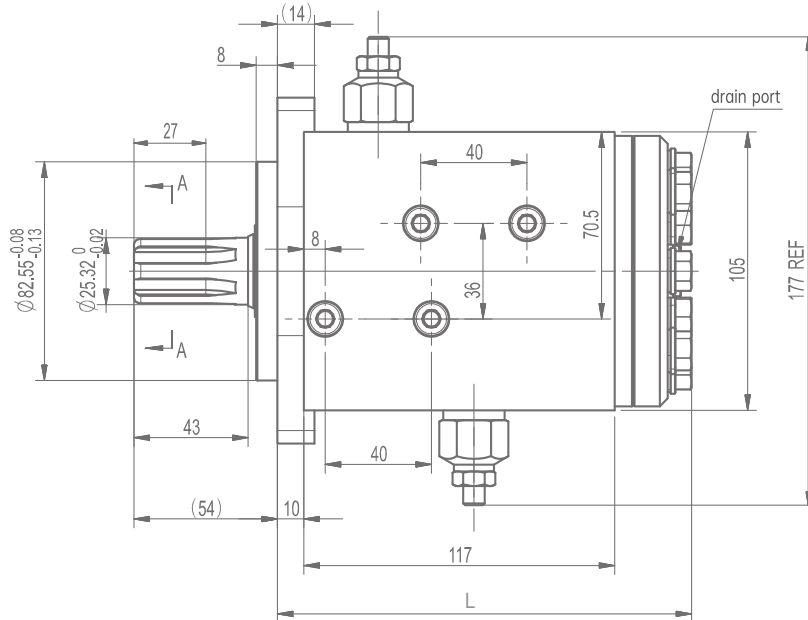

Model	L(mm)
GR50	140
GR80	146
GR100	150
GR125	155
GR160	161.5
GR200	170
GR250	180
GR315	192
GR400	207



GR with Speed Sensor Dimensions and Mountings

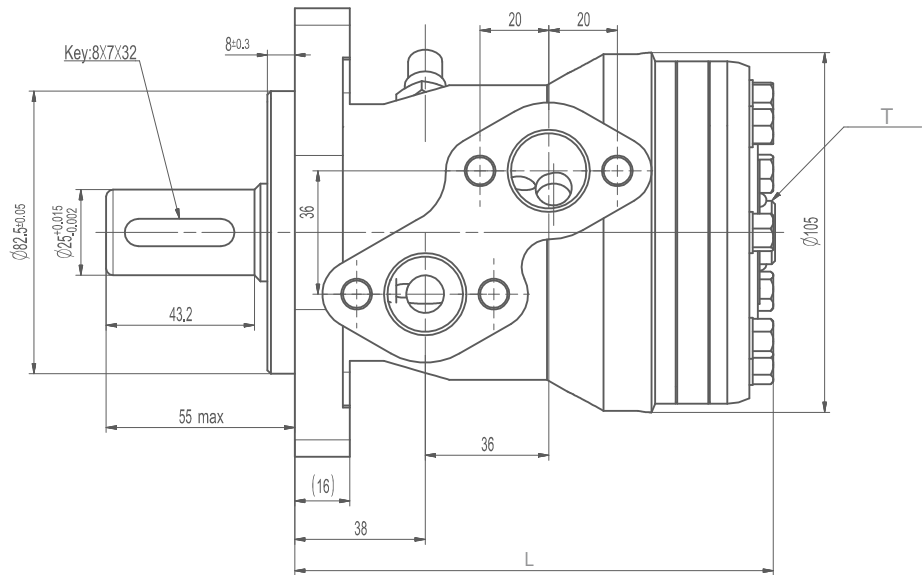

Model	L(mm)
GR50	140
GR80	146
GR100	150
GR125	155
GR160	161.5
GR200	170
GR250	180
GR315	192
GR400	207

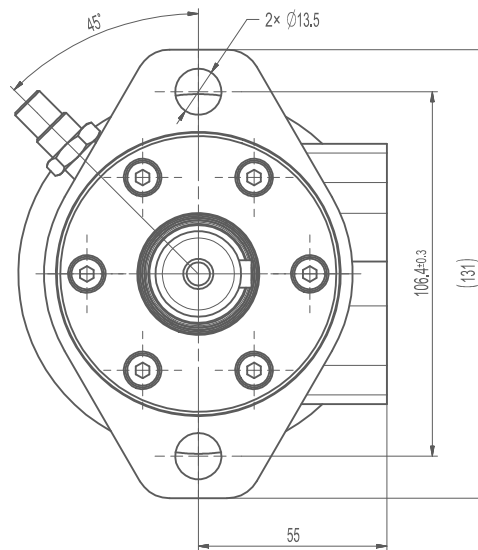

Mounting	G1 (depth)	M1 (depth)	U2 (depth)	U1 (depth)	G2 (depth)
P(A, B)	G1/2(15)	M22x1.5(15)	7/8-14 O-ring(17)	1/2-14NPTF(15)	PT(RC)1/2(15)
T	G1/4(12)	M14x1.5(12)	7/16-20UNF(12)	7/16-20UNF(12)	PT(RC)1/4(9.7)
C	4-M8(13)	4-M8(13)	4-5/16-18UNC(13)	4-5/16-18UNC(13)	4-M8(13)

GRW Dimensions and Mountings

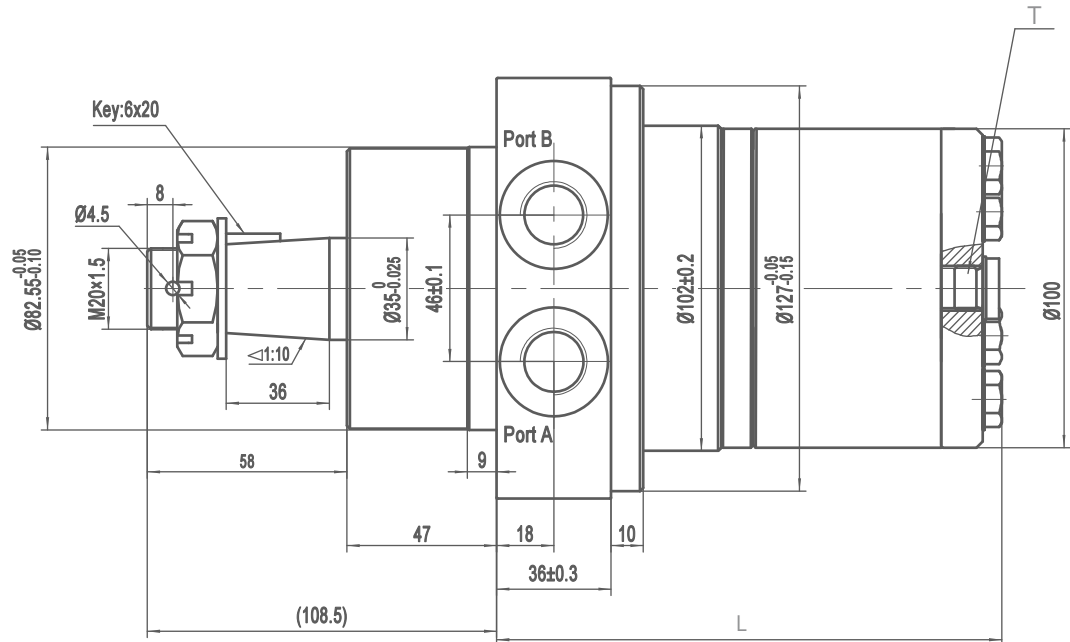

Model	L(mm)
GRW50	120
GRW80	125
GRW100	132
GRW125	139
GRW160	146
GRW200	153
GRW250	160
GRW315	167
GRW400	174

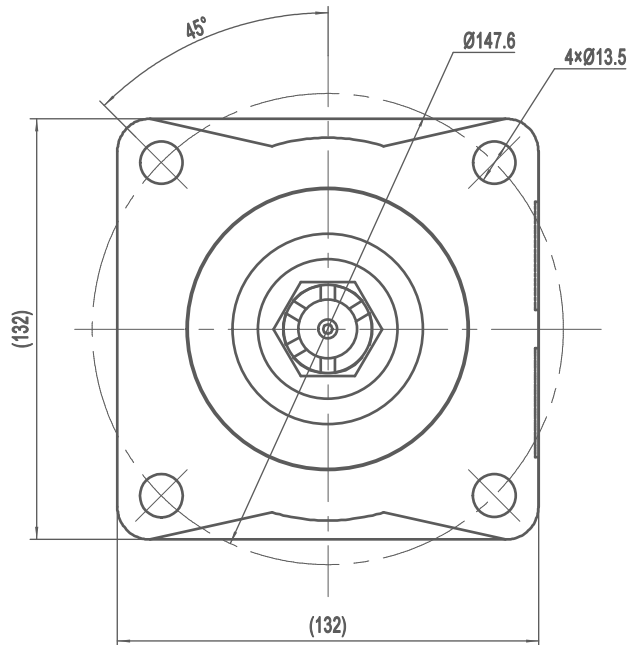

Mounting	G1 (depth)	M1 (depth)	U2 (depth)	U1 (depth)	G2 (depth)
P(A, B)	G1/2(15)	M22x1.5(15)	7/8-14 O-ring(17)	1/2-14NPTF(15)	PT(RC)1/2(15)
T	G1/4(12)	M14x1.5(12)	7/16-20UNF(12)	7/16-20UNF(12)	PT(RC)1/4(9.7)
C	4-M8(13)	4-M8(13)	4-5/16-18UNC(13)	4-5/16-18UNC(13)	4-M8(13)

GR Flange Covers Dimensions

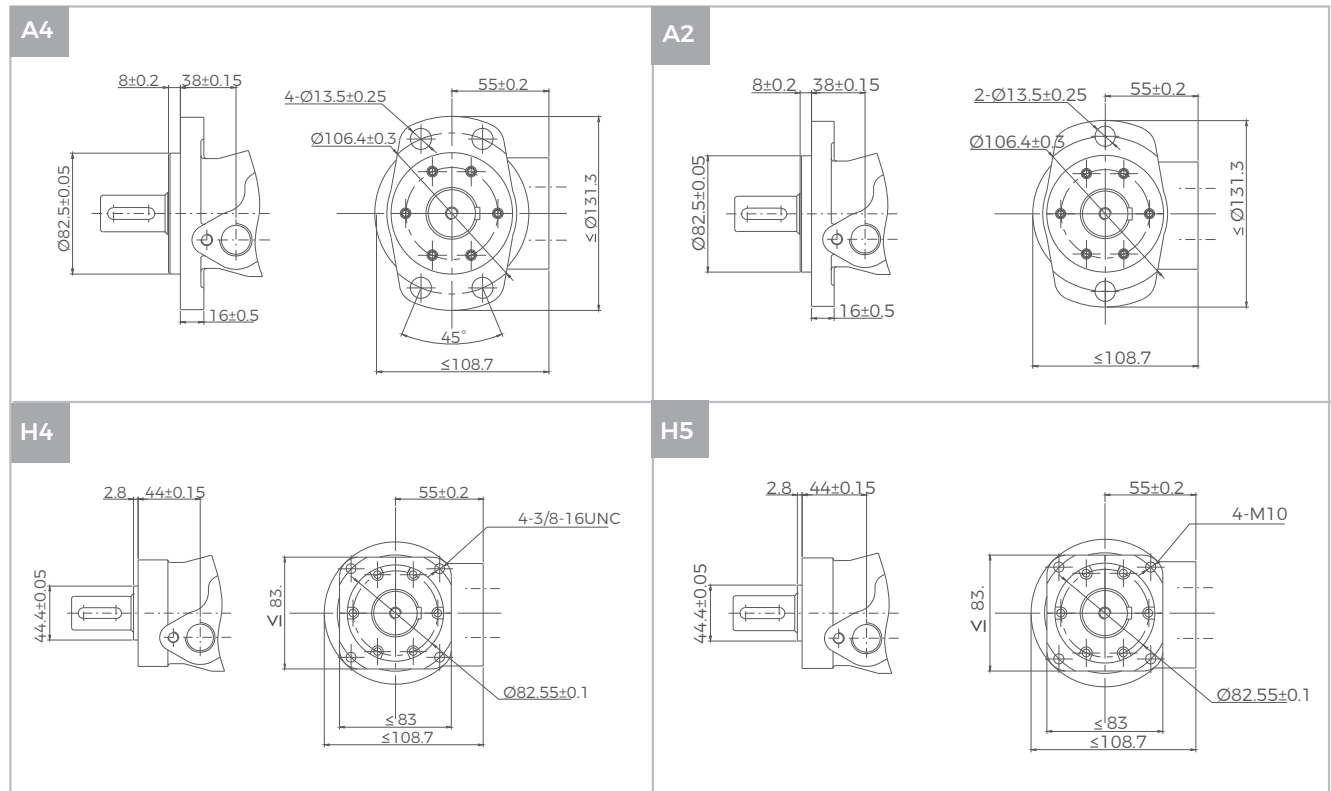

GR Shafts Dimensions

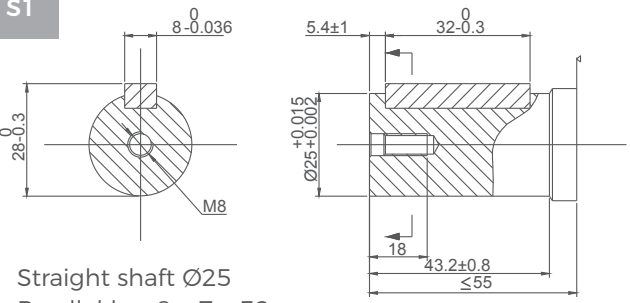
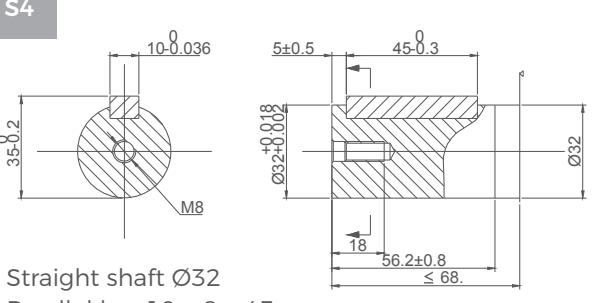
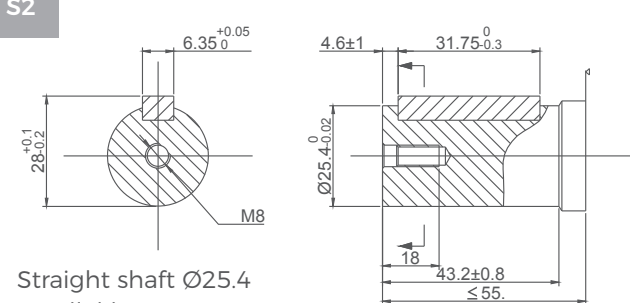
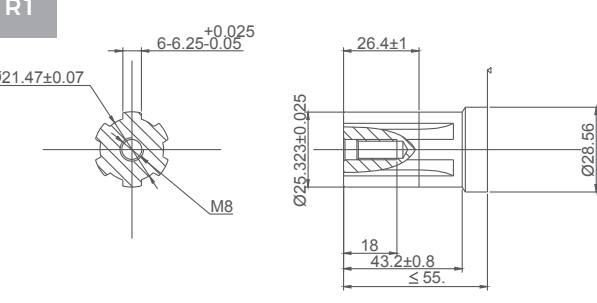
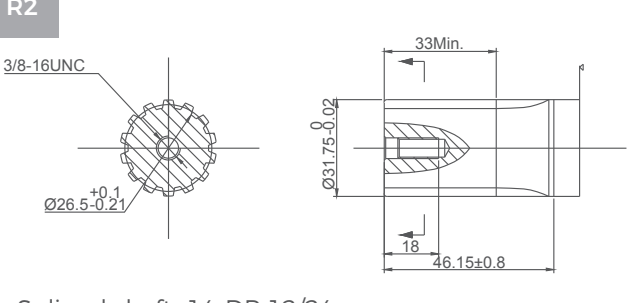
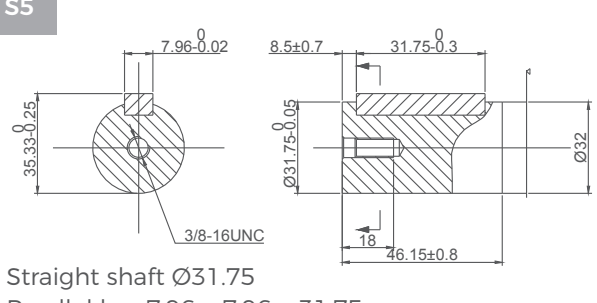
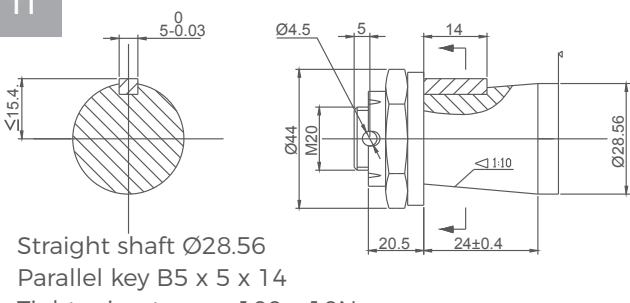
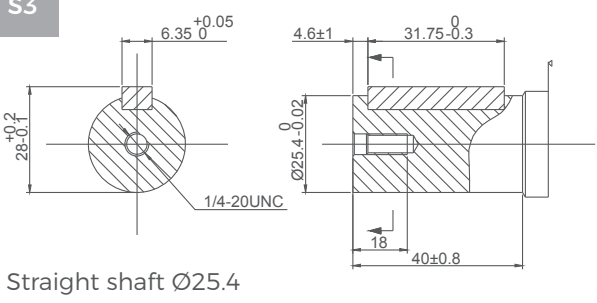
<p>S1</p>  <p>Straight shaft $\text{Ø}25$ Parallel key 8 x 7 x 32</p>	<p>S4</p>  <p>Straight shaft $\text{Ø}32$ Parallel key 10 x 8 x 45</p>
<p>S2</p>  <p>Straight shaft $\text{Ø}25.4$ Parallel key 6.35 x 6.35 x 31.75</p>	<p>R1</p>  <p>Splined shaft SAE 6B</p>
<p>R2</p>  <p>Splined shaft 14-DP 12/24</p>	<p>S5</p>  <p>Straight shaft $\text{Ø}31.75$ Parallel key 7.96 x 7.96 x 31.75</p>
<p>T1</p>  <p>Straight shaft $\text{Ø}28.56$ Parallel key B5 x 5 x 14 Tightening torque $100 \pm 10\text{Nm}$</p>	<p>S3</p>  <p>Straight shaft $\text{Ø}25.4$ Parallel key 6.35 x 6.35 x 31.75</p>

GR Series Hydraulic Motors

Permissible shaft seal pressure

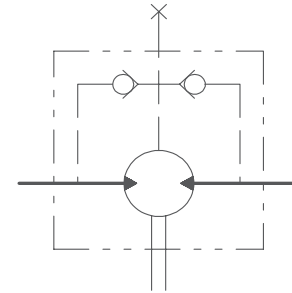
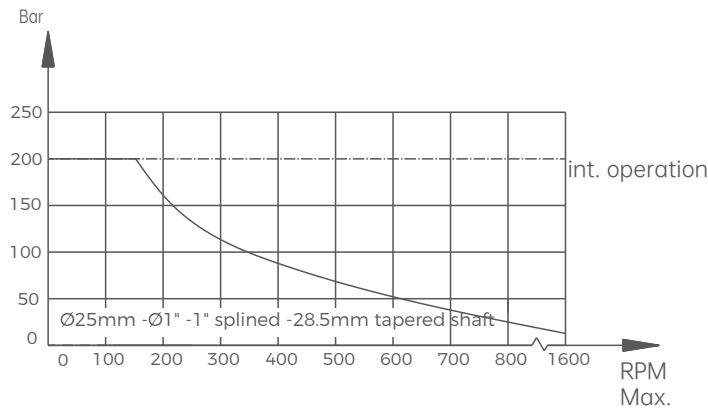

GR with standard shaft seal check valves and without use of drain connection: The pressure on the shaft seal never exceeds the pressure in the return line.

GR with standard shaft seal, check valves and with drain connection: The shaft seal pressure equals the pressure on the drain line.

Drain Port

In applications without drain line, output shaft seal exceeds a bit of the pressure in the return line. In applications using the drain line, the pressure of output shaft seal equals the pressure in drain line.

Standard direction of shaft rotation: Standard

When facing shaft end of motor, shaft to rotate:
Clockwise. When port "A" is pressurized.
Counter-clockwise port "B" is pressurized.

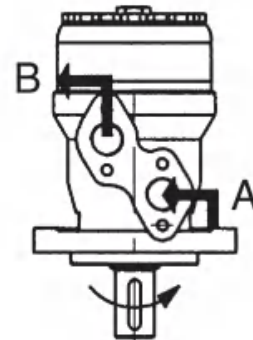

Output shaft axial and radial force

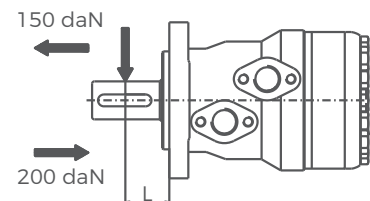
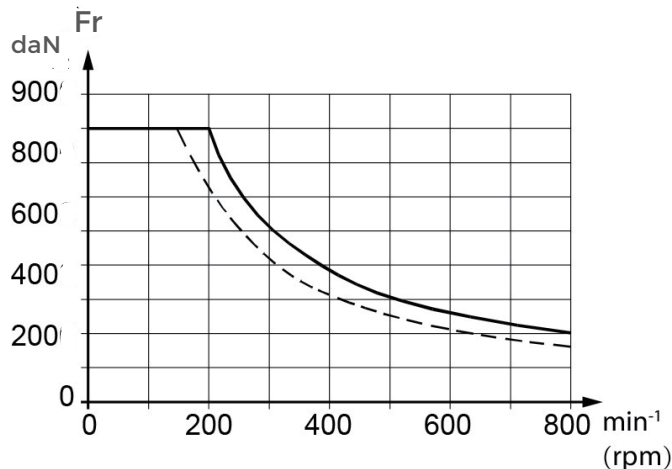

$$Fr = \frac{800}{n} * \frac{25000}{95 + L} \text{ (daN)}$$

Fr = Radial Force (daN)

L = Distance (mm)

n = Speed (rpm)

Rhomb-flange L = 30mm

Square-flange L = 24mm



GRA Series Hydraulic Motors

Options

- Flange connection
- Motor with needle roller bearing
- Side and rear ports
- Shaft seal for high and low pressure
- Straight, splined and tapered shafts
- Metric and BSPP ports
- Other special features

Applications

- Sweepers
- Snow Removal
- Combine Harvesters
- Winches
- Sprayers
- Skid Steer Attachments
- Conveyers



General

Max.Displacement	cm ³ /rev [in ³ /rev]	375[22.88]
Max.Speed	RPM	700
Max.Torque	daNm [lb-in]	cont.:115 [1017.75] int.:505 [4469.25]
Max.Output	kW [HP]	48.7[65.3]
Max.Pressure Drop	bar [PSI]	cont.:140 [2030] int.:175[2540]
Max.Oil Flow	lpm [GPM]	16 [21.44]
Pressure fluid		Mineral based- HLP (DIN 51524) or HM (ISO 6743/4)
Temperature Range	°C [°F]	-40—140[-104—284]
Optimal Viscosity range	mm ² /s [SUS]	20—75[98—347]
Filtration		ISO code 20/16 (Min.recommended fluid filtration of 25 microns)

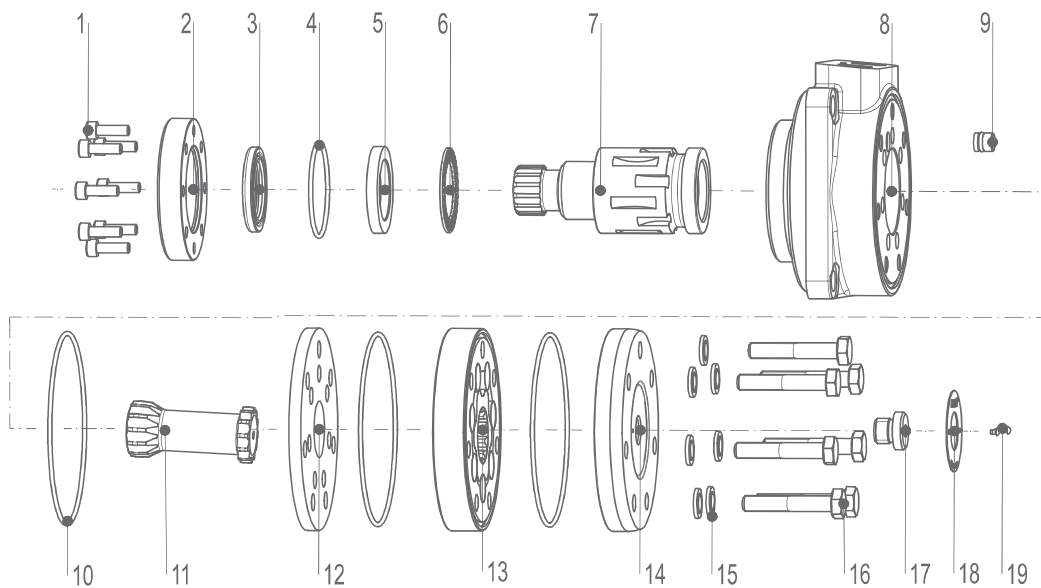

- | | | | |
|-----------------|-------------------------|--------------------------|---------------------|
| 1. Bolt | thrust rolling bearings | 11. Transmission shaft | 16. Rear cover bolt |
| 2. Front cover | 7. Output shaft | 12. Spacer disk | 17. E plug |
| 3. Shaft seal | 8. Shell | 13. Stator sub | 18. Signage |
| 4. O-ring | 9. Sealing plug | 10 Output shaft | 19. Label rivets |
| 5. Flat bearing | 6. Flat | 11 Needle roller bearing | |
| | | 14. Rear cover | |

Ordering Code

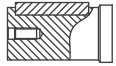
GRA SERIES	DISP	FLANGE	SHAFT	PORTS	ROTATION	PAINT	FUNCTION
CODE	DISP cm ³ /rev [in ³ /rev]	CODE	FLANGE	CODE	SHAFT	CODE	ROTATION
50	50 [3.05]	HE	4-Ø10.5 square, pilot Ø100×10 	RM	DIN5482 B25×22h9 	A	Standard
80	80 [4.88]			R	Opposite		
100	100 [6.10]			CODE	PORTS	CODE	PAINT
125	125 [7.63]			GB	4xM5, 2×Ø7.5, G1/4	A	No Paint
160	160 [9.76]					B	Blue
200	200 [12.20]					C	Black
250	250 [15.25]					S	Silver grey
315	315 [19.22]					CODE	FUNCTION
375	375 [22.88]					A	Standard
						N	Big radial force
				D	No case drain		
				F	Free running		
				L	Low speed		
				V	High temp.		
				S	Low temp.		

GRA Specifications

Type		GRA50	GRA80	GRA100	GRA125	GRA160
Displacement cm ³ /rev [in ³ /rev]		50[3.05]	80[4.88]	100[6.10]	125[7.63]	160[9.76]
Max.Speed RPM	Cont.	580	435	400	320	250
	Int.	700	525	480	380	300
Max.Oil Flow	Cont.	30 [7.93]	35 [9.25]	40 [10.57]	40 [10.57]	40 [10.57]
lpm [GPM]	Int.	36 [9.51]	42 [11.10]	48 [12.68]	48 [12.68]	48 [12.68]
Max.Differential Pressure bar [PSI]	Cont.	140[2030]	175[2537.5]	175[2537.5]	175[2537.5]	130[1885]
	Int.	175[2537.5]	200[2900]	200[2900]	200[2900]	175[2537.5]
	Peak	225[3260]	225[3260]	225[3260]	225[3260]	225[3260]
Max. Inlet Pressure bar [PSI]	Cont.	175[2537.5]	175[2537.5]	175[2537.5]	175[2537.5]	175[2537.5]
	Int.	200[2900]	200[2900]	200[2900]	200[2900]	200[2900]
	Peak	225[3260]	225[3260]	225[3260]	225[3260]	225[3260]
Max. return pressure with drain line	Cont.	175[2537.5]	175[2537.5]	175[2537.5]	175[2537.5]	175[2537.5]
	Int.	200[2900]	200[2900]	200[2900]	200[2900]	200[2900]
	Peak	225[3260]	225[3260]	225[3260]	225[3260]	225[3260]
Max.starting pressure with unloaded shaft bar [PSI]		10[145]	10[145]	10[145]	10[145]	10[145]
Max.Torque Nm [[lb-in]	Cont.	115 [1017.75]	225 [1991.25]	280 [2478]	350 [3097.5]	330 [2920.5]
	Int.	135 [1194.75]	255 [2256.75]	315 [2787.75]	400 [3540]	445 [3938.25]
Max.Performance kW [HP]	GRA	10.5 [14.07]	14 [18.76]	16 [21.44]	16 [21.44]	14 [18.76]

Type		GRA200	GRA250	GRA315	GRA375
Displacement cm ³ /rev [in ³ /rev]		200[12.20]	250[15.25]	315[19.22]	375[22.88]
Max.Speed RPM	Cont.	200	160	127	107
	Int.	240	195	152	129
Max.Oil Flow	Cont.	40 [10.57]	40 [10.57]	40 [10.57]	40 [10.57]
lpm [GPM]	Int.	48 [12.68]	48 [12.68]	48 [12.68]	48 [12.68]
Max.Differential Pressure bar [PSI]	Cont.	110[1595]	90[1305]	70[1015]	55[797.5]
	Int.	140[2030]	115[1667.5]	100[1450]	85[1232.5]
	Peak	225[3260]	200[2900]	150[2537.5]	130
Max. Inlet Pressure bar [PSI]	Cont.	175[2537.5]	175[2537.5]	175[2537.5]	175[2537.5]
	Int.	200[2900]	200[2900]	200[2900]	200[2900]
	Peak	225[3260]	225[3260]	225[3260]	225[3260]
Max. return pressure with drain line	Cont.	175[2537.5]	175[2537.5]	175[2537.5]	175[2537.5]
	Int.	200[2900]	200[2900]	200[2900]	200[2900]
	Peak	225[3260]	225[3260]	225[3260]	225[3260]
Max.starting pressure with unloaded shaft bar [PSI]		10[145]	10[145]	10[145]	10[145]
Max.Torque Nm [[lb-in]	Cont.	350 [3097.5]	355 [3141.75]	350 [3097.5]	325 [2876.25]
	Int.	445 [3938.25]	455 [4026.75]	505 [4469.25]	505 [4469.25]
Max.Performance kW [HP]	GRA	11.2 [15.008]	9.2 [12.328]	8 [10.72]	6.8 [9.112]



GRA Dimensions and Mountings

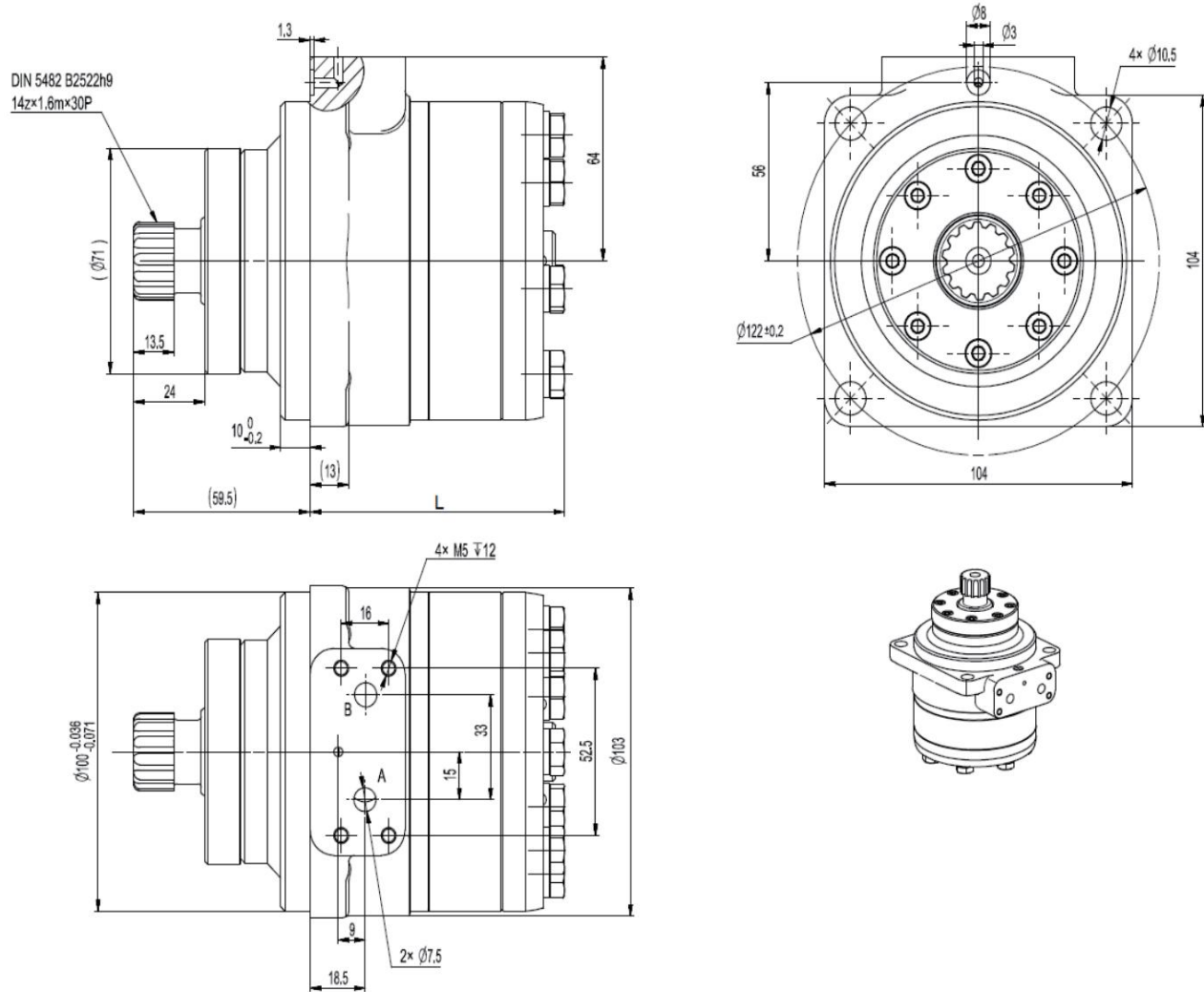

Model	L(mm)
GRA 50	71
GRA 80	77
GRA 100	81
GRA 125	86
GRA160	91
GRA 200	99
GRA 250	104
GRA 315	111
GRA 375	116

GRA with Manifold Dimensions and Mountings

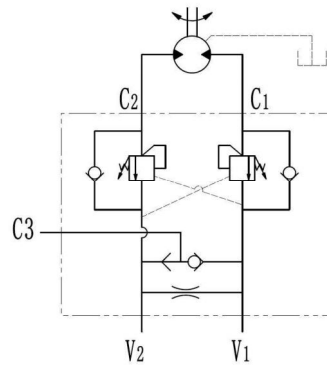
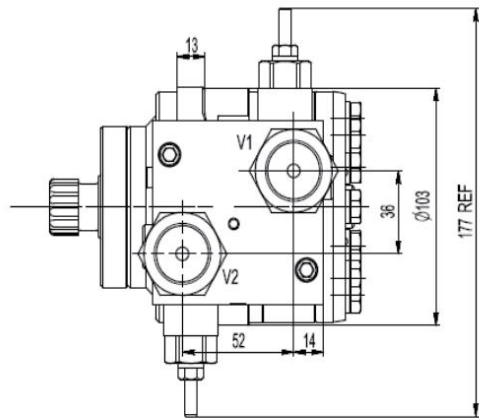
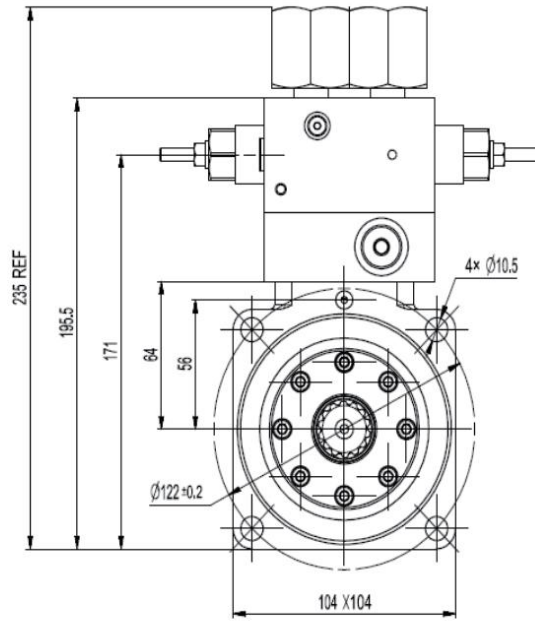
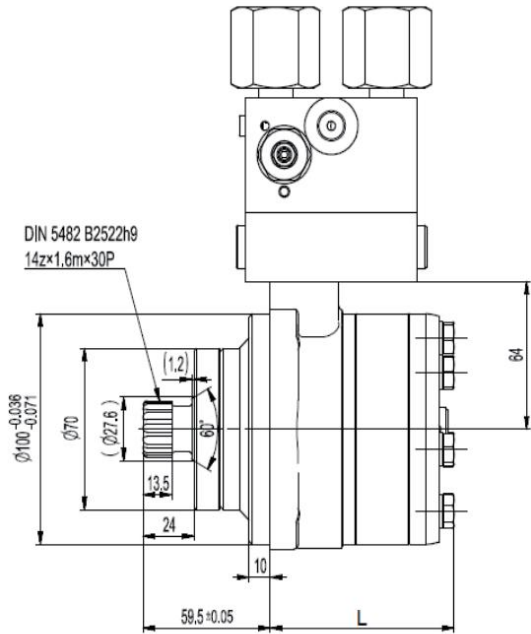

GRS Series Hydraulic Motors

Options

- Flange connection
- Motor with needle bearing
- Side and rear ports
- Straight, splined and tapered shafts
- Shaft seal for high and low pressure
- Metric and BSPP ports
- Speed sensing
- Other special features

Applications

- Conveyors
- Feeding equipment of robots and manipulators
- Metal working machines
- Textile machines
- Agricultural machines
- Food industries
- Lawn mower



General

Max. Displacement	cm ³ /rev [in ³ /rev]	397 [24.4]
Max. Speed	RPM	970
Max. Torque	daNm [lb-in]	cont.: 61 [5400] int.: 69 [6100]
Max. Output	kW [HP]	15 [20.1]
Max. Pressure Drop	bar [PSI]	cont.: 175 [2540] int.: 200 [2900]
Max. Oil Flow	lpm [GPM]	75 [20]
Min. Speed	RPM	10
Operating Fluid		Mineral based- HLP (DIN 51524) or HM (ISO 6743/4)
Temperature Range	°C [°F]	-40–140[-140–284]
Optimal Viscosity range	mm ² /s [SUS]	20–75[98–347]
Filtration		ISO code: 20/16 (Min. recommended fluid filtration of 25 microns)

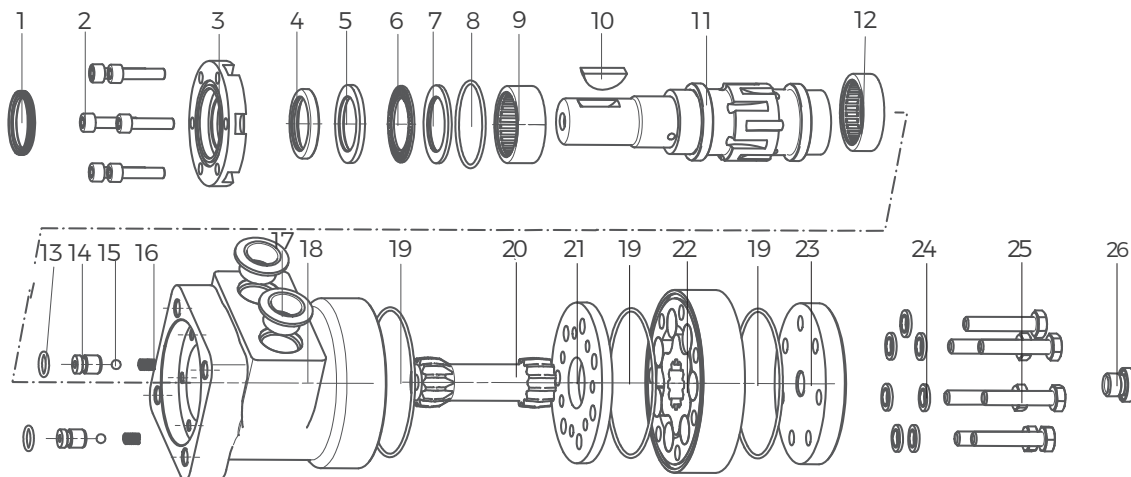

- | | | | | |
|------------------|-------------------------|--------------------------|------------------------------|------------------------|
| 1 Anti-dust ring | 6 Bearing | 11 Output shaft | 16 Spring | 21 Spacer |
| 2 Bolt | 7 Retainer | 12 Needle roller bearing | 17 Oil-resistant rubber plug | 22 Stator assembly |
| 3 Front Cover | 8 O-ring seal | 13 O-ring seal | 18 Housing | 23 Rear cover |
| 4 Shaft seal | 9 Needle roller bearing | 14 Check valve | 19 O-ring seal | 24 Washer |
| 5 Retainer | 10 woodruff key | 15 Steel ball | 20 Transmission shaft | 25 Bolt |
| | | | | 26 External drain plug |

Specifications

Type		GRS50	GRS80	GRS100	GRS125	GRS160
Displacement, cm ³ /rev [in ³ /rev]		51,5[3.14]	80,3[4.90]	99,8[6.09]	125,7[7.67]	159,6[9.74]
Max. Speed,	Cont.	775	750	600	457	375
RPM	Int.*	970	940	750	600	470
Max. Torque	Cont.	10[900]	20[1770]	24[2125]	30[2655]	39[3450]
daNm [lb-in]	Int.*	13[1150]	22[1947]	28[2480]	34[3010]	43[3805]
	Peak**	17[1505]	27[2390]	32[2832]	37[3275]	46[4070]
Max. Output	Cont.	7[9.5]	125[17]	13[17.4]	125[16.8]	115[15.4]
kW [HP]	Int.*	85[11.9]	15[20.1]	15[20.1]	145[19.5]	14[18.8]
Max. Pressure Drop	Cont.	140[2030]	175[2540]	175[2540]	175[2540]	175[2540]
bar [PSI]	Int.*	175[2540]	200[2900]	200[2900]	200[2900]	200[2900]
	Peak**	225[3260]	225[3260]	225[3260]	225[3260]	225[3260]
Max. Oil Flow	Cont.	40[10.5]	60[15.8]	60[15.8]	60[15.8]	60[15.8]
lpm [GPM]	Int.*	50[13.2]	75[19.8]	75[19.8]	75[19.8]	75[19.8]
Max. Inlet Pressure	Cont.	175[2540]	175[2540]	175[2540]	175[2540]	175[2540]
bar [PSI]	Int.*	200[2900]	200[2900]	200[2900]	200[2900]	200[2900]
	Peak**	225[3260]	225[3260]	225[3260]	225[3260]	225[3260]
Max. Return Pressure	Cont.	175[2540]	175[2540]	175[2540]	175[2540]	175[2540]
without Drain Line	Int.*	200[2900]	200[2900]	200[2900]	200[2900]	200[2900]
bar [PSI]	Peak**	225[3260]	225[3260]	225[3260]	225[3260]	225[3260]
Max. Starting Pressure						
with Unloaded Shaft, bar [PSI]		10[145]	10[145]	10[145]	9[130]	7[102]
Min. Starting Torque	At max. press. drop Cont.	8[710]	15[1330]	20[1770]	25[2215]	32[2832]
daNm [lb-in]	At max. press. drop Int.*	10[885]	17[1505]	23[2035]	28[2480]	37[3275]
Min. Speed, RPM		10	10	10	10	10
Weight, kg [lb]						
For rear port + 0.650 [1.433]	GRS	6,9[15.2]	7[15.4]	7,3[16.1]	7,4[16.3]	7,6[15.4]



Specifications

Type		GRS200	GRS250	GRS315	GRS400
Displacement, cm ³ /rev [in ³ /rev]		199,8[12.19]	250,1[15.26]	315,7[19.26]	397[24.4]
Max. Speed, RPM	Cont.	300	240	190	150
	Int.*	375	300	240	190
Max. Torque daNm [lb-in]	Cont.	45[4000]	54[4780]	55[4870]	61[5400]
	Int.*	50[4425]	61[5400]	69[6110]	69[6110]
	Peak**	56[4960]	71[6280]	84[7435]	87[7700]
Max. Output kW [HP]	Cont.	11[14.8]	10[13.4]	9[12]	78[10.5]
	Int.*	13[17.4]	12[16.1]	10[13.4]	106[14.2]
Max. Pressure Drop bar [PSI]	Cont.	175[2540]	175[2540]	135[1960]	110[1600]
	Int.*	200[2900]	200[2900]	175[2540]	140[2030]
	Peak**	225[3260]	225[3260]	225[3260]	225[3260]
Max. Oil Flow lpm [GPM]	Cont.	60[15.8]	60[15.8]	60[15.8]	60[15.8]
	Int.*	75[19.8]	75[19.8]	75[19.8]	75[19.8]
Max. Inlet Pressure bar [PSI]	Cont.	175[2540]	175[2540]	175[2540]	175[2540]
	Int.*	200[2900]	200[2900]	200[2900]	200[2900]
	Peak**	225[3260]	225[3260]	225[3260]	225[3260]
Max. Return Pressure without Drain Line bar [PSI]	Cont.	175[2540]	175[2540]	175[2540]	175[2540]
	Int.*	200[2900]	200[2900]	200[2900]	200[2900]
	Peak**	225[3260]	225[3260]	225[3260]	225[3260]
Max. Starting Pressure with Unloaded Shaft, bar [PSI]		5[73]	4[58]	3[44]	3[44]
Min. Starting Torque daNm [lb-in]	At max. press. drop Cont.	41[3630]	50[4425]	50[4425]	50[4425]
	At max. press. drop Int.*	46[4070]	55[4870]	66[5840]	61[5400]
Min. Speed, RPM		10	10	10	10
Weight, kg [lb] For rear port + 0,650 [1.433]	GRS	8,1[18.9]	8,5[18.7]	9,2[20.3]	9,9[21.8]



Function Diagrams

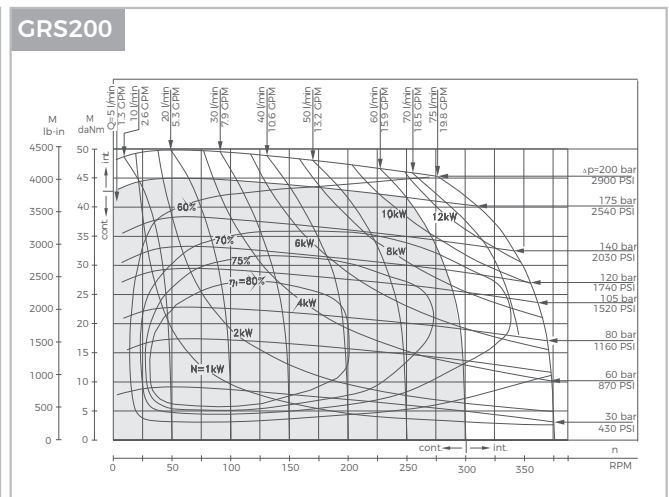
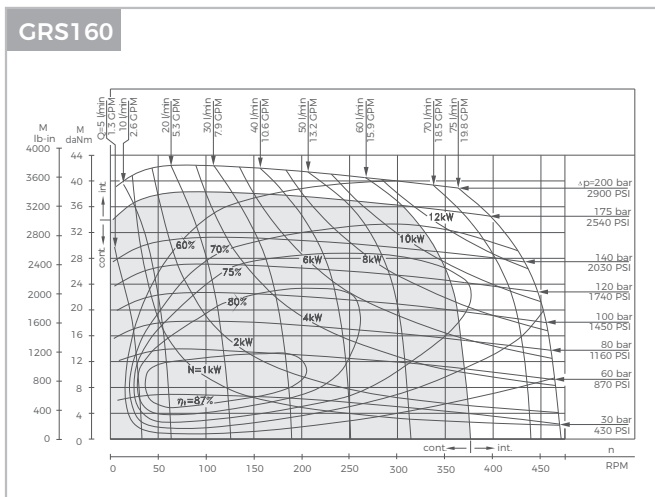
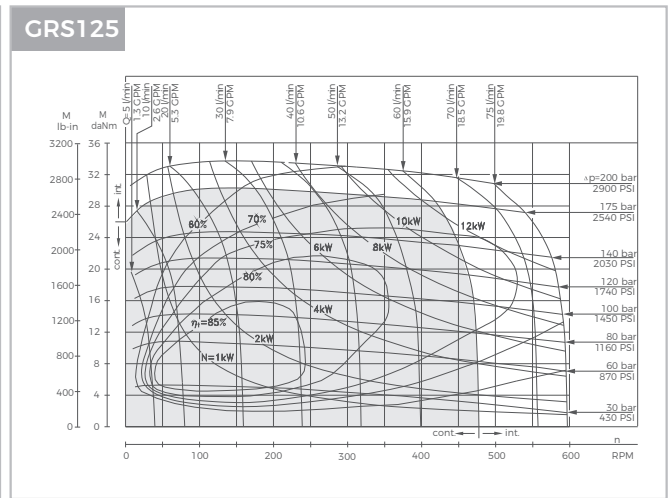
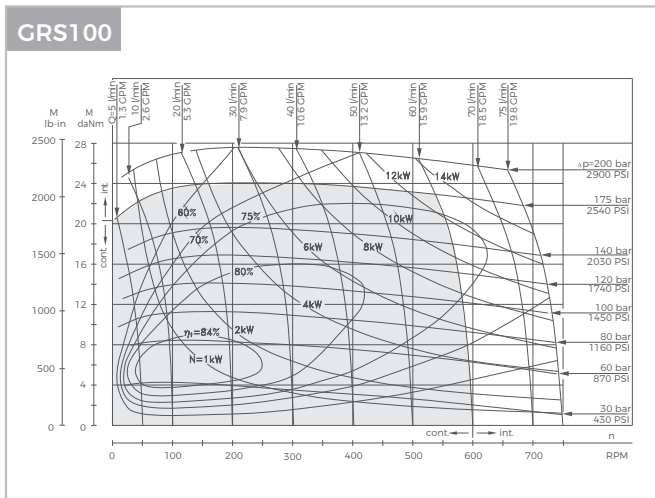
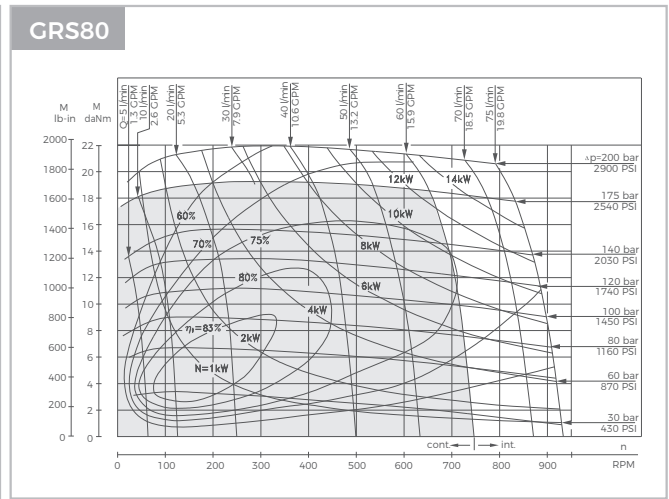
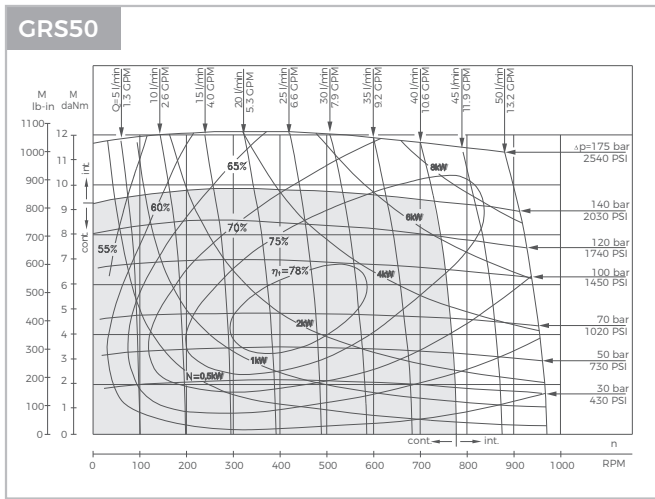

The function diagrams data is for average performance of randomly selected motors at backpressure. 5–10 bar [72.5–145 PSI] and oil with viscosity of 32 mm²/s [150 SUS] at 50°C [122°F].

Function Diagrams

GR250

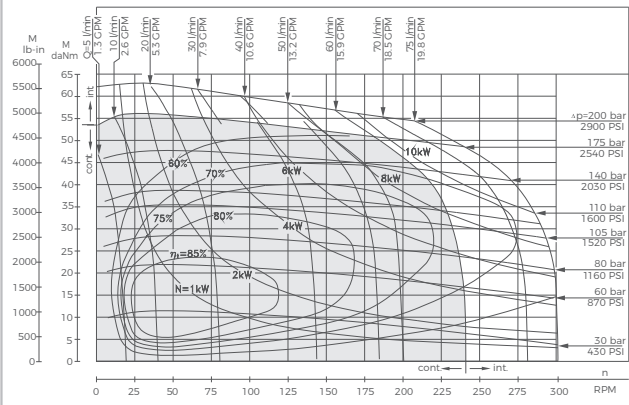

GRS315

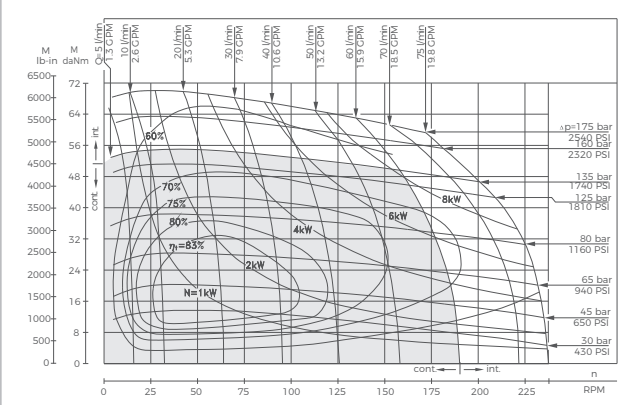

GRS400

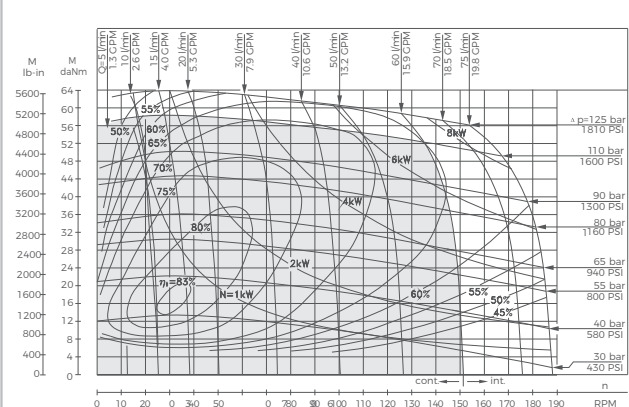

The function diagrams data is for average performance of randomly selected motors at backpressure. 5–10 bar [72.5–145 PSI] and oil with viscosity of 32 mm²/s [150 SUS] at 50°C [122°F].

GRS Dimensions and Mountings

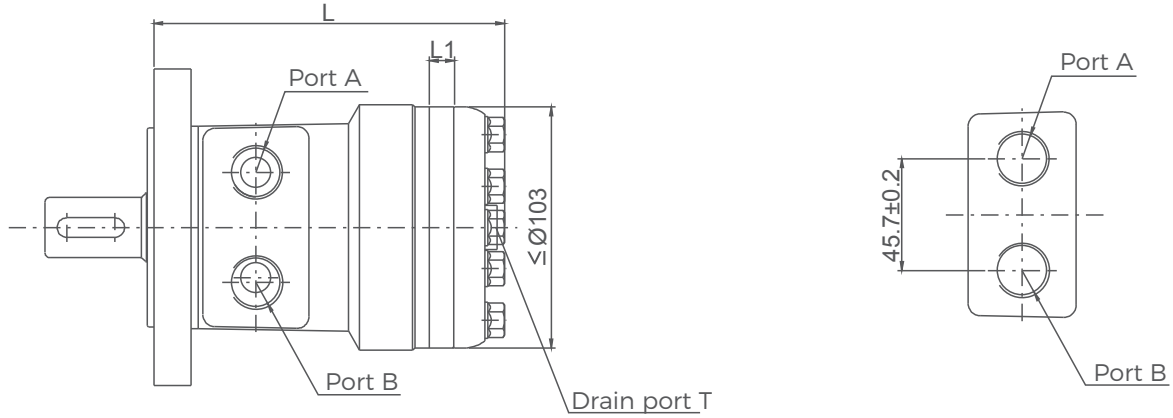

Model	L(mm)	L1(mm)
GRS50	146	10
GRS80	152	16
GRS100	156	20
GRS125	161	25
GRS160	166.5	30.5
GRS200	174	38.1
GRS250	186	50
GRS315	198	62
GRS400	213	76

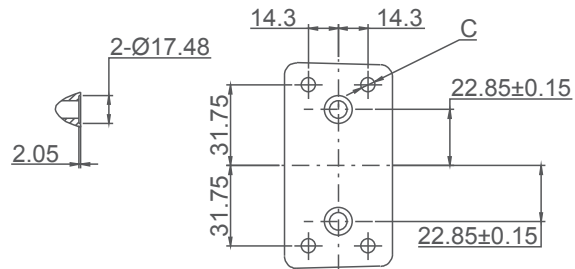

Mounting	G7 (depth)	U9 (depth)	UA (depth)	G8 (depth)	M2 (depth)	M3 (depth)	M4 (depth)	D1 (depth)	D2 (depth)
P(A, B)	G1/2(15)	7/8-14 O-ring(17)	1/2-14NPTF(15)	PT(RC)1/2(15)	M18 x 1.5(15)	M20 x 1.5(15)	M22 x 1.5(15)	10	10
T	G1/4(12)	7/16-20UNF(12)	7/16-20UNF(12)	PT(RC)1/4(9.7)	M10 x 1(12)	M10 x 1(12)	M10 x 1(12)	7/16-20UNF(12)	G1/4(12)
C	—	—	—	—	—	—	—	4-5/16-18UNC(13)	4-M8(13)

GRS with Speed Sensor Dimensions and Mountings

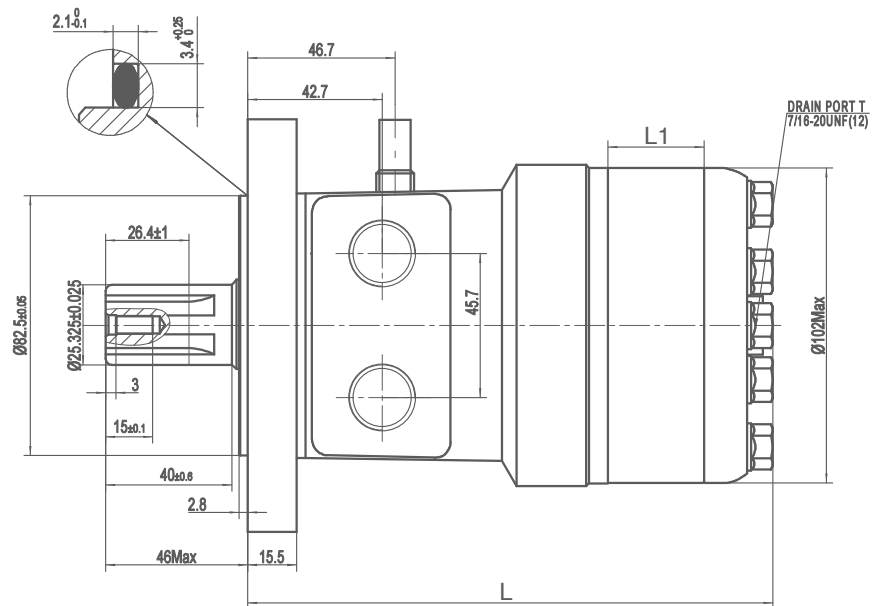

Model	L(mm)	L1(mm)
GRS50	146	10
GRS80	152	16
GRS100	156	20
GRS125	161	25
GRS160	166.5	30.5
GRS200	174	38.1
GRS250	186	50
GRS315	198	62
GRS400	213	76

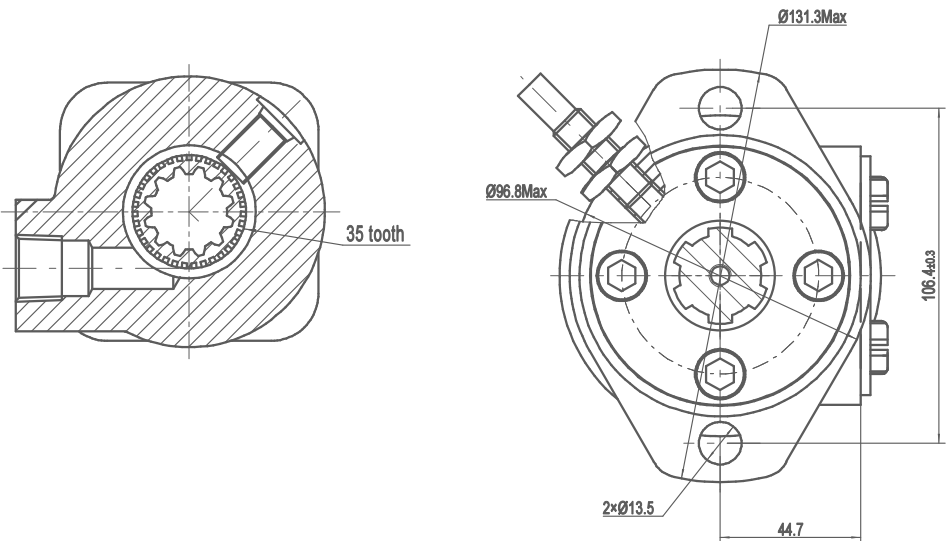

Mounting	G7 (depth)	U9 (depth)	UA (depth)	G8 (depth)	M2 (depth)	M3 (depth)	M4 (depth)	D1 (depth)	D2 (depth)
P(A, B)	G1/2(15)	7/8-14 O-ring(17)	1/2-14NPTF(15)	PT(RC)1/2(15)	M18 x 1.5(15)	M20 x 1.5(15)	M22 x 1.5(15)	10	10
T	G1/4(12)	7/16-20UNF(12)	7/16-20UNF(12)	PT(RC)1/4(9.7)	M10 x 1(12)	M10 x 1(12)	M10 x 1(12)	7/16-20UNF(12)	G1/4(12)
C	—	—	—	—	—	—	—	4-5/16-18UNC(13)	4-M8(13)

GRS with Brake Dimensions and Mountings

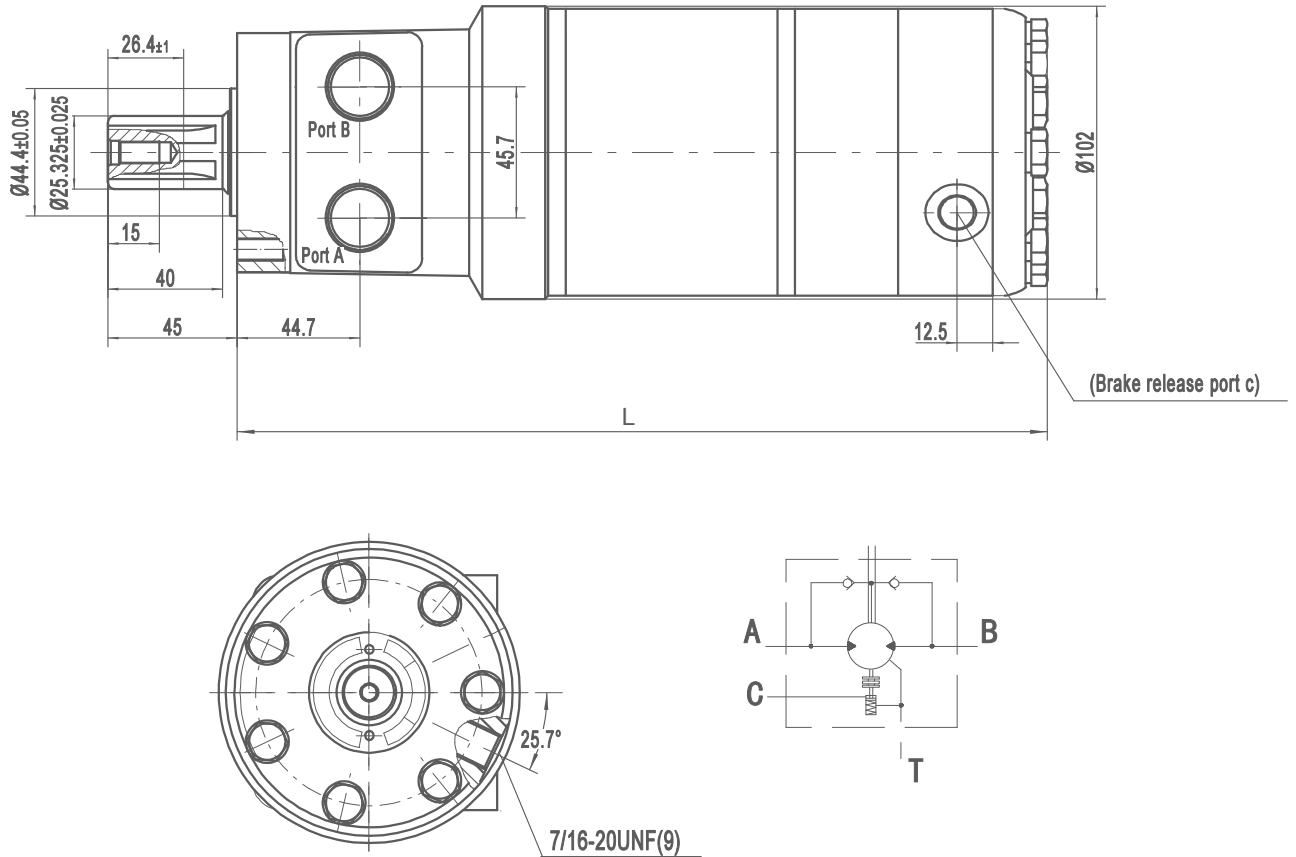

Min. opening pressure	1.7~2.2MPa
Max. inlet pressure	25MPa
Max. brake release port pressure	25MPa
Max. static torque	500~550Nm

Mounting	G7 (depth)	U9 (depth)	UA (depth)	G8 (depth)	M2 (depth)	M3 (depth)	M4 (depth)	D1 (depth)	D2 (depth)
P(A, B)	G1/2(15)	7/8-14 O-ring(17)	1/2-14NPTF(15)	PT(RC)1/2(15)	M18 x 1.5(15)	M20 x 1.5(15)	M22 x 1.5(15)	10	10
T	G1/4(12)	7/16-20UNF(12)	7/16-20UNF(12)	PT(RC)1/4(9.7)	M10 x 1(12)	M10 x 1(12)	M10 x 1(12)	7/16-20UNF(12)	G1/4(12)
C	—	—	—	—	—	—	—	4-5/16-18UNC(13)	4-M8(13)

GRS Flange Covers Dimensions

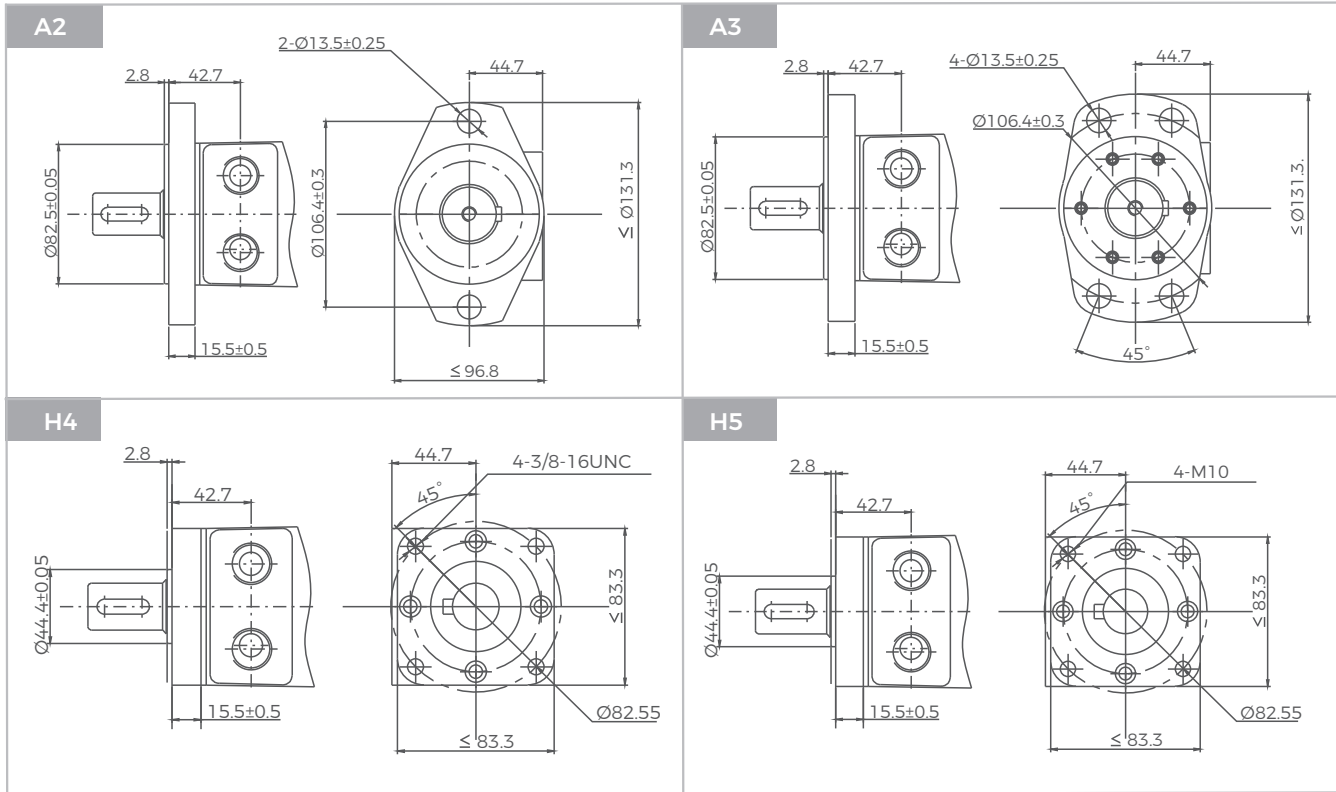

GRS Shafts Dimensions

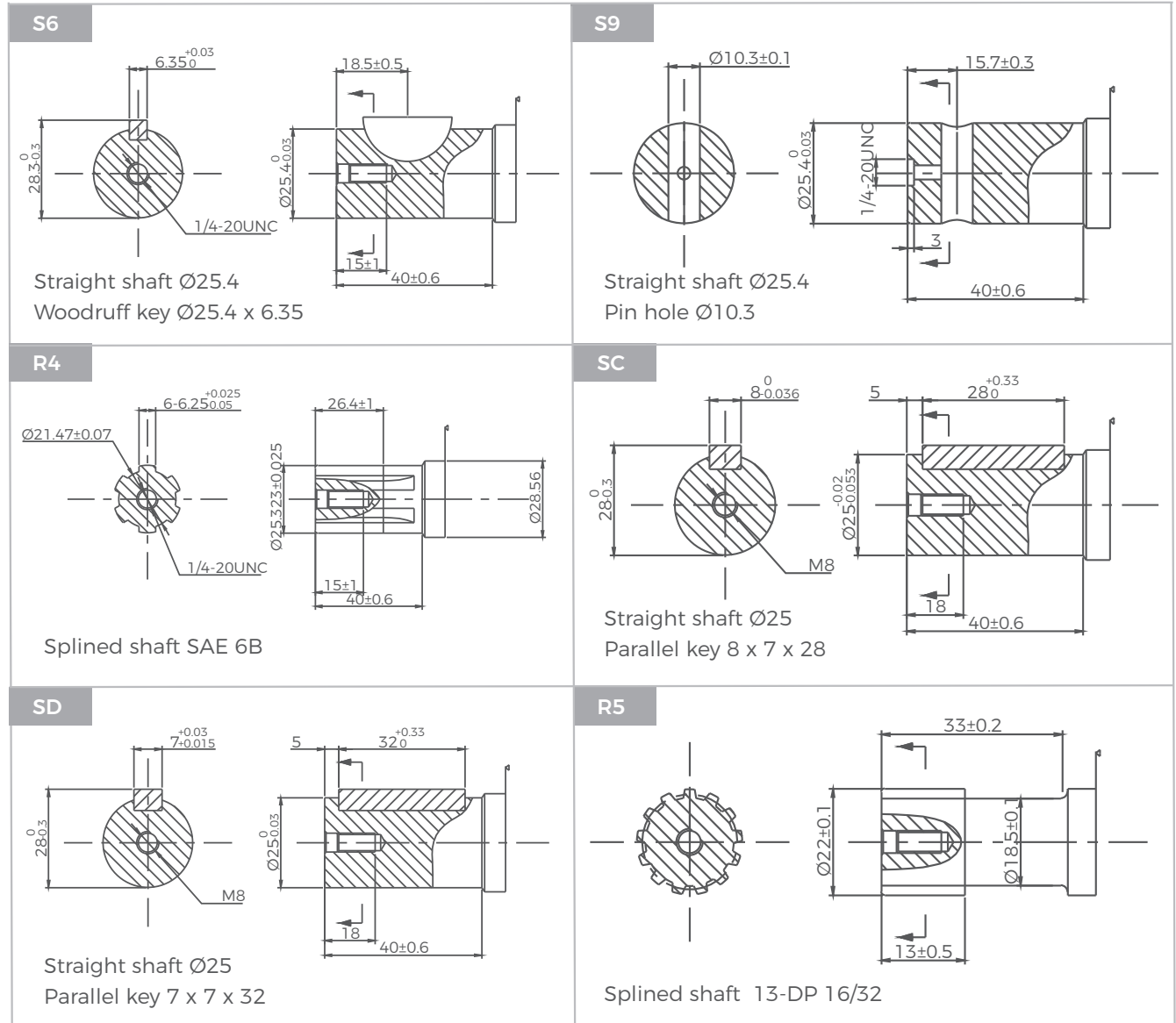

GRS Shafts Dimensions

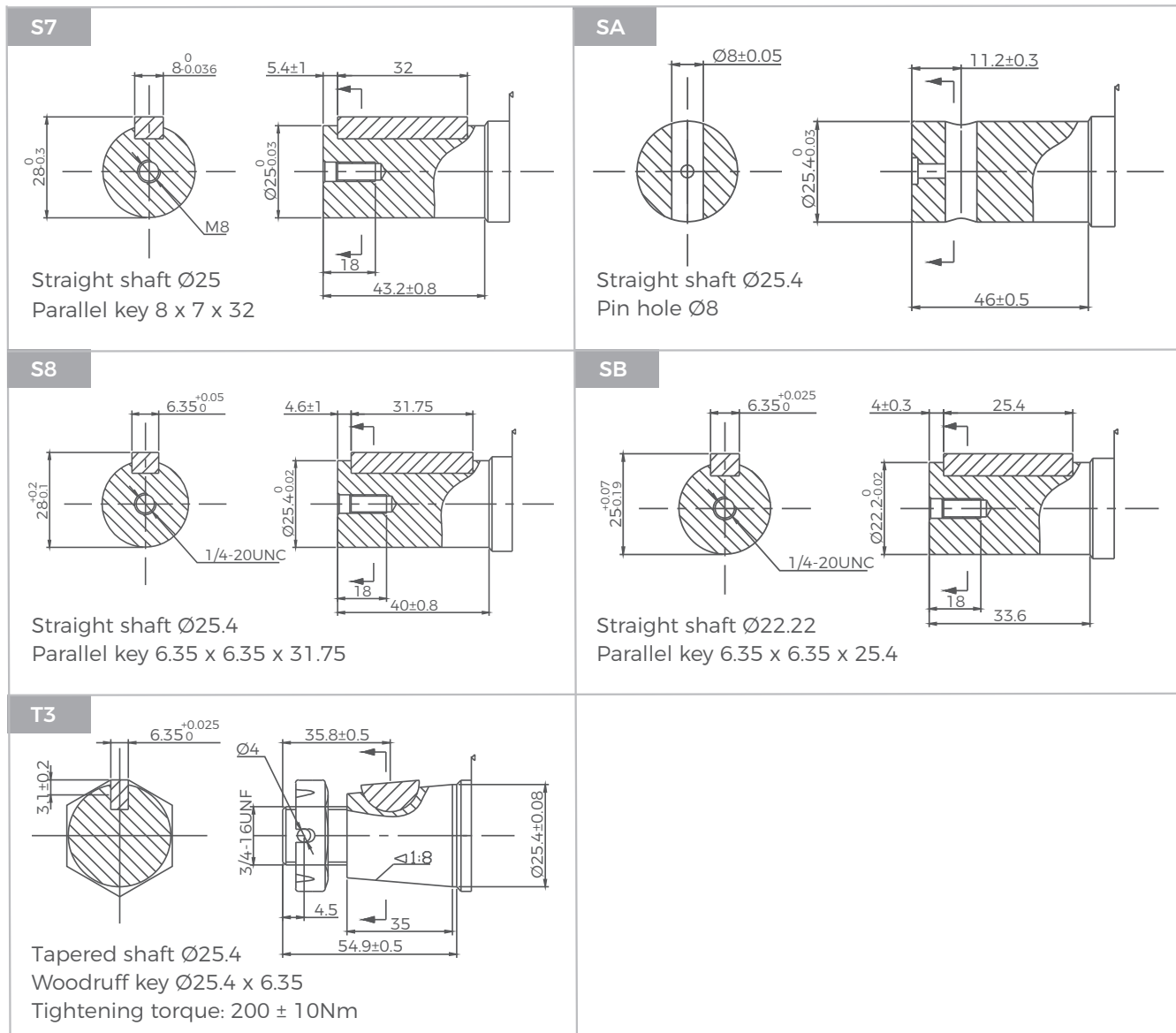

GRS Series Hydraulic Motors

Permissible shaft seal pressure

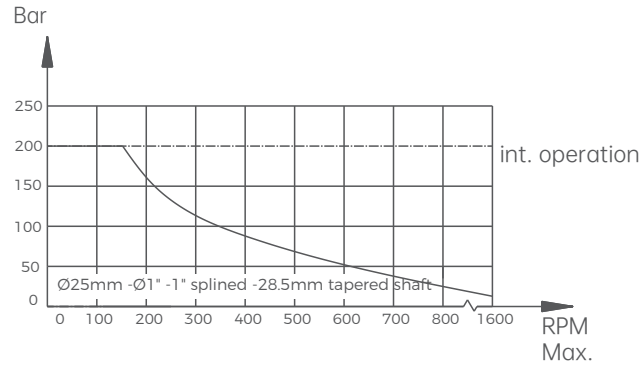

Drain Port

In applications without drain line, output shaft seal exceeds a bit of the pressure in the return line. When applications use the drain line, the pressure of output shaft seal equals the pressure in drain line.

Standard direction of shaft rotation: Standard

When facing shaft end of motor, shaft to rotate:
Clockwise when port "A" is pressurized.
Counter-clockwise port "B" is pressurized.

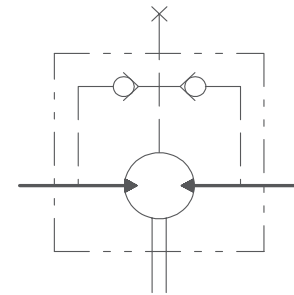

GRS with standard shaft seal, check valves and without use of drain connection: The pressure on the shaft seal never exceeds the pressure in the return line.
GRS with standard shaft seal, check valves and with drain connection: The shaft seal pressure equals the pressure on the drain line.

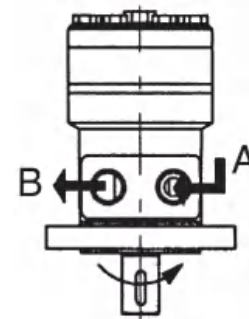

Output shaft axial and radial force

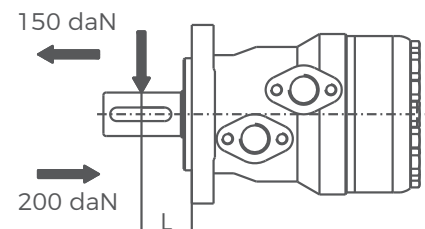
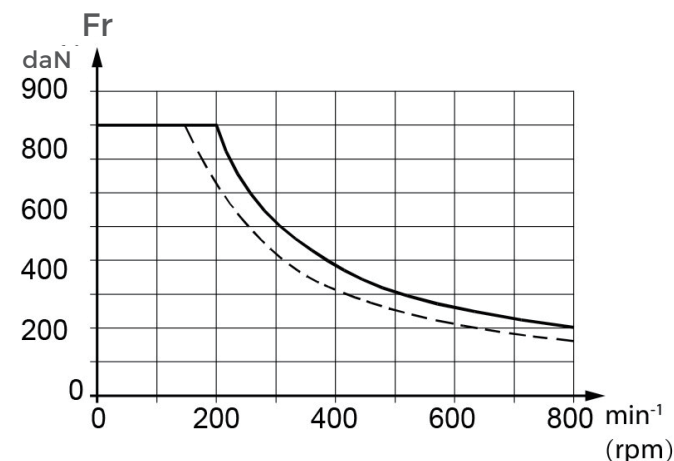

$$Fr = \frac{800}{n} * \frac{25000}{95 + L} \text{ (daN)}$$

Fr = Radial Force (daN)

L = Distance (mm)

n = Speed (rpm)

Rhomb-flange L = 30mm

Square-flange L = 24mm



GH Series Hydraulic Motors

Options

- Flange connection
- Straight, splined and tapered shafts
- Metric and BSPP ports
- Other special features

Applications

- Conveyors
- Feeding equipment of robots and manipulators
- Metal working machines
- Textile machines
- Agricultural machines
- Food industries
- Mining machines



General

Max. Displacement	cm ³ /rev [in ³ /rev]	502,4 [30.7]
Max. Speed	RPM	445
Max. Torque	daNm [lb-in]	cont.: 84 [7434] int.: 104 [9204]
Max. Output	kW [HP]	18,5 [24.8]
Max. Pressure Drop	bar [PSI]	cont.: 175 [2540] int.: 200 [2900]
Max. Oil Flow	lpm [GPM]	90 [23.78]
Min. Speed	RPM	5
Pressure fluid		Mineral based- HLP (DIN 51524) or HM (ISO 6743/4)
Temperature Range	°C [°F]	-40-140 [-104-284]
Optimal Viscosity range	mm ³ /s [SUS]	20-75 [98-347]
Filtration	GH	ISO code: 20/16 (Min. recommended fluid filtration of 25 microns)

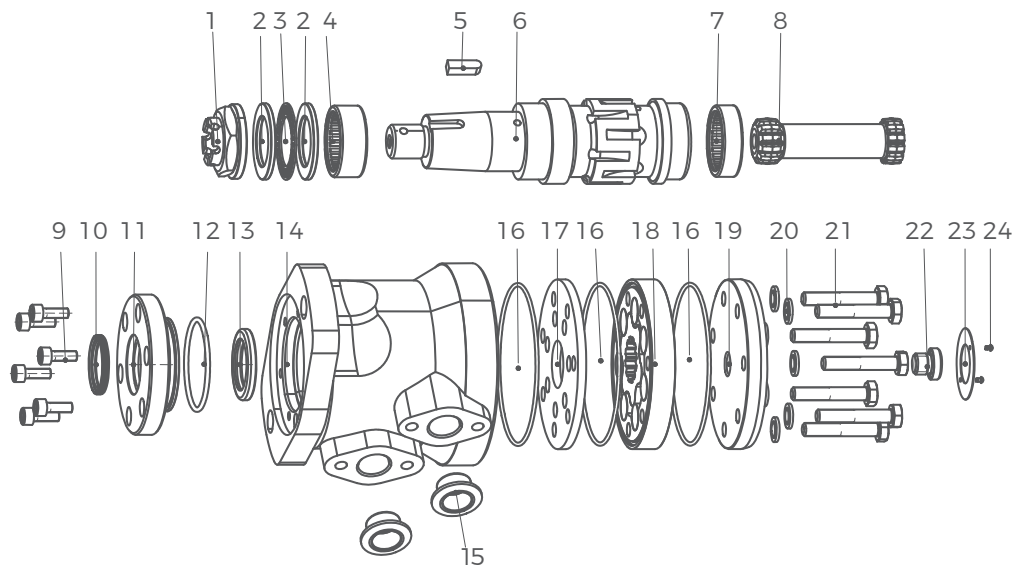

- 1 Slotted nuts
- 2 Bearing retainer
- 3 Thrust needle roller bearing
- 4 Needle roller bearings
- 5 Parallel Key
- 6 Output shaft

- 7 Thrust needle roller bearing
- 8 Transmission shaft
- 9 Screw
- 10 Skeleton anti-dust ring
- 11 Front cover
- 12 O-ring

- 13 Pressure Resistant Oil Seal
- 14 Housing
- 15 Oil port plug cap
- 16 O-ring
- 17 Spacer
- 18 Rotor and stator

- 19 Rear cover
- 20 Washer
- 21 Rear cover bolts
- 22 Plug
- 23 Nameplate
- 24 Rivets



Specifications

Type		GH200	GH250	GH315	GH400	GH500
Displacement, cm ³ /rev [in ³ /rev]		201.3[12.3]	252[15.4]	314.9[19.2]	396.8[24.2]	502.4[30.7]
Max. Speed,	Cont.	370	295	235	185	150
RPM	Int.*	445	350	285	225	180
Max. Torque	Cont.	514510]	61[5398]	74[6548]	84[7434]	82[7257]
daNm [lb-in]	Int.*	58[5130]	70[6195]	82[7257]	98[8673]	104[9204]
	Peak**	64[5064]	79[6992]	98[8673]	109[9647]	117[10350]
Max. Output	Cont.	16[21]	16[21]	14[18.7]	12.5[16.7]	11[14.7]
kW [HP]	Int.*	18.5[24.8]	18.5[24.8]	15.5[20.7]	15[20.1]	14[18.7]
Max. Pressure Drop	Cont.	175[2540]	175[2540]	175[2540]	155[2240]	125[1810]
bar [PSI]	Int.*	200[2900]	200[2900]	200[2900]	190[2750]	160[2320]
	Peak**	225[3260]	225[3260]	225[3260]	210[3045]	180[2610]
Max. Oil Flow	Cont.	75[19.81]	75[19.81]	75[19.81]	75[19.81]	75[19.81]
lpm [GPM]	Int.*	90[23.78]	90[23.78]	90[23.78]	90[23.78]	90[23.78]
Max. Inlet Pressure	Cont.	200[2900]	200[2900]	200[2900]	200[2900]	200[2900]
bar [PSI]	Int.*	225[3260]	225[3260]	225[3260]	225[3260]	225[3260]
	Peak**	250[3626]	250[3626]	250[3626]	250[3626]	250[3626]
Max. Starting Pressure with Unloaded Shaft, bar [PSI]		5[72]	5[72]	5[72]	5[72]	5[72]
Min. Starting Torque	At max. press. drop Cont.	39[3450]	52[4600]	66[5840]	72[6370]	72[6370]
daNm [lb-in]	At max. press. drop Int.*	45[3980]	59[5221]	73[6460]	88[7788]	88[7788]
Min. Speed, RPM		10	10	8	5	5
Weight, kg [lb]	GH	10.5[23.2]	11[24.3]	11.5[25.4]	12.3[27.1]	13[28.7]



Function Diagrams

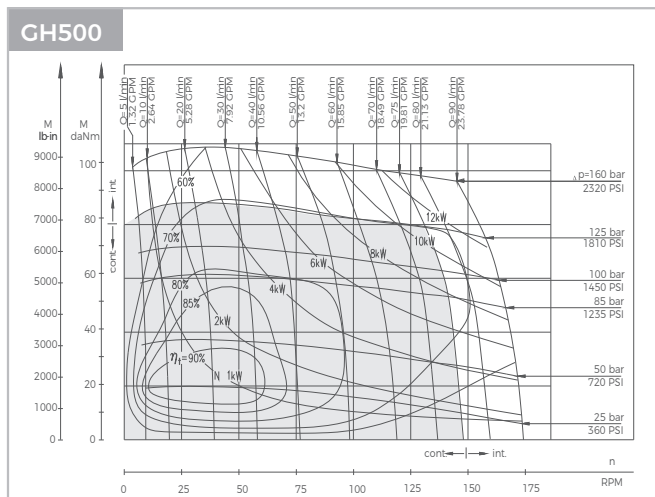
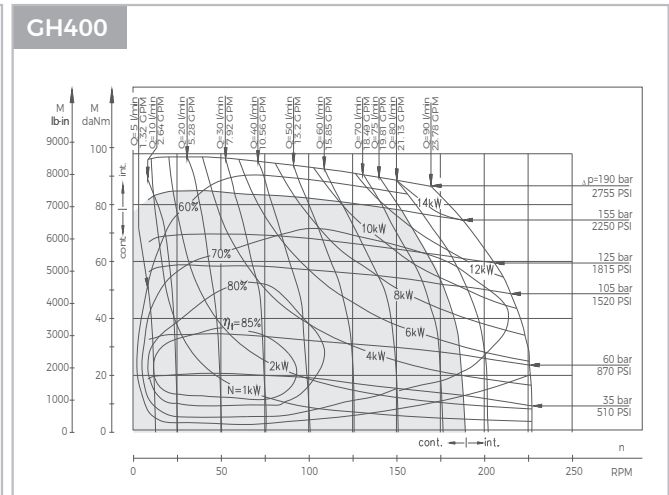
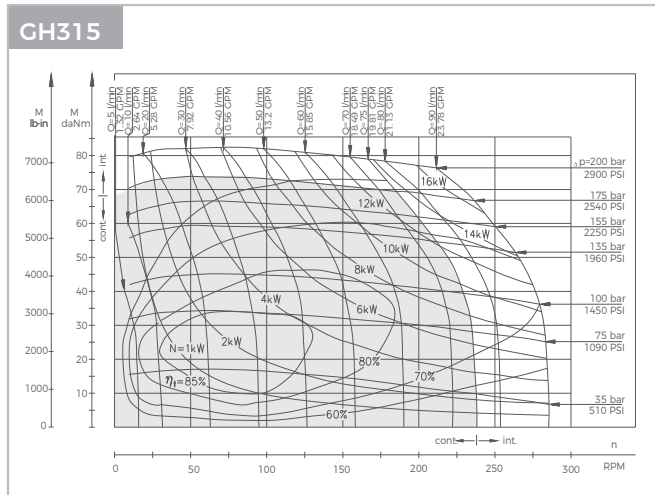
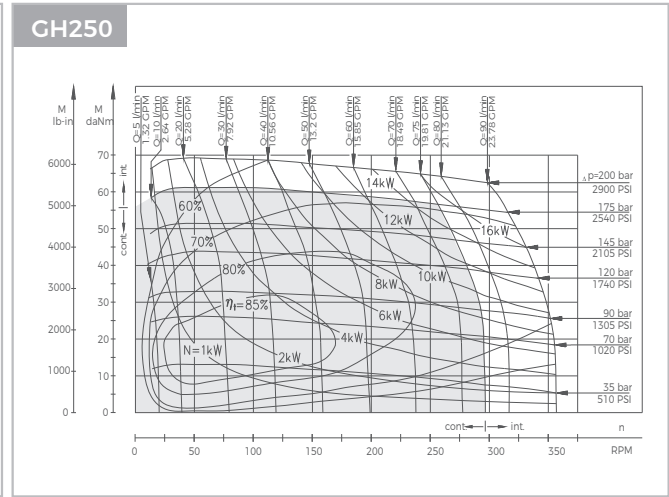
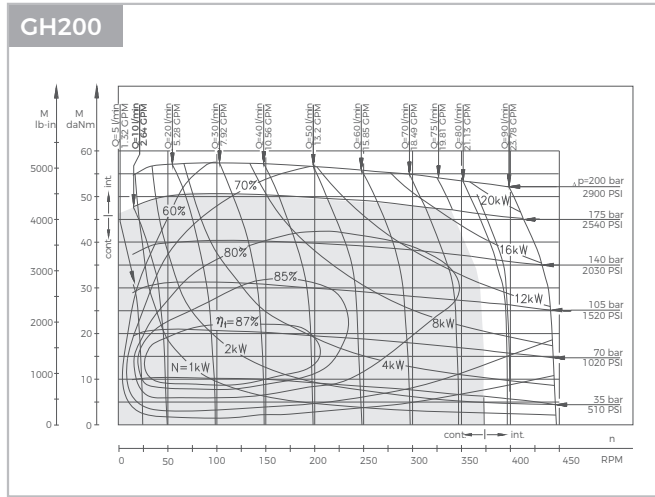

The function diagrams data is for average performance of randomly selected motors at backpressure. 5–10 bar [72.5–145 PSI] and oil with viscosity of 32 mm²/s [150 SUS] at 50°C [122°F].

GH Dimensions and Mountings

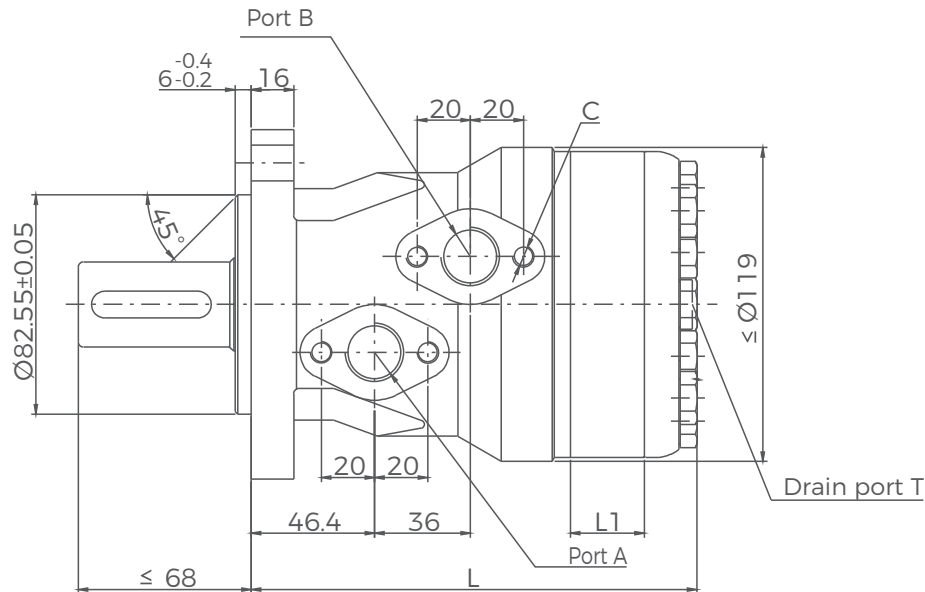

Model	L(mm)	L1(mm)
GH200	168	27
GH250	175	34
GH315	184	42
GH400	195	54
GH500	206	65

Mounting	G1 (depth)	M1 (depth)	U2 (depth)	U1 (depth)	G2 (depth)
P(A, B)	G1/2(15)	M22 x1.5(15)	7/8-14 O-ring(17)	1/2-14 NPTF(15)	PT(RC)1/2(15)
T	4-M8(13)	4-M8(13)	4-5/16-18 UNC(13)	4-5/16-18 UNC(13)	4-M8(13)
C	G1/4(12)	M14 x 1.5(12)	7/16-20 UNF(12)	7/16-20 UNF(12)	PT(RC)1/4(9.7)



GH Flange Covers Dimensions

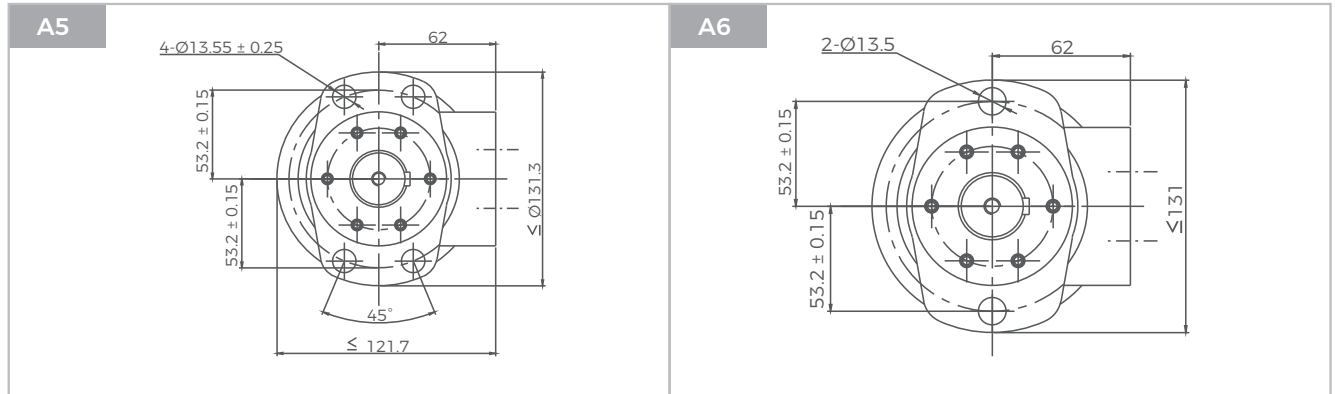

GH Shafts Dimensions

<p>S4</p> <p>Straight shaft $\varnothing 32$ Parallel key 10 x 8 x 45</p>	<p>SF</p> <p>Straight shaft $\varnothing 35$ Parallel key 10 x 8 x 45</p>
<p>SG</p> <p>Straight shaft $\varnothing 31.75$ Parallel key 7.96 x 7.96 x 31.75</p>	<p>R4</p> <p>Splined shaft SAE 6B</p>
<p>R3</p> <p>Splined shaft 14-DP 12/24</p>	<p>R6</p> <p>Splined shaft 14-DP 12/24</p>
<p>T4</p> <p>Tapered shaft $\varnothing 35$ Parallel key B6 x 6 x 20 Tightening torque: 200 ± 10Nm</p>	<p>SH</p> <p>Straight shaft $\varnothing 35$ Parallel key 10 x 8 x 45</p>

GH Series Hydraulic Motors

Permissible shaft seal pressure

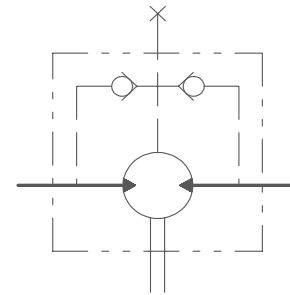
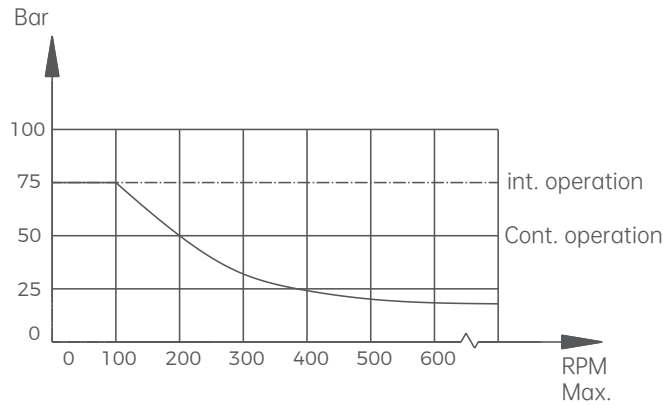

GH with standard shaft seal check valves and without use of drain connection: The pressure on the shaft seal never exceeds the pressure in the return line.

GH with standard shaft seal, check valves and with drain connection: The shaft seal pressure equals the pressure on the drain line.

Drain Port

In applications without drain line, output shaft seal exceeds a bit of the pressure in the return line. In applications using the drain line, the pressure of output shaft seal equals the pressure in drain line.

Standard direction of shaft rotation: Standard

When facing shaft end of motor, shaft to rotate:
Clockwise. When port A is pressurized.
Counter-clockwise port B is pressurized.

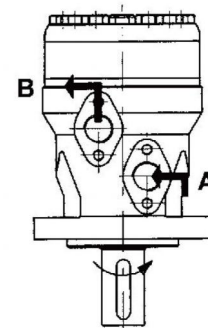

Axial and radial force

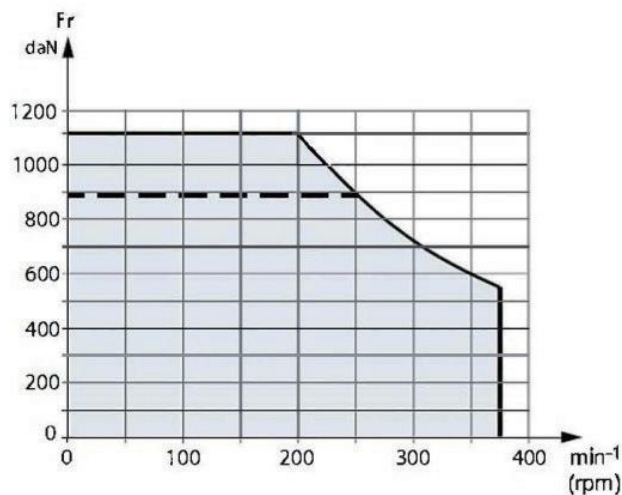

The drawing shows the permissible radial load when L= 30mm [1.18 in].

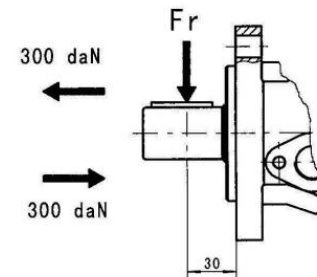

$$Fr = \frac{1100}{n} * \frac{25000}{103.5 + L} \text{ (daN)}$$

Fr = Radial Force (daN)

L = Distance (mm)

n = Speed (rpm)

GS Series Hydraulic Motors

Options

- Flange and wheel mount
- Bearingless motor
- Motor with brake
- Tachometer connection
- Speed sensing
- Side and rear ports
- Straight, splined and tapered shafts
- Shaft seal for high and low pressure
- Metric and BSPP ports
- Other special features

Applications

- Conveyors
- Road building machines
- Metal working machines
- Special vehicles
- Agricultural machines
- Food industries
- Mining machines







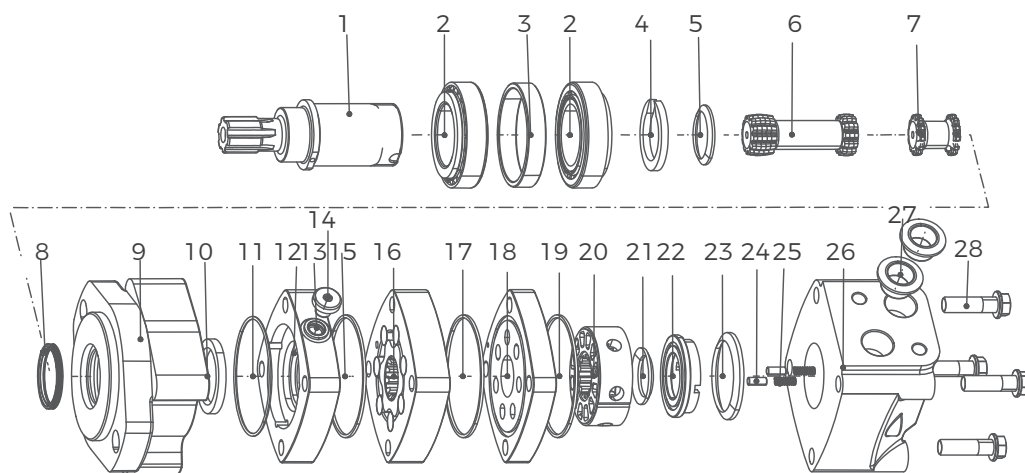

















General

Max. Displacement	cm ³ /rev [in ³ /rev]	564.9 [34.47]
Max. Speed	RPM	1000
Max. Torque	daNm [lb-in]	cont.: 85 [7520] int.: 99 [8760]
Max. Output	kW [HP]	23 [30.8]
Max. Pressure Drop	bar [PSI]	cont.: 210 [3050] int.: 275 [3990]
Max. Oil Flow	lpm [GPM]	90 [24]
Min. Speed	RPM	5
Permissible Shaft Loads	daNm [lbs]	Pa=500 [1125]
Pressure fluid		Mineral based- HLP (DIN 51524) or HM (ISO 6743/4)
Temperature Range	°C [°F]	-40-140 [-104-284]
Optimal Viscosity range	mm ² /s [SUS]	20-75 [98-347]
Filtration	GS	ISO code 20/16 (Min. recommended fluid filtration of 25 microns)



- | | | | |
|--------------------------|--------------------|----------------------------|------------------------|
| 1 Output shaft | 8 Anti-dust ring | 15 O-ring | 22 Flow pressure plate |
| 2 Tapered roller bearing | 9 Front cover | 16 Rotor and stator | 23 Special shape ring |
| 3 Bearing outer retainer | 10 Shaft seal | 17 Special shape ring | 24 Positioning pins |
| 4 Washers | 11 O-ring | 18 Balance plate | 25 Spring |
| 5 Special shape ring | 12 Connecting body | 19 Special shape ring | 26 Rear housing |
| 6 Transmission shaft | 13 Sealing gasket | 20 Flow distribution plate | 27 Oil port plug cap |
| 7 Coupling shaft | 14 Plug | 21 Special shape ring | 28 Screw |

Ordering Code

GS SERIES		DISP	FLANGE	SHAFT	PORTS	ROTATION	PAINT	FUNCTION	
CODE	TYPE	CODE	FLANGE	CODE	SHAFT	CODE	ROTATION		
GS	Orbital motor		A7 2-Ø13.5 SAE A Ø106.4, pilot Ø82.5×6.3 	C1 Cardan 12-DP 12/24 	A Standard				
GSS	Bearingless motor		H3 4-Ø13.5 square Ø106.4, pilot Ø82.5×6.3 	S4 Ø32 parallel key 10×8×45 	R Opposite				
			A9 6-Ø13.5 SAE A Ø106.4, pilot Ø82.5×2.6 	S8 Ø25.4 parallel key 6.35×6.35×25.4 					
CODE	DISP cm ³ /rev [in ³ /rev]		W1 4-Ø13.5 wheel Ø160, pilot Ø125×8 	SC Ø31.75 parallel key 7.96×7.96×31.75 		CODE	PAINT		
80	80.5 [4.9]		AA 2-Ø14.3 SAE B Ø146.05, pilot Ø101.6×9.4 	R2 Ø31.75 splined tooth 14-DP 12/24 		A	No paint		
100	100 [6.1]		H1 4-Ø11.5 square Ø106.4, pilot Ø82.5×6.3 	R3 Long Ø31.75 splined tooth 14-DP 12/24 		B	Blue		
125	125.7 [7.67]		B1 4-Ø11 circle Ø125, pilot Ø100×6 	R7 Ø34.85 splined tooth 6-34.85×28.14×8.64 		C	Black		
160	159.7 [9.7]		H2 4-Ø13.5 square Ø127, pilot Ø101.6×6.3 	T4 Tapered Ø35 parallel key B6×6×20 		S	Silver grey		
200	200 [12.2]			T5 Tapered Ø31.75 parallel key 7.96×7.96×31.75 					
250	250 [15.3]			R8 Ø25.4 splined tooth SAE 6B 					
315	314.9 [19.2]			R5 Ø22 splined tooth 13-DP16/32 					
400	397 [24.2]			S1 Ø25 parallel key 8×7×32 					
475	474.6 [28.96]			S6 Ø25.4 parallel key Ø25.4×6.35 					
525	522.7 [31.88]			T2 Tapered Ø35 parallel key 7.96×7.96×25.4 					
565	564.9 [34.47]								
				CODE	PORTS			CODE	FUNCTION
				G9	G1/2, G1/4 manifold 2×M10			A	Standard
				M8	M22×1.5, M14×1.5 manifold 2×M10			N	Big radial force
				UB	7/8-14UNF O-ring, 7/16-20UNC manifold 2×3/8-16UNC			D	No case drain
				UC	1/2-14 NPTF, 7/16-20UNF manifold 2×3/8-16UNC			F	Free running
								L	Low speed
								V	High temp
								S	Low temp



Specifications

Type		GS80	GS100	GS125	GS160	GS200	GS250
Displacement, cm ³ /rev [in ³ /rev]		80,5[4.91]	100[6.1]	125,7[7.67]	159,7[9.74]	200[12.2]	250 [15.3]
Max. Speed	Cont.	810	750	600	470	375	300
RPM	Int*	1000	900	720	560	450	360
Max. Torque	Cont.	24[2120]	30,5[2700]	37,5[3320]	49[4340]	61[5400]	72[6370]
daNm [lb-in]	Int*	31[2740]	39[3450]	49[4340]	60[5310]	72[6370]	87[7700]
Max. Output	Cont.	15,5[20.8]	18[24.1]	18[24.1]	16,5[22.1]	16,5[22.1]	14,5[19.4]
kW [HP]	Int*	19,5[26.2]	22,8[30.2]	22,5[30.2]	23[30.8]	22[29.52]	18[24.1]
Max. Pressure Drop	Cont.	210[3050]	210[3050]	210[3050]	210[3050]	210[3050]	200[2900]
bar [PSI]	Int*	275[3990]	275[3990]	275[3990]	275[3990]	275[3990]	250[3630]
	Peak**	295[4280]	295[4280]	295[4280]	295[4280]	295[4280]	270[3920]
Max. Oil Flow	Cont.	65[17]	75[20]	75[20]	75[20]	75[20]	75[20]
lpm [GPM]	Int*	80[21]	90[24]	90[24]	90[24]	90[24]	90[24]
Max. Inlet Pressure	Cont.	230[3340]	230[3340]	230[3340]	230[3340]	230[3340]	230[3340]
bar [PSI]	Int*	295[4280]	295[4280]	295[4280]	295[4280]	295[4280]	295[4280]
	Peak**	300[4350]	300[4350]	300[4350]	300[4350]	300[4350]	300[4350]
Max. Return Pressure	Cont.	140[2030]	140[2030]	140[2030]	140[2030]	140[2030]	140[2030]
with Drain Line	Int*	175[2540]	175[2540]	175[2540]	175[2540]	175[2540]	175[2540]
bar [PSI]	Peak**	210[3050]	210[3050]	210[3050]	210[3050]	210[3050]	210[3050]
Max. Starting Pressure with Unloaded Shaft, bar [PSI]		12[175]	10[145]	10[145]	8[115]	8[115]	8[115]
Min. Starting Torque	At max. press. drop Cont.	18[1590]	23[2040]	29[2570]	37[3270]	47[4160]	56[4960]
daNm [lb-in]	At max. press. drop Int*	23,5[2080]	30[2660]	38[3360]	46[4070]	56[4960]	70[6200]
Min. Speed, RPM		10	10	8	8	6	6
Weight, kg [lb]	GS	9,9[21.8]	10,1[22.2]	10,4[22.9]	10,8[23.8]	11,2[24.7]	11,7[25.8]
For rear port + 0,40 [.88]	GSS	7,9[17.4]	8,1[17.8]	8,4[18.5]	8,8[19.4]	9,2[20.2]	9,7[21.4]

Specifications

Type		GS315	GS400	GS475	GS525	GS565
Displacement, cm ³ /rev [in ³ /rev]		314.9[19.2]	397[24.2]	474.6[28.96]	522.7[31.88]	564.9[34.47]
Max. Speed	Cont	240	190	160	145	130
RPM	Int*	290	230	190	175	160
Max. Torque	Cont	82.5[7300]	86.5 [7660]	85[7520]	85[7520]	85[7520]
daNm [lb-in]	Int*	100[8850]	99[8760]	99[8760]	99[8760]	99[8760]
Max. Output	Cont	15[20.1]	11[14.8]	8.4[11]	7.6[10.2]	6.9[9]
kW [HP]	Int*	17[22.8]	12.5[16.8]	11.3[15]	10.4[13.9]	9.6[13]
Max. Pressure Drop	Cont	200[2900]	160[2320]	130[1880]	115[1670]	105[1520]
bar [PSI]	Int*	240[3480]	190[2760]	150[2180]	135[1960]	125[1810]
	Peak**	260[3770]	210[3050]	170[2470]	155[2250]	145[2100]
Max. Oil Flow	Cont	75[20]	75[20]	75[20]	75[20]	75[20]
lpm [GPM]	Int*	90[24]	90[24]	90[24]	90[24]	90[24]
Max. Inlet Pressure	Cont	230[3340]	230[3340]	230[3340]	230[3340]	230[3340]
bar [PSI]	Int*	295[4280]	295[4280]	295[4280]	295[4280]	295[4280]
	Peak**	300[4350]	300[4350]	300[4350]	300[4350]	300[4350]
Max. Return Pressure	Cont	140[2030]	140[2030]	140[2030]	140[2030]	140[2030]
with Drain Line	Int*	175[2540]	175[2540]	175[2540]	175[2540]	175[2540]
bar [PSI]	Peak**	210[3050]	210[3050]	210[3050]	210[3050]	210[3050]
Max. Starting Pressure with Unloaded Shaft, bar [PSI]		8[115]	8[115]	8[115]	8[115]	8[115]
Min. Starting Torque	At max. press. drop Cont.	71[6280]	71[6280]	71[6280]	71[6280]	71[6280]
daNm [lb-in]	At max. press. drop Int*	85[7520]	84[7430]	84[7430]	84[7430]	84[7430]
Min. Speed, RPM		5	5	5	5	5
Weight, kg [lb]	GS	12.4[27.3]	13.1[29.3]	14.1[31]	14.6[32.2]	15[33.1]
For rear port + 0.40 [.88]	GSS	10.4[22.9]	11.3[24.9]	12.1[26.7]	12.6[27.8]	13[28.6]

Function Diagrams

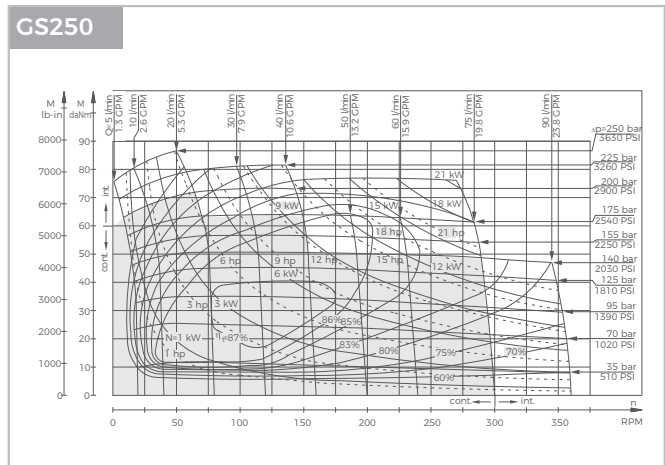
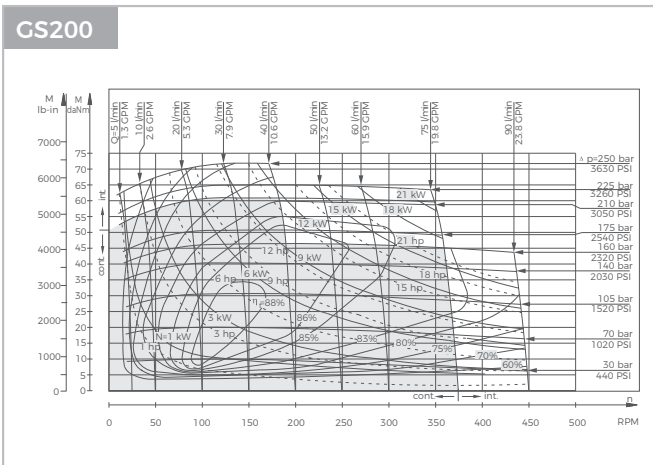
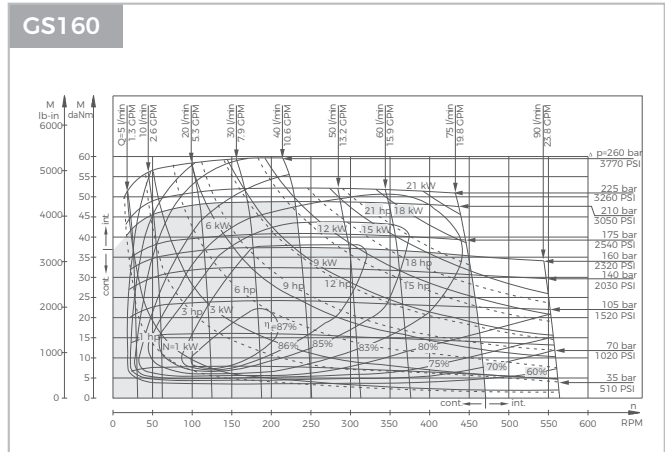
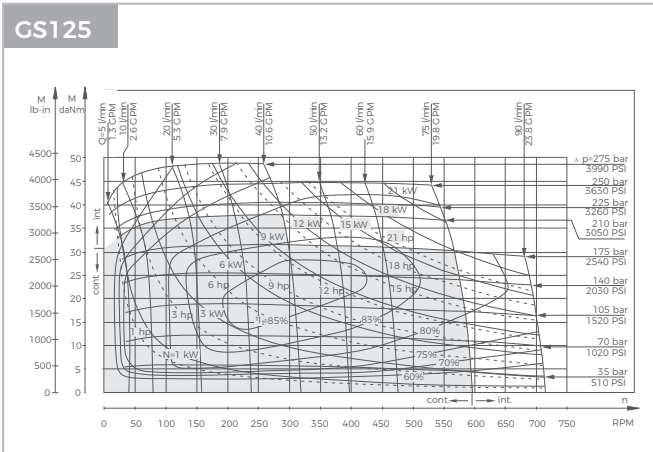
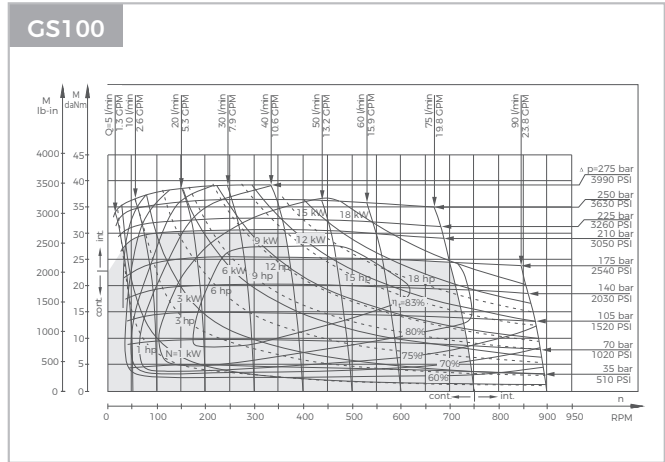
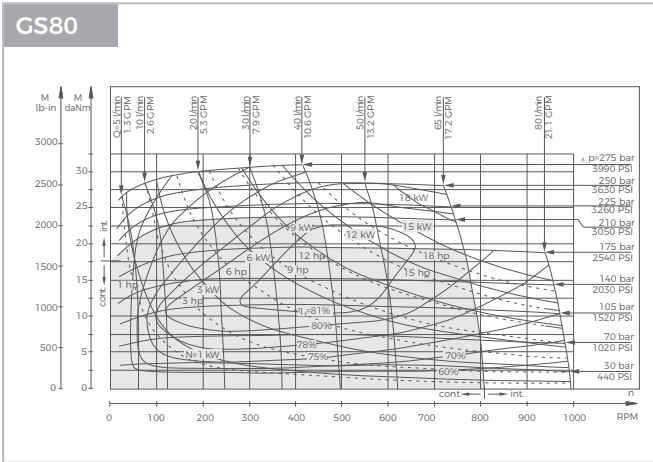

The function diagrams data is for average performance of randomly selected motors at backpressure. 5–10 bar [72.5–145 PSI] and oil with viscosity of 32 mm²/s [150 SUS] at 50°C [122°F].

Function Diagrams

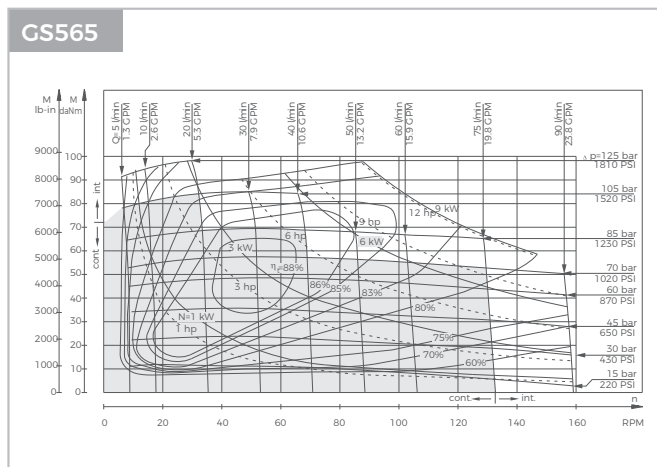
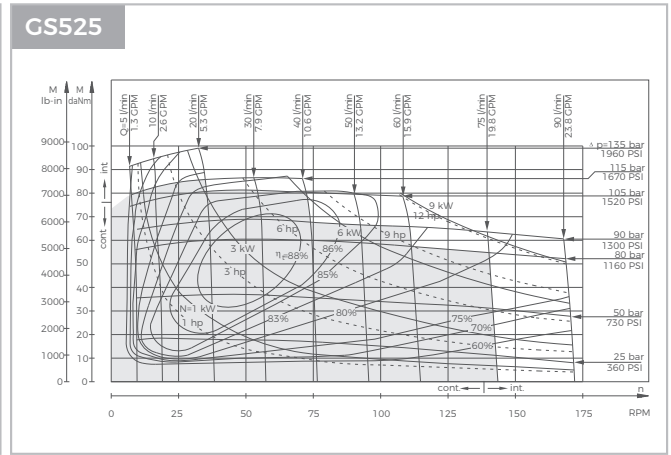
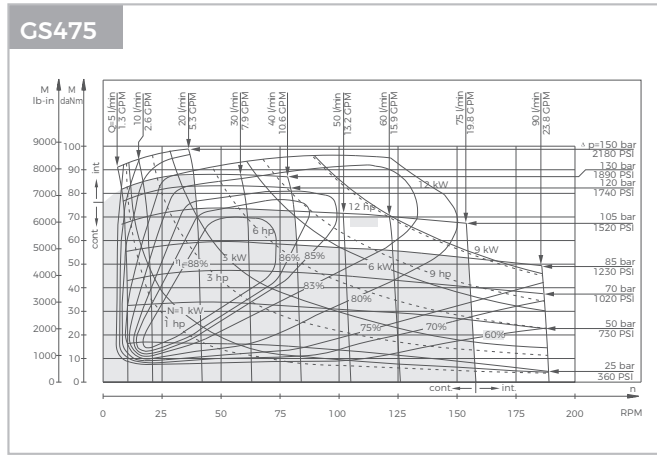
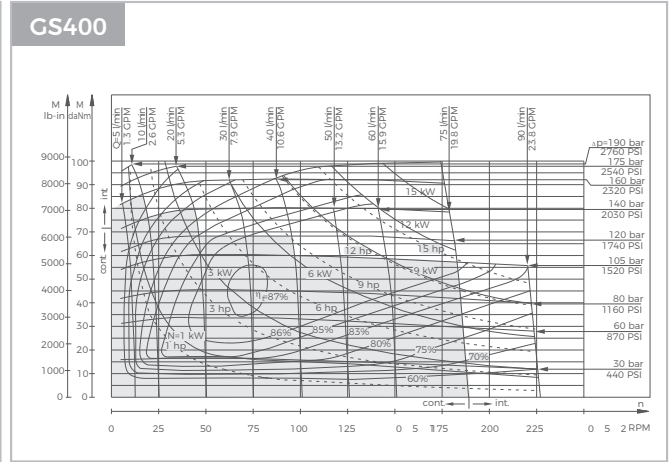
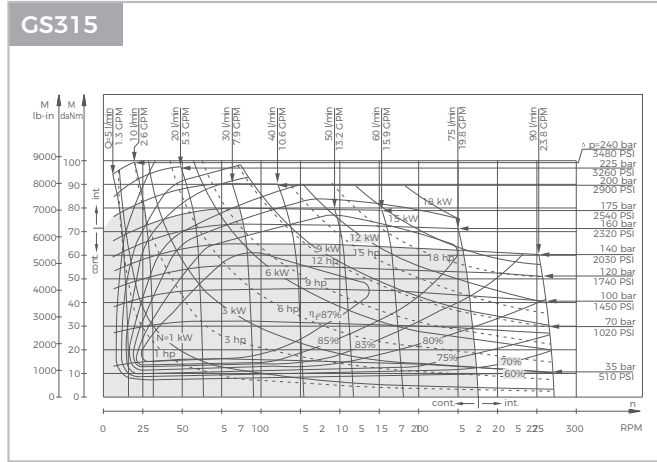

The function diagrams data is for average performance of randomly selected motors at backpressure. 5-10 bar [72.5-145 PSI] and oil with viscosity of 32 mm²/s [150 SUS] at 50°C [122°F].

GS Dimensions and Mountings

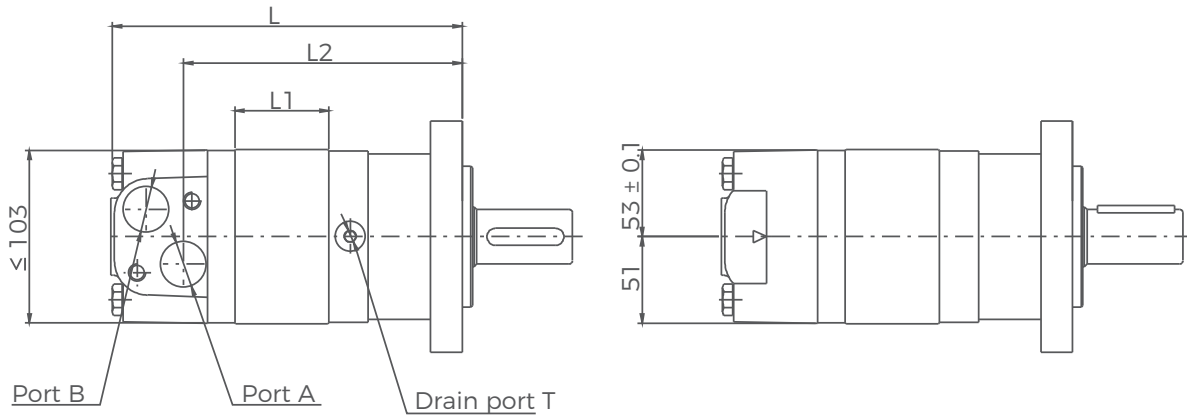

Model	L(mm)	L1(mm)	L2(mm)
GS80	170	16	126.5
GS100	174	20	130.5
GS125	179	25	135.5
GS160	181	27	137.5
GS200	188	34	144.5
GS250	196	42	152.5
GS315	208	54	164.5
GS400	223	69	179.5
GS475	237	83	193.5
GS525	229	75	185
GS565	235	80	191

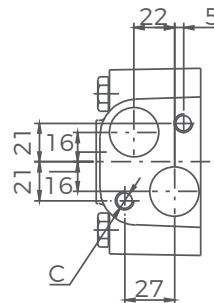

Mounting	G9 (depth)	M8 (depth)	UB (depth)	UC (depth)
P(A,B)	G1/2(15)	M22 x 1.5(15)	7/8-14 O-ring(17)	1/2-14 NPTF(15)
T	G1/4(12)	M14 x 1.5(12)	7/16-20 UNF(12)	7/16-20 UNF(12)
C	2-M10(13)	2-M10(13)	2-3/8-16 UNC(13)	2-3/8-16 UNC(13)

GSS Bearingless Motor Dimensions and Mounting

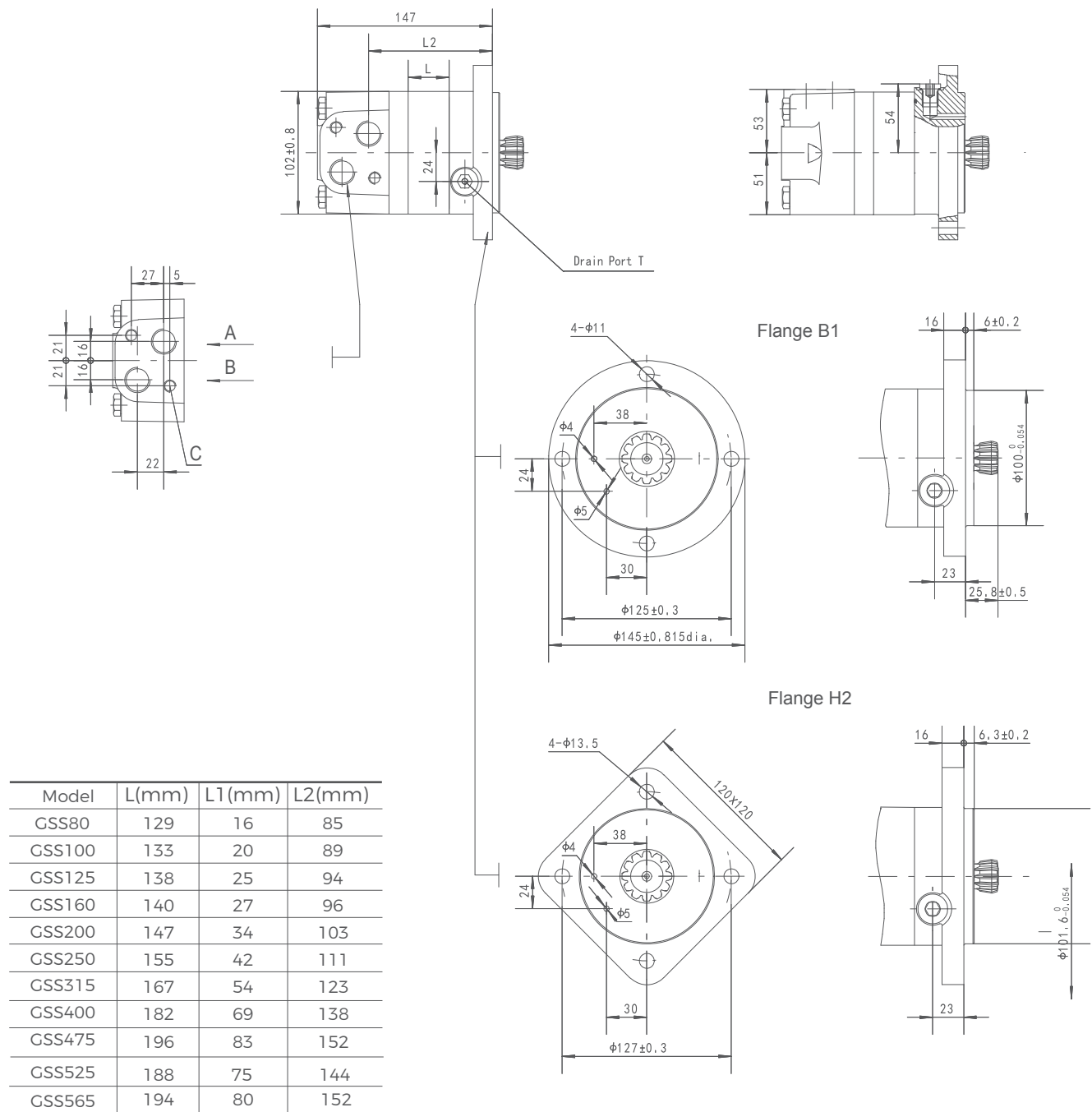

Model	L(mm)	L1(mm)	L2(mm)
GSS80	129	16	85
GSS100	133	20	89
GSS125	138	25	94
GSS160	140	27	96
GSS200	147	34	103
GSS250	155	42	111
GSS315	167	54	123
GSS400	182	69	138
GSS475	196	83	152
GSS525	188	75	144
GSS565	194	80	152

Mounting	G9 (depth)	M8 (depth)	UB (depth)	UC (depth)
P(A, B)	G1/2(15)	M22 x 1.5(15)	7/8-14 O-ring(17)	1/2-14 NPTF(15)
T	G1/4(12)	M14 x 1.5(12)	7/16-20 UNF(12)	7/16-20 UNF(12)
C	2-M10(13)	2-M10(13)	2-3/8-16 UNC(13)	2-3/8-16 UNC(13)

CS Brake Motor-Speed Sensor

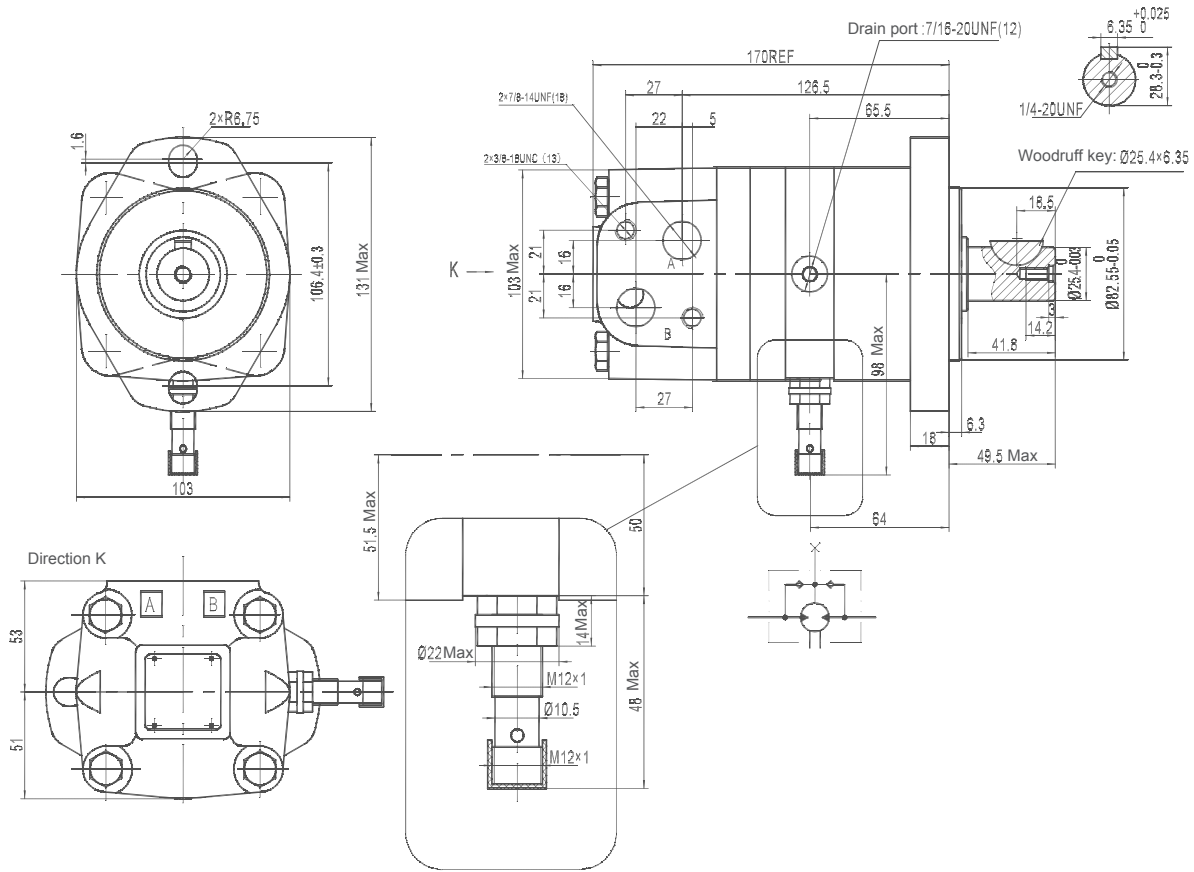

CS Flange Covers Dimensions

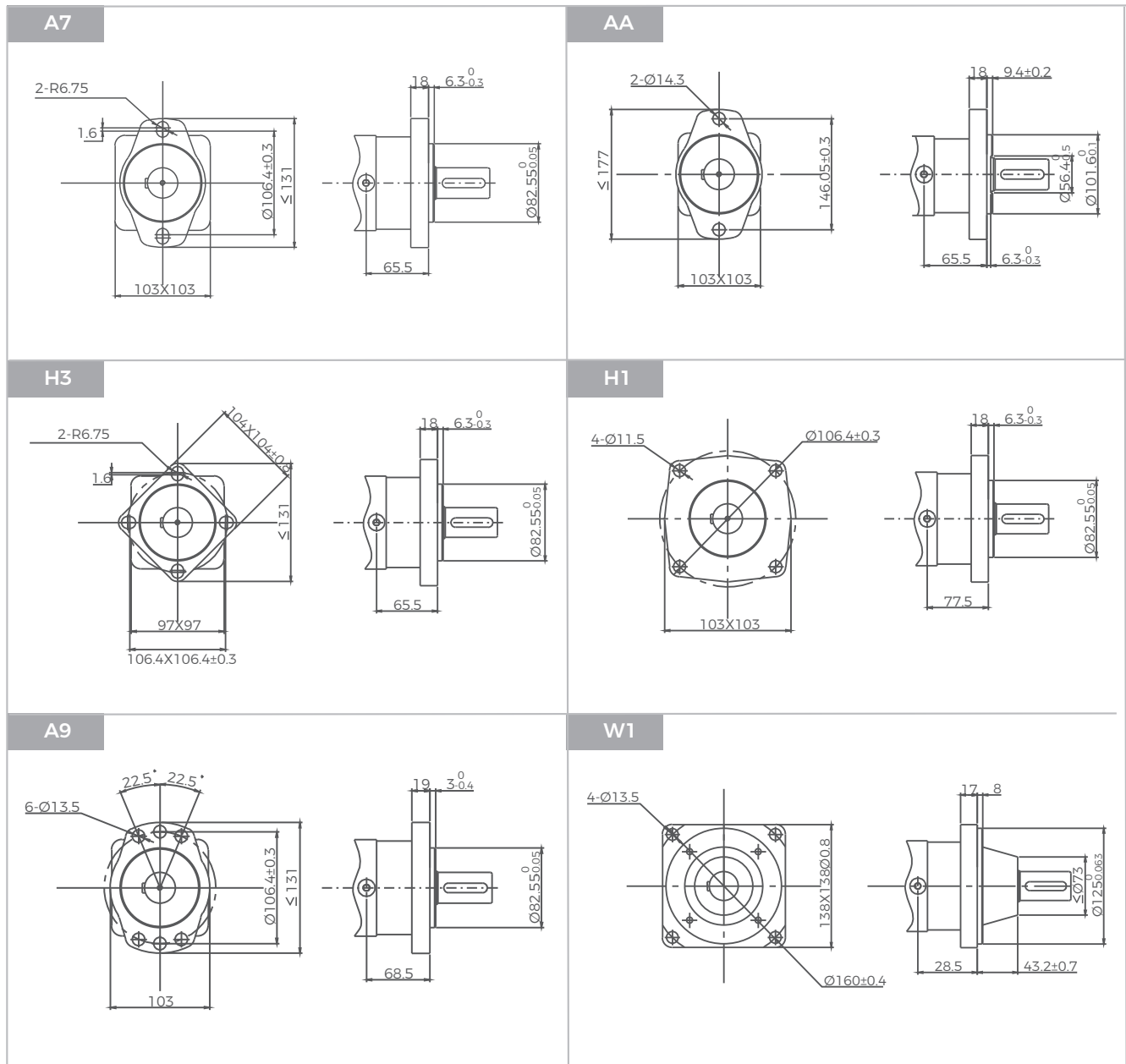

GS Shafts Dimensions

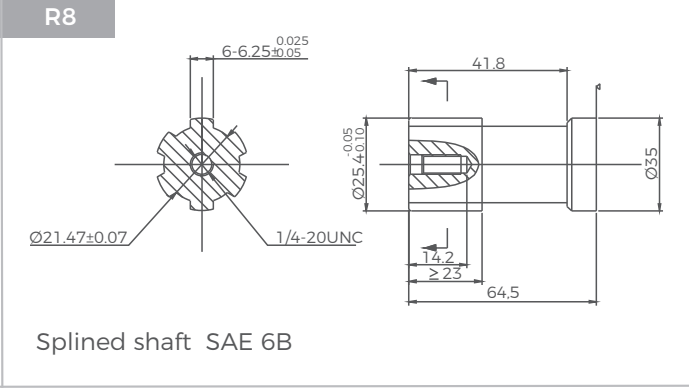
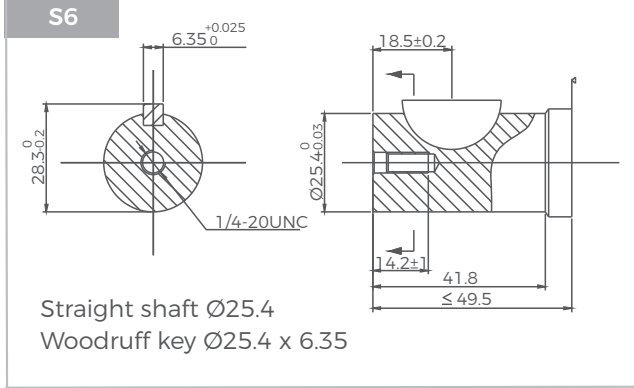
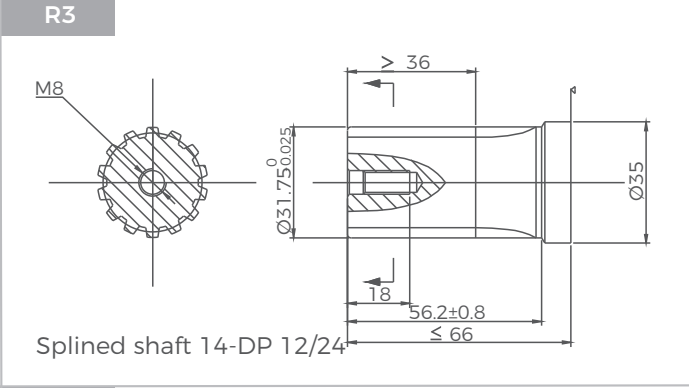
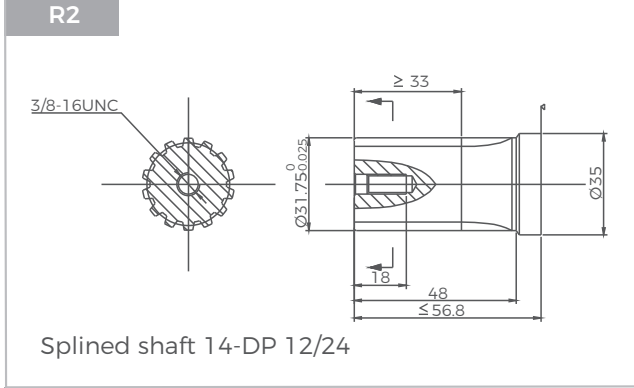
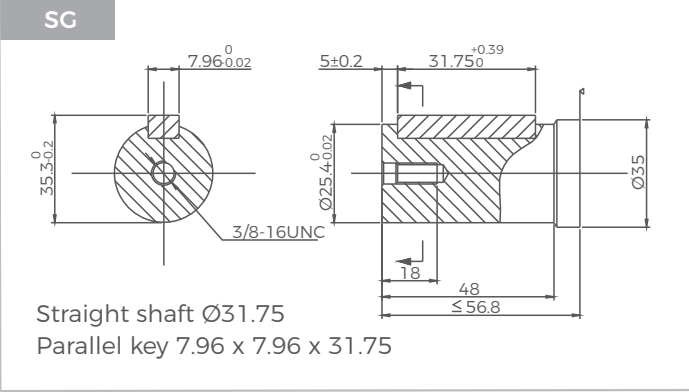
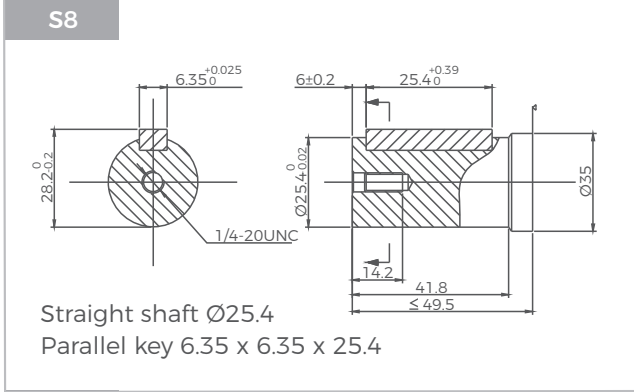
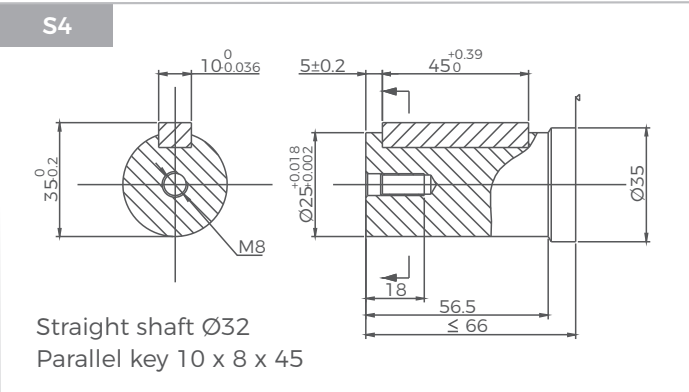
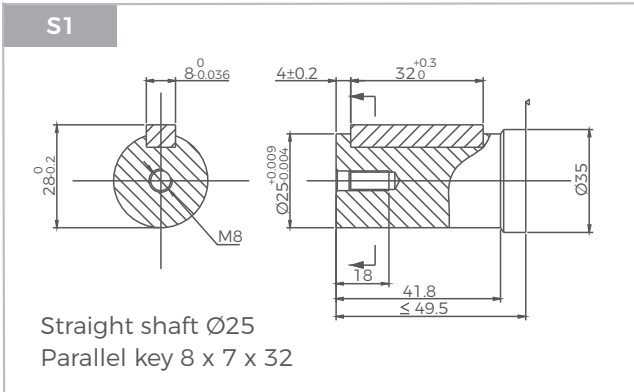

CS Shafts Dimensions

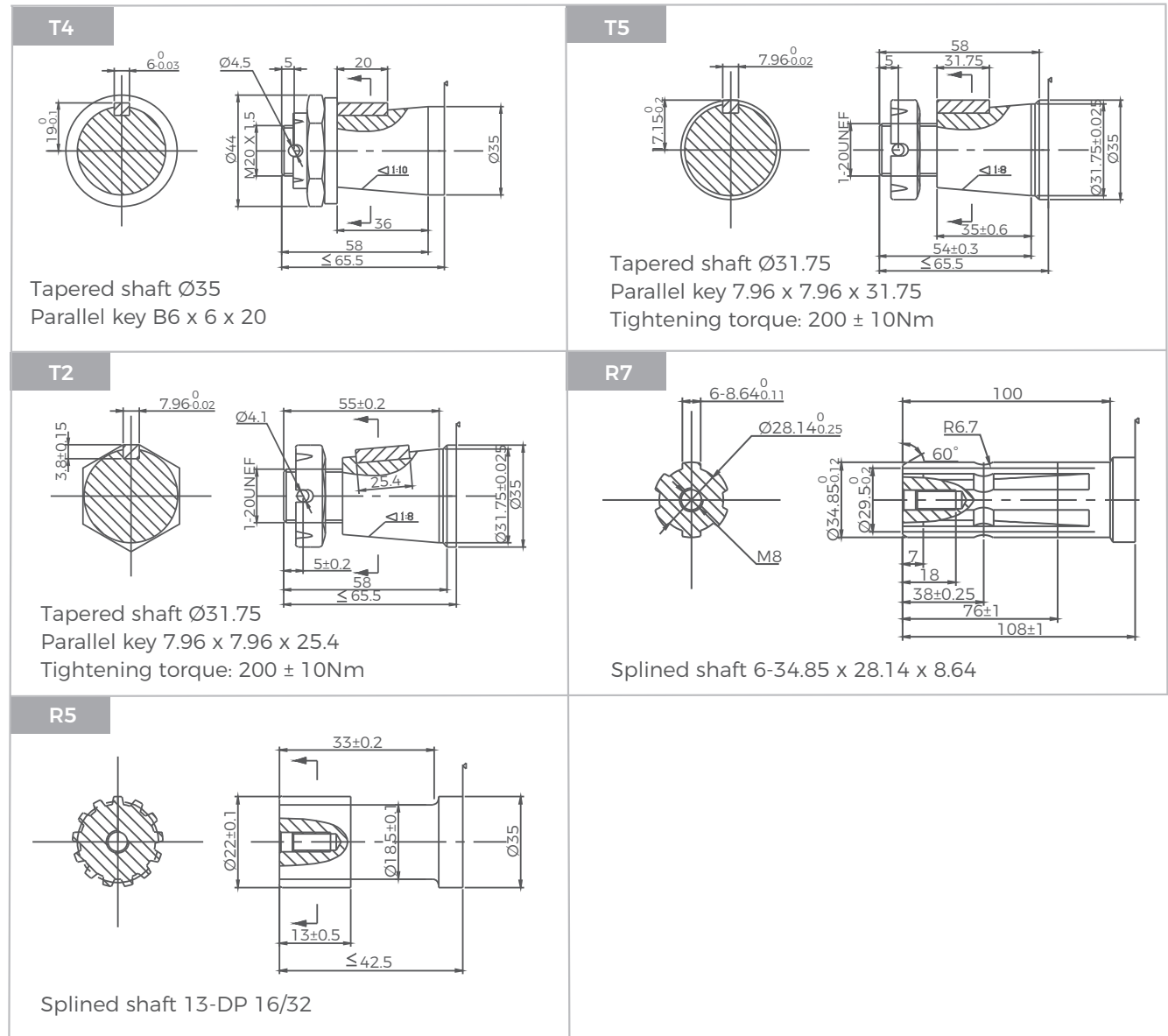

GS Series Hydraulic Motors

Permissible shaft seal pressure

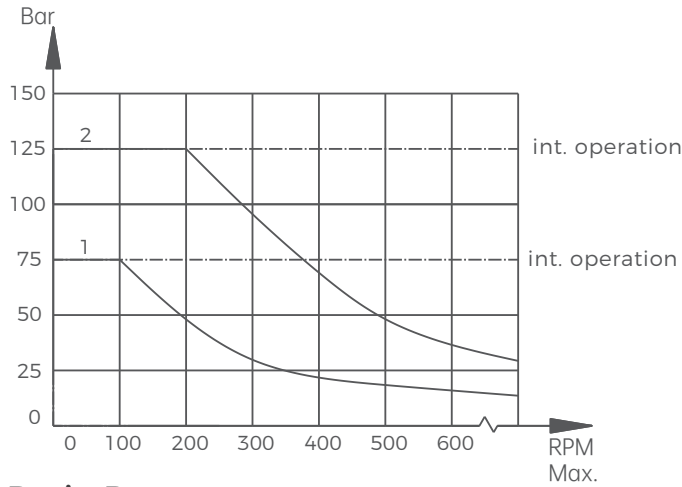

Drain Port

In applications without drain line, output shaft seal exceeds a bit of the pressure in the return line. In applications using the drain line, the pressure of output shaft seal equals the pressure in drain line.

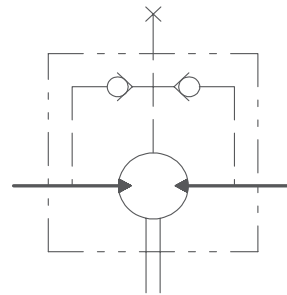

GS with standard shaft seal check valves and without use of drain connection: The pressure on the shaft seal never exceeds the pressure in the return line.

GS with standard shaft seal, check valves and with drain connection: The shaft seal pressure equals the pressure on the drain line.

Standard direction of shaft rotation: Standard

When facing shaft end of motor, shaft to rotate:
Clockwise. When port A is pressurized.
Counter-clockwise port B is pressurized.

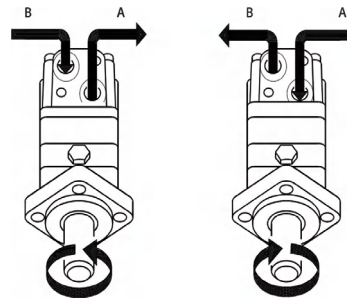

Axial and radial force

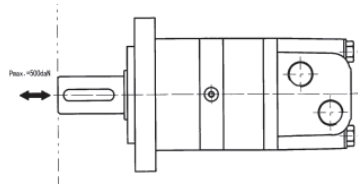
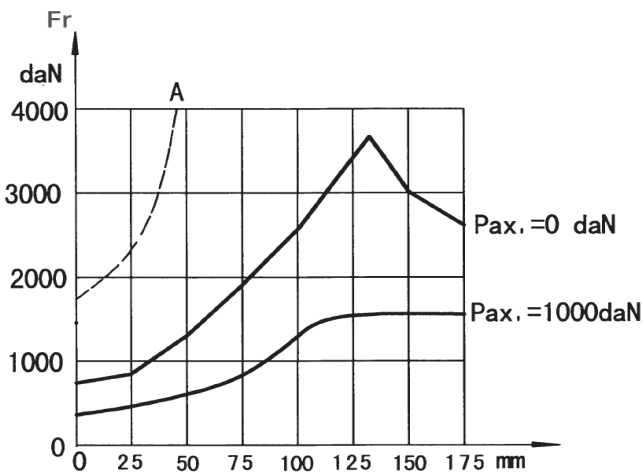

The output shaft runs in tapered bearings that permit high axial and radial forces, Curve "A" shows max radial shaft load, Any shaft loads exceeding the values quoted in the curve will involve a risk of breakage, The two other curves apply to a B10 bearing life of 3000 hours at 200 RPM.

GT Series Hydraulic Motors

Options

- Flange and wheel mount
- Bearingless motor
- Motor with brake
- Tachometer connection
- Speed sensing
- Side and rear ports
- Straight, splined and tapered shafts
- Metric and BSPP ports
- Other special features

Applications

- Metal working machines
- Agricultural machines
- Road building machines
- Mining machines
- Food industries
- Special vehicles
- Injection molding machines
- Conveyors



General

Max. Displacement	cm ³ /rev [in ³ /rev]	724,3 [44.2]
Max. Speed	RPM	775
Max. Torque	daNm [lb-in]	cont.: 130 [11500] int.: 148 [13100]
Max. Output	kW [HP]	40 [54]
Max. Pressure Drop	bar [PSI]	cont.: 200 [2900] int.: 240 [3480]
Max. Oil Flow	lpm [GPM]	150 [39.6]
Min. Speed	RPM	5
Pemissible Shaft Loads	daNm[lbs]	Pa=1000 [2250]
Operating Fluid		Mineral based- HLP (DIN 51524) or HM (ISO 6743/4)
Temperature Range	°C [°F]	-40–140[-104 –284]
Optimal Viscosity range	mm ² /s [SUS]	20–75[98–347]
Filtration	GT	ISO code 20/16 (Min. recommended fluid filtration of 25 microns)

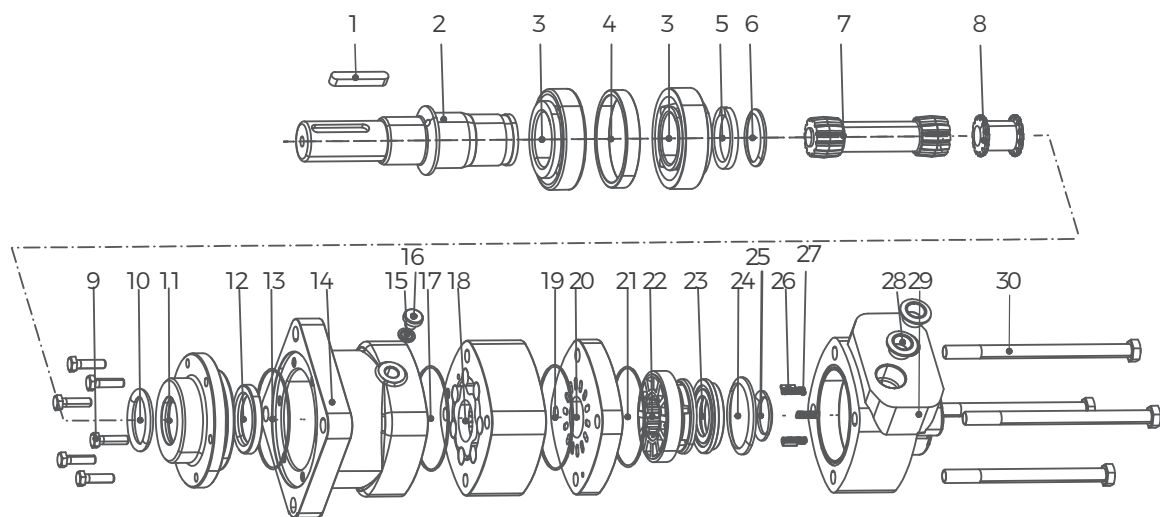

- | | | | | |
|--------------------------|----------------------|---------------------|----------------------------|-----------------------|
| 1 Parallel key | 7 Transmission shaft | 13 O-ring | 19 O-ring | 25 Small special ring |
| 2 Output shaft | 8 Coupling shaft | 14 Housing | 20 Balance plate | 26 Positioning pins |
| 3 Tapered roller bearing | 9 Hexagon screws | 15 Washer | 21 O-ring | 27 Spring |
| 4 Bearing outer retainer | 10 O-ring | 16 Plug | 22 Flow distribution plate | 28 Oil port plug cap |
| 5 Washers | 11 Front cover | 17 O-ring | 23 Flow pressure plate | 29 Rear housing |
| 6 Special shape ring | 12 Shaft seal | 18 Rotor and stator | 24 Large special ring | 30 Screw |



Ordering Code

GT SERIES		DISP	FLANGE	SHAFT	PORTS	ROTATION	PAINT	FUNCTION
CODE	TYPE	CODE	CODE	CODE	CODE	CODE	CODE	CODE
GT	Orbital motor		H6	4- Ø14 square Ø160, pilot Ø125×9				
GTS	Bearingless motor	DISP cm³/rev [in³/rev]	H7	4- Ø14.5 square Ø162, pilot Ø127×9	SK	Ø40 parallel key 12×8×70	A	Standard
		160	1611 [9.83]	H8	SL	Ø38.1 parallel key 9.53×9.53×57.15	R	Opposite
		200	201.4 [12.29]	W2	R9	Ø38.1 splined tooth 17-DP 12/24		
		250	251.8 [15.36]	B2	RA	Ø38.1 splined tooth 17-DP 12/24	CODE	PAINT
		315	326.3 [19.90]	H8	T6	Tapered 1:10 Ø45 parallel key B12×8×28	A	No Paint
		400	410.9 [25.06]	H8	T7	Tapered 1:8 Ø45 parallel key 11.13×11.13×31.75	B	Blue
		500	523.6 [31.95]	H8	R7	Ø34.85 splined tooth 6-34.85×28.14×8.64	C	Black
		630	631.2 [38.52]	H8	SM	Ø31.75 parallel key 7.96×7.96×40	S	Silver grey
		725	724.3 [44.2]	H8	R3	Ø31.75 splined tooth 14-DP 12/24		
							CODE	FUNCTION
							A	Standard
							N	Big radial force
							D	No case drain
							F	Free running
							L	Low speed
							V	High Temp
							S	Low Temp
					CODE	PORTS		
					G3	G3/4, G1/4 manifold 4×M10		
					M5	M27×2, M14×1.5 manifold 4×M10		
					U4	1-1/16-12UN O-ring, 9/16-18UNF		
					U5	1-1/16-12UN O-ring, 7/16-20UNF		
					G4	G3/4, G1/4		
					M9	M27×2, M14×1.5		



Specifications

Type		GT160	GT200	GT250	GT315	
Displacement, cm ³ /rev [in ³ /rev]		161,1[9.83]	201,4[12.29]	251,8[15.36]	326,3[19.90]	
Max. Speed, RPM	Cont.	622	620	496	382	
	Int.*	775	752	601	461	
Max. Torque daNm [lb-in]	Cont.	47[4160]	59[5220]	73[6460]	95[8410]	
	Int.*	56[4960]	71[6285]	88[7790]	114[10090]	
	Peak**	66[5840]	82[7260]	102[9030]	133[11770]	
Max. Output kW [HP]	Cont.	26,5[36]	33,5[45]	33,5[45]	33,5[45]	
	Int.*	32[43]	40[54]	40[54]	40[54]	
Max. Pressure Drop bar [PSI]	Cont.	200[2900]	200[2900]	200[2900]	200[2900]	
	Int.*	240[3480]	240[3480]	240[3480]	240[3480]	
	Peak**	280[4050]	280[4050]	280[4050]	280[4050]	
Max. Oil Flow lpm [GPM]	Cont.	100[26]	125[33]	125[33]	125[33]	
	Int.*	125[33]	150[39.6]	150[39.6]	150[39.6]	
Max. Inlet Pressure bar [PSI]	Cont.	210[3050]	210[3050]	210[3050]	210[3050]	
	Int.*	250[3600]	250[3600]	250[3600]	250[3600]	
	Peak**	300[4350]	300[4350]	300[4350]	300[4350]	
Max. Return Pressure without Drain Line bar [PSI]	Cont.	140[2030]	140[2030]	140[2030]	140[2000]	
	Int.*	175[2540]	175[2540]	175[2540]	175[2500]	
	Peak**	210[3050]	210[3050]	210[3050]	210[3000]	
Max. Starting Pressure with Unloaded Shaft, bar [PSI]		10[150]	10[150]	10[150]	10[150]	
Min. Starting Torque daNm [lb-in]	At max. press. drop Cont.	34[3010]	43[3800]	53[4690]	74[6550]	
	At max. press. drop Int.*	41[3630]	52[4600]	63[5580]	89[7880]	
Min. Speed, RPM		10	9	8	7	
Weight, kg [lb]		GT	20[44.1]	21,5[47.4]	21[46.3]	22[48.5]
For Reare Ports +0,450 [.992]		GTS	15[33.1]	15,5[34.2]	16[35.3]	17[37.5]



Specifications

Type		GT400	GT500	GT630	GT725
Displacement, cm ³ /rev [in ³ /rev]		410,9[25.06]	523,6[31.95]	631,2[38.52]	724,3[44.2]
Max. Speed	Cont.	304	238	197	172
RPM	Int.*	368	289	234	209
Max. Torque	Cont.	108[9560]	122[10800]	130[11500]	127[11240]
daNm [lb-in]	Int.*	126[11150]	137[12125]	148[13100]	147[13010]
	Peak**	144[12745]	160[14160]	176[15580]	175[15490]
Max. Output	Cont.	30[40]	26,5[36]	24,3[33]	20,2[27]
kW [HP]	Int.*	35[47]	30[40]	27,5[37]	26,8[36]
Max. Pressure Drop	Cont.	180[2610]	160[2320]	140[2010]	120[1740]
bar [PSI]	Int.*	210[3050]	180[2610]	160[2320]	140[2010]
	Peak**	240[3480]	210[3050]	190[2760]	165[2395]
Max. Oil Flow	Cont.	125[33]	125[33]	125[33]	125[33]
lpm [GPM]	Int.*	150[39.6]	150[39.6]	150[39.6]	150[39.6]
Max. Inlet Pressure	Cont.	210[3050]	210[3050]	210[3050]	210[3050]
bar [PSI]	Int.*	250[3600]	250[3600]	250[3600]	250[3600]
	Peak**	300[4350]	300[4350]	300[2000]	300[4350]
Max. Return Pressure	Cont.	140[2000]	140[2000]	140[2500]	140[2000]
without Drain Line	Int.*	175[2500]	175[2500]	175[3000]	175[2500]
bar [PSI]	Peak**	210[3000]	210[3000]	210[3000]	210[3000]
Max. Starting Pressure with Unloaded Shaft, bar [PSI]		10[150]	10[150]	10[150]	10[150]
Min. Starting Torque	At max. press. drop Cont.	84[7435]	95[8410]	95[8410]	95[8410]
daNm [lb-in]	At max. press. drop Int.*	97[8585]	106[9380]	110[9740]	115[10180]
Min. Speed***, RPM		6	5	5	5
Weight, kg [lb]	GT	23[50.7]	24[52.9]	23,5[51.8]	24,5[54.0]
For Reare Ports +0,450 [.992]	CTS	18[39.7]	19[41.9]	18,5[40.8]	19,5[43.0]



Function Diagrams

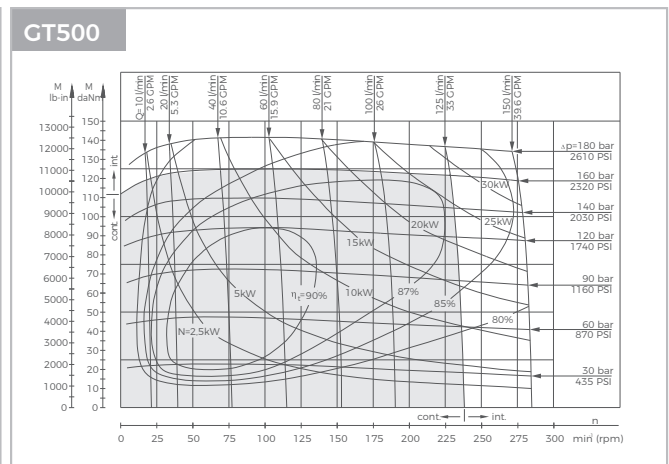
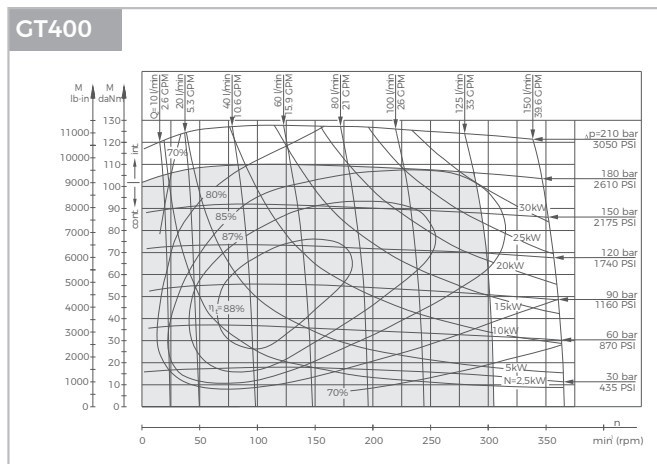
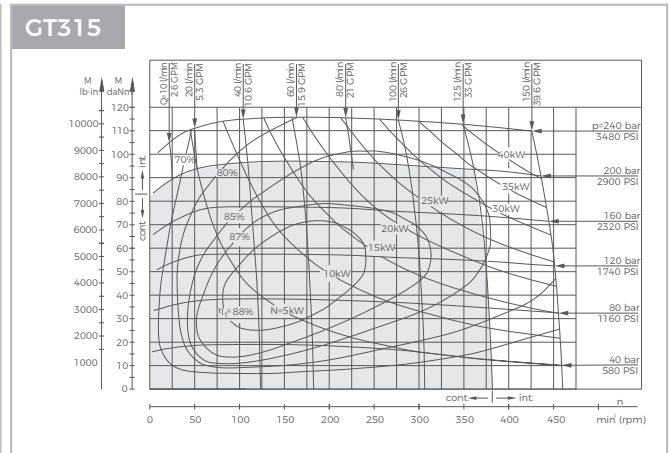
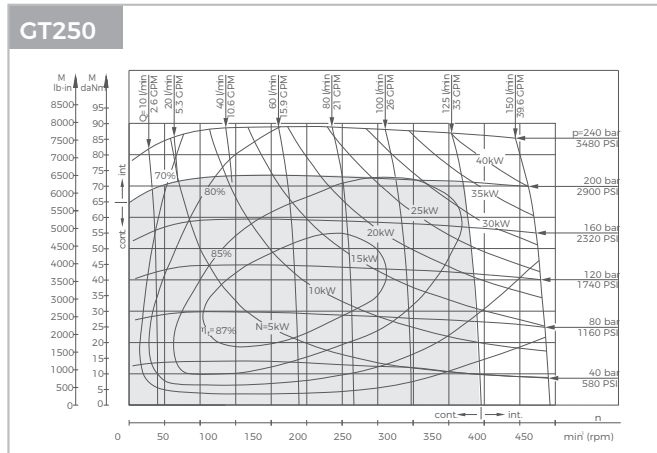
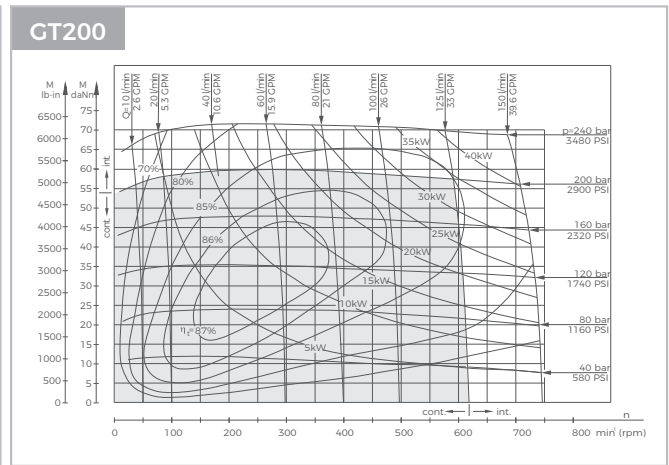
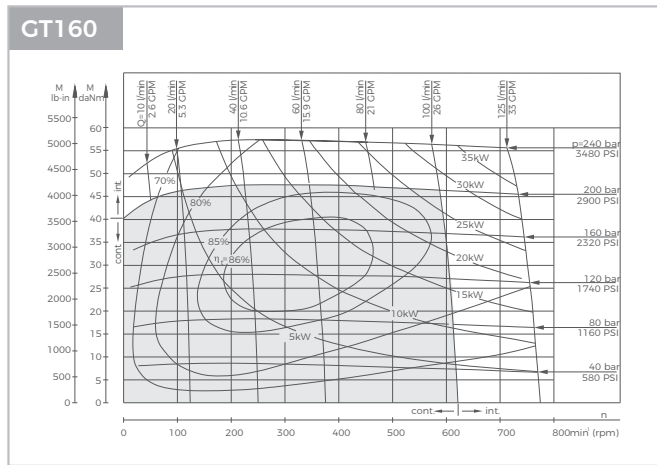

The function diagrams data is for average performance of randomly selected motors at backpressure. 5–10 bar [72.5–145 PSI] and oil with viscosity of 32 mm²/s [150 SUS] at 50°C [122°F].

Function Diagrams

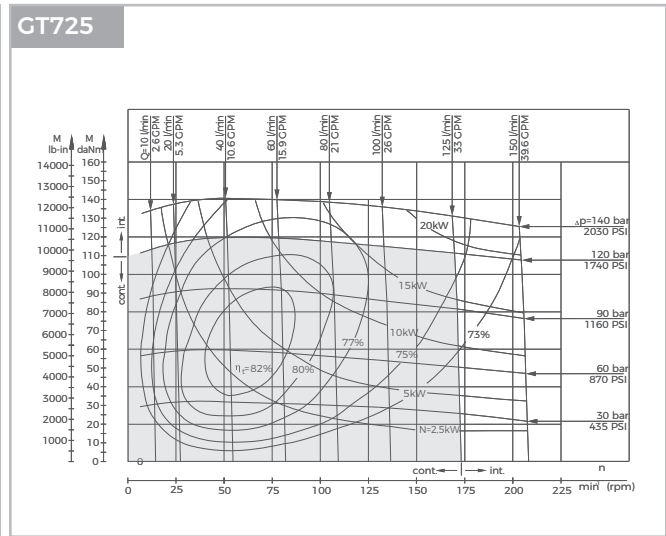
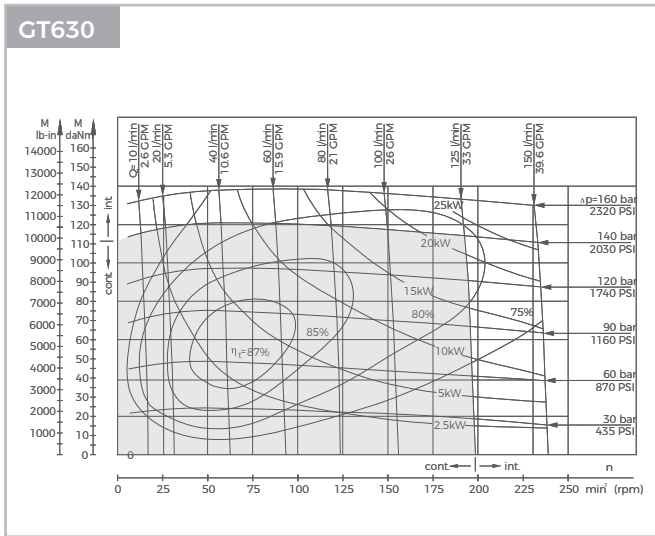

The function diagrams data is for average performance of randomly selected motors at backpressure. 5–10 bar [72.5–145 PSI] and oil with viscosity of 32 mm²/s [150 SUS] at 50°C [122°F].

GT Dimensions and Mountings

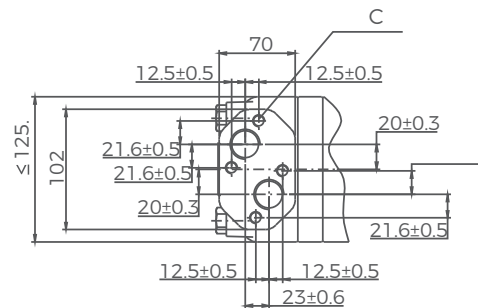
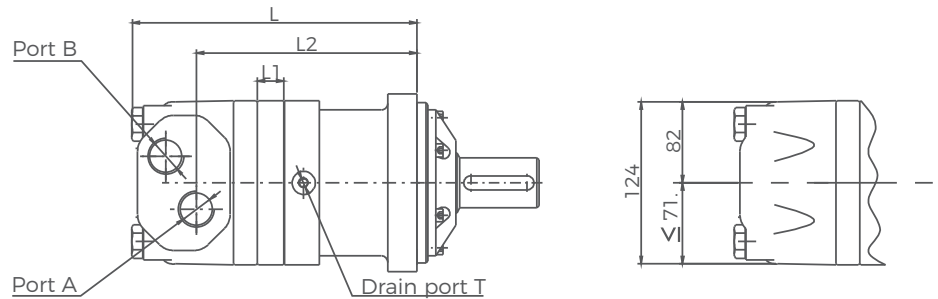

Model	L(mm)	L1(mm)	L2(mm)
GT160	193	17	142.5
GT200	197	21	146.5
GT250	204	14	152.5
GT315	210	20	158.5
GT400	217	27	165.5
GT500	225	35	173.5
GT630	237	47	185.5
GT725	248	58	196.5

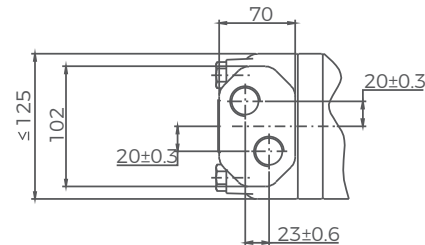

Mounting	G3 (depth)	M5 (depth)	U4 (depth)	M9 (depth)	U5 (depth)	G4 (depth)
P(A, B)	G3/4(18)	M27 x 2(18)	1-1/16-12 UN(18)	M27 x 2(18)	1-1/16-12 UN(18)	G3/4(18)
T	G1/4(12)	M14 x 1.5(12)	9/16-18 UNF(12)	M14 x 1.5(12)	7/16-20 UNF(12)	G1/4(12)
C	4-M10(10)	4-M10(10)	—	—	—	—

GT with Speed Sensor Dimensions and Mountings

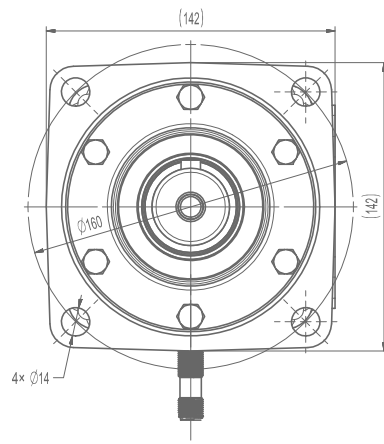
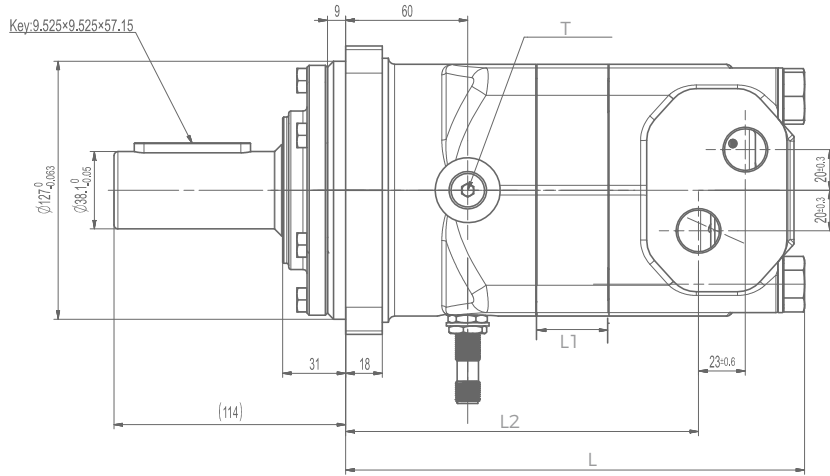

Pulse per revolution (PPR)	GT
	84

Model	L(mm)	L1(mm)	L2(mm)
GT160	193	17	142.5
GT200	197	21	146.5
GT250	204	14	152.5
GT315	210	20	158.5
GT400	217	27	165.5
GT500	225	35	173.5
GT630	237	47	185.5
GT725	248	58	196.5

Mounting	G3 (depth)	M5 (depth)	U4 (depth)	M9 (depth)	U5 (depth)
P(A, B)	G3/4(18)	M27 x 2(18)	1-1/16-12 UN(18)	M27 x 2(18)	1-1/16-12 UN(18)
T	G1/4(12)	M14 x 1.5(12)	9/16-18 UNF(12)	M14 x 1.5(12)	7/16-20 UNF(12)
C	4-M10(10)	4-M10(10)	—	—	—

GTS Bearingless Motor Dimensions and Mounting

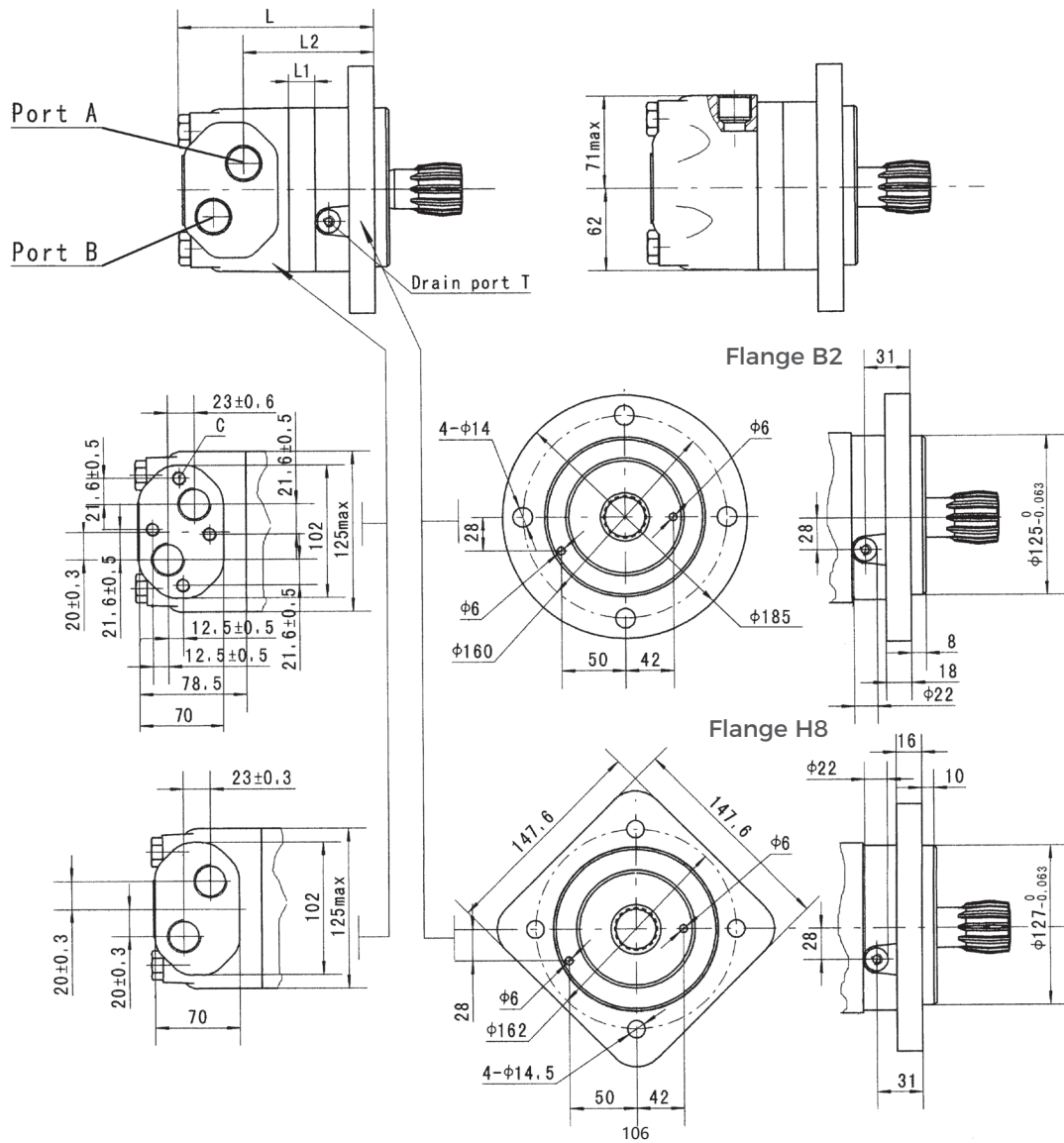

Model	L(mm)	L1(mm)	L2(mm)
GTS160	148	17	96.5
GTS200	152	21	100.5
GTS250	157	14	109
GTS315	163	20	115
GTS400	170	27	122
GTS500	178	35	130
GTS630	190	47	142
GTS725	201	58	153

Mounting	G3	M5	U4	M9	U5
	(depth)	(depth)	(depth)	(depth)	(depth)
P(A, B)	G3/4(18)	M27 x 2(18)	1-1/16-12 UN(18)	M27 x 2(18)	1-1/16-12 UN(18)
T	G1/4(12)	M14 x 1.5(12)	9/16-18 UNF(12)	M14 x 1.5(12)	7/16-20 UNF(12)
C	4-M10(10)	4-M10(10)	—	—	—

GT Flange Covers Dimensions

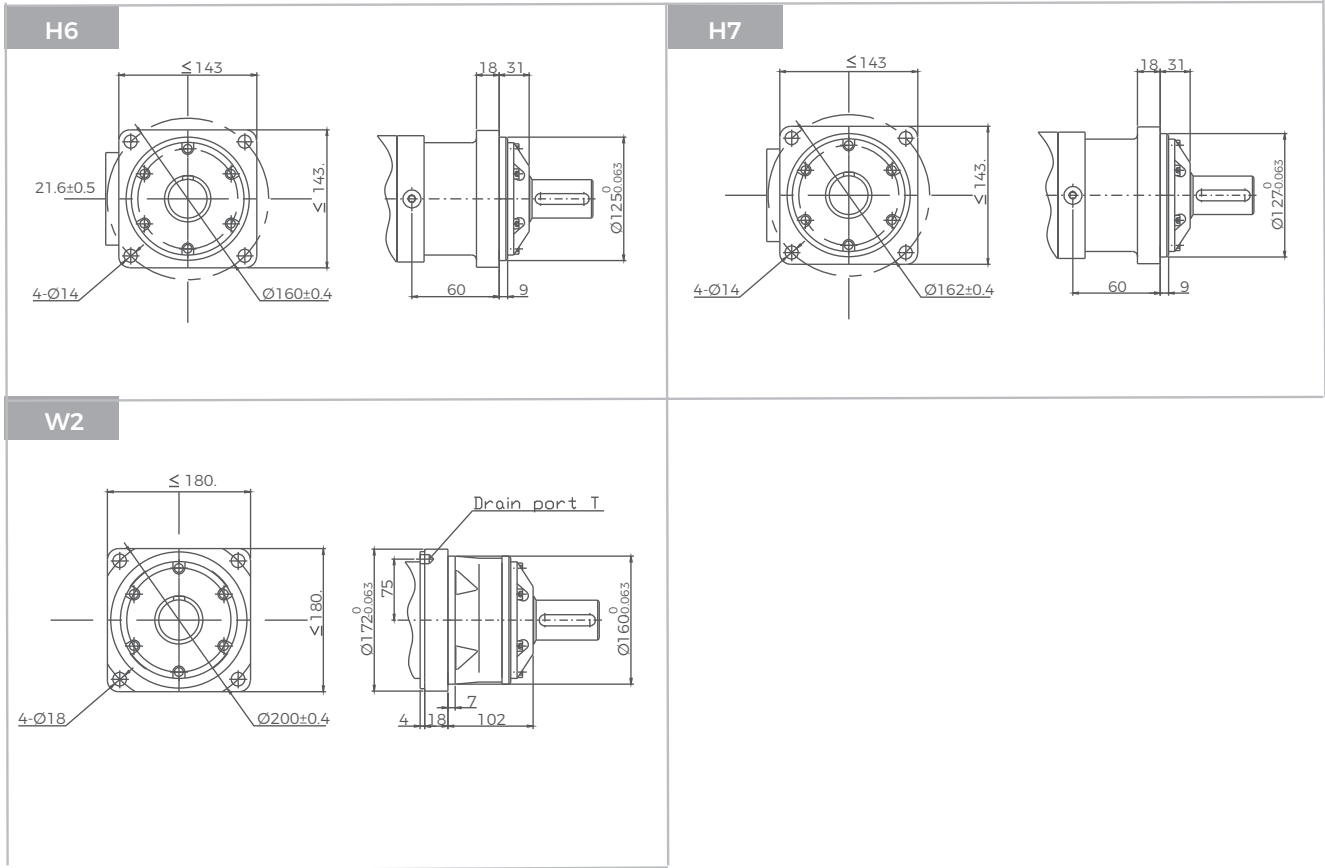

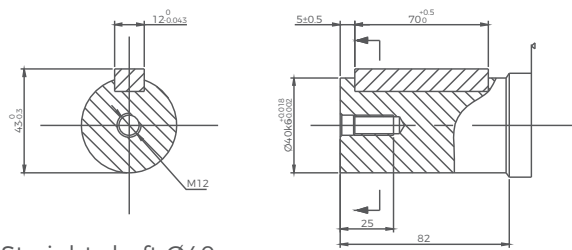
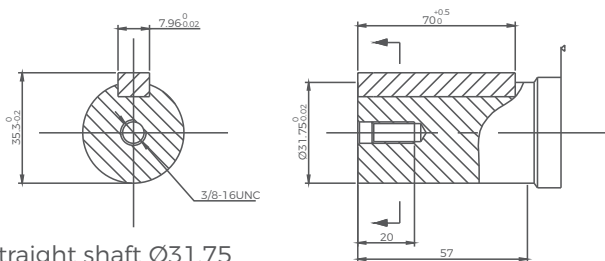
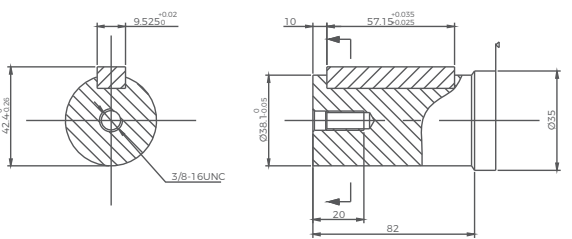
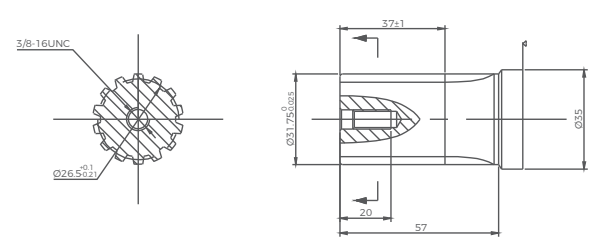
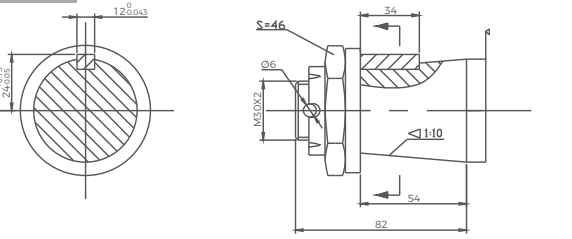
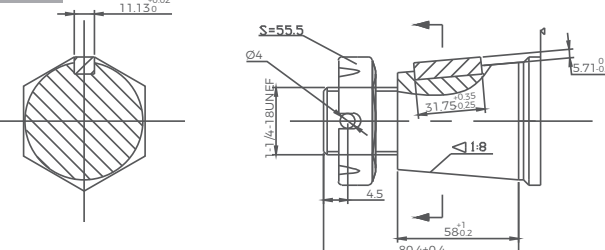

GT Shafts Dimensions

<p>SK</p>  <p>Straight shaft Ø40 Parallel key 12 x 8 x 70</p>	<p>SM</p>  <p>Straight shaft Ø31.75 Parallel key 7.96 x 7.96 x 40</p>
<p>SL</p>  <p>Straight shaft Ø38.1 Parallel key 9.525 x 9.525 x 57.15</p>	<p>R3</p>  <p>Splined shaft 14-DP 12/24</p>
<p>T6</p>  <p>Tapered shaft Ø45 Parallel key B12 x 8 x 28 Tightening torque: 500 ± 10 Nm</p>	<p>T7</p>  <p>Tapered shaft Ø45 Parallel key 11.13 x 11.13 x 31.75 Tightening torque: 500 ± 10 Nm</p>

GT Shafts Dimensions

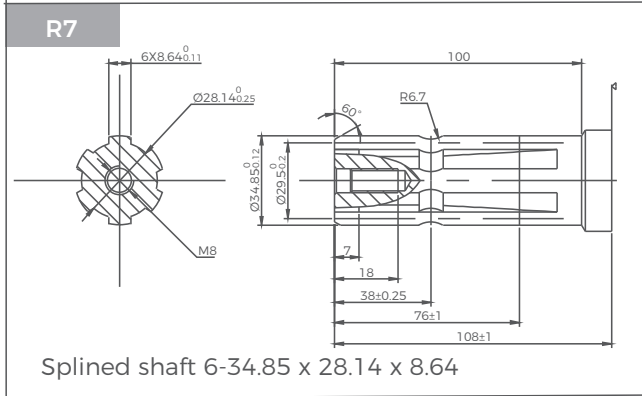
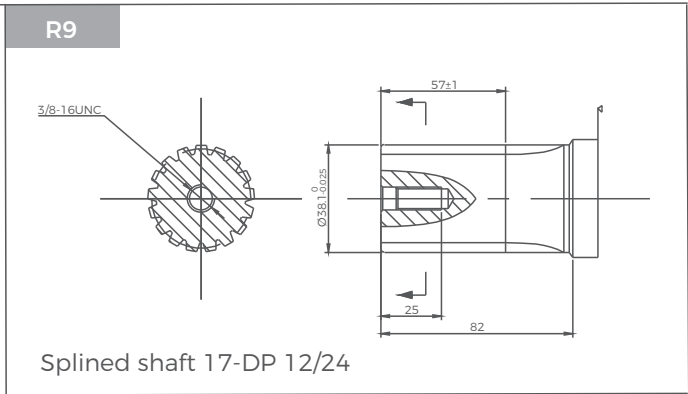
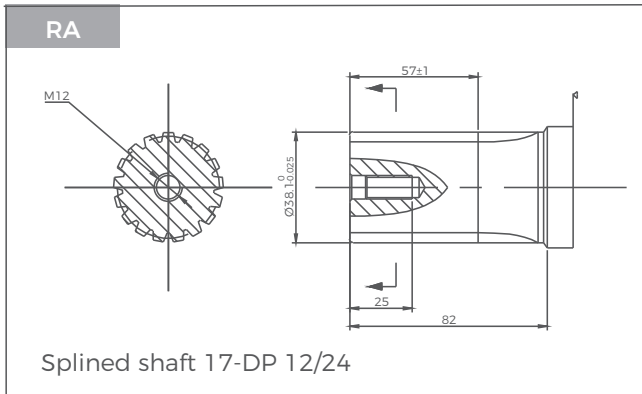

GT Series Hydraulic Motors

Permissible shaft seal pressure

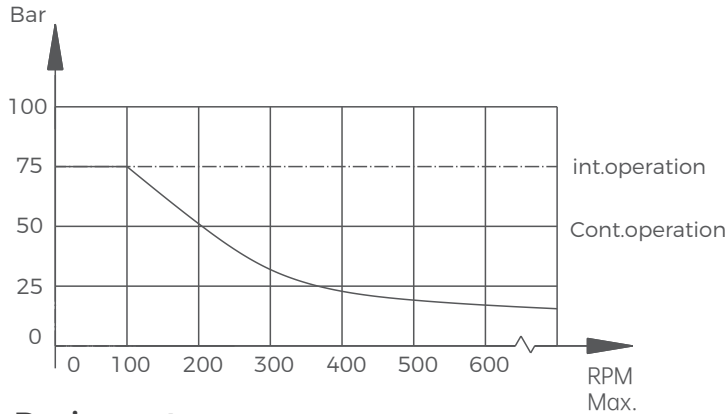

Drain port

In applications without drain line, output shaft seal exceeds a bit of the pressure in the return line. In applications using the drain line, the pressure of output shaft seal equals the pressure in drain line.

Standard direction of shaft rotation: Standard

When facing shaft end of motor, shaft to rotate:
Clockwise. When port A is pressurized.
Counter-clockwise port B is pressurized.

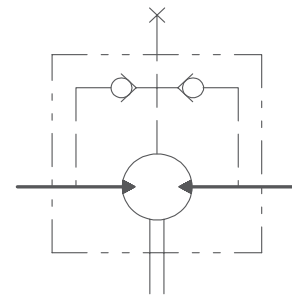

GT with standard shaft seal check valves and without use of drain connection: The pressure on the shaft seal never exceeds the pressure in the return line.

GT with standard shaft seal, check valves and with drain connection: The shaft seal pressure equals the pressure on the drain line.

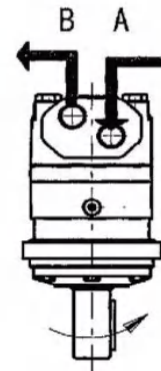

Axial and radial force

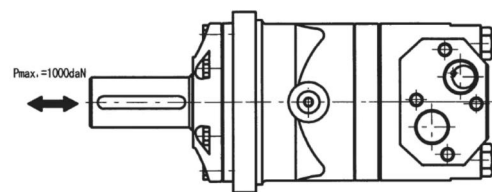
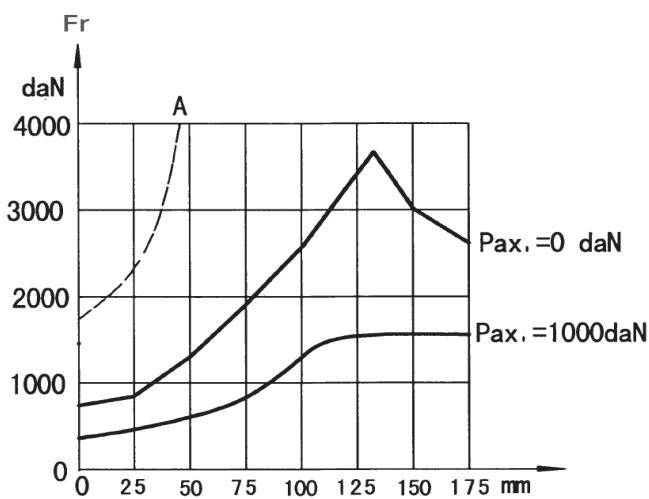

The output shaft runs in tapered bearings that permit high axial and radial forces, Curve "A" shows max radial shaft load, Any shaft loads exceeding the values quoted in the curve will involve a risk of breakage, The two other curves apply to a B10 bearing life of 3000 hours at 200 RPM.

GV Series Hydraulic Motors

Options

- Flange connection
- Bearingless motor
- Tachometer connection
- Side ports
- Straight, splined and tapered shafts
- Metric and BSPP ports
- Other special features

Applications

- Conveyors
- Metal working machines
- Agricultural machines
- Road building machines
- Mining machines
- Food industries
- Special vehicles
- Injection molding machines





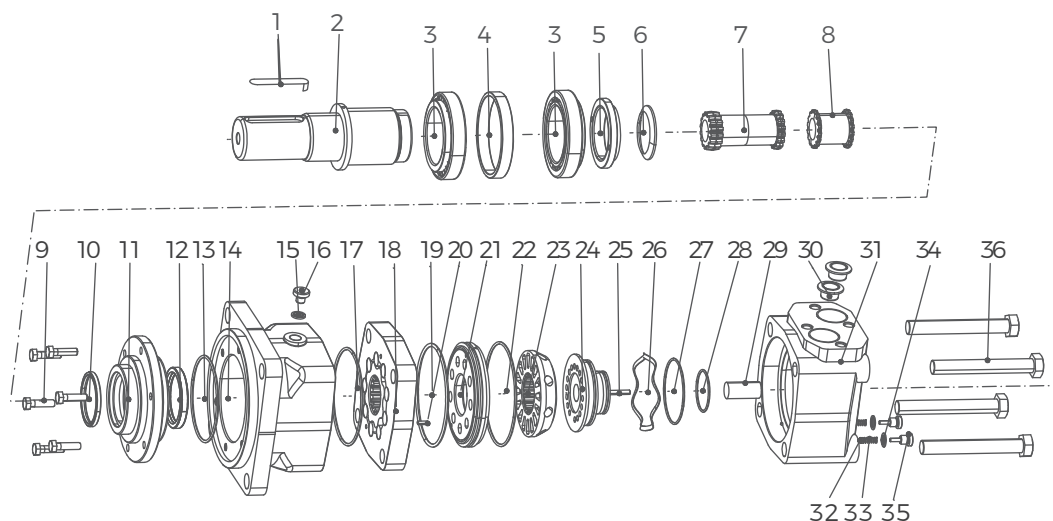

General

Max. Displacement	cm ³ /rev [in ³ /rev]	801,8 [48.91]
Max. Speed	RPM	630
Max. Torque	daNm [lb-in]	cont.: 188 [16650] int.: 211 [18650]
Max. Output	kW [HP]	64 [85,8]
Max. Pressure Drop	bar [PSI]	cont.: 200 [2900] int.: 240 [3480]
Max. Oil Flow	lpm [GPM]	240 [63.4]
Min. Speed	RPM	5
Permissible Shaft Loads	daNm [lbs]	Pa=1500 [3300]
Pressure fluid		Mineral based- HLP (DIN 51524) or HM (ISO 6743/4)
Temperature Range	°C [°F]	-40–140[-104–284]
Optimal Viscosity range	mm ² /s [SUS]	20–75[98–347]
Filtration		ISO code 20/16 (Min. recommended fluid filtration of 25 microns)

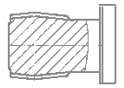

- | | | | | |
|----------------------|-------------------|---------------------|-------------------------------|----------------------|
| 1 Parallel Key | 8 Coupling shaft | 15 Washer | 22 O-ring | 29 Limit posts |
| 2 Output shaft | 9 Hexagon screws | 16 Plugs | 23 Flow distribution plate | 30 Oil port plug cap |
| 3 Roller bearing | 10 Anti-dust ring | 17 O-ring | 24 Distributor pressure plate | 31 Rear cover |
| 4 Bearing retainer | 11 Front cover | 18 Rotor and stator | 25 Positioning pins | 32 Steel ball |
| 5 Lock nut | 12 Shaft seal | 19 O-Ring | 26 Wave spring | 33 Spring |
| 6 Special shape ring | 13 O-ring | 20 Positioning pins | 27 O-ring | 34 Washer |
| 7 Transmission shaft | 14 Housing | 21 Balance plate | 28 O-ring | 35 Hexagon plugs |
| | | | | 36 Screw |

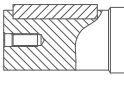
Ordering Code

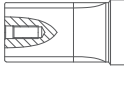
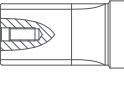
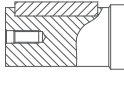
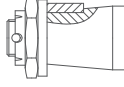
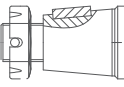
GV SERIES		DISP		FLANGE		SHAFT		PORTS		ROTATION		PAINT		FUNCTION	
CODE	TYPE	CODE	DISP cm ³ /rev [in ³ /rev]	CODE	FLANGE	CODE	SHAFT	CODE	PORTS	CODE	ROTATION	CODE	PAINT	CODE	FUNCTION
GV	Orbital motor	315	314.5 [19.18]	H9	4- Ø18 square Ø200, pilot Ø160×11 	C3	Cardan 16-DP 10/20 	G5	G1, G1/4 manifold 4×M12	A	Standard	A	No paint	A	Standard
CVS	Bearingless motor	400	400.9 [24.45]	W3	4- Ø18 wheel Ø224, pilot Ø180×10 	SN	Ø50 parallel key 14×9×70 	M6	M33×2, M14×1.5 manifold 4×M12	R	Opposite	B	Blue	V	High temp
		500	499.6 [30.48]	H7	4- Ø14 square Ø180, pilot Ø140×8 	RB	Ø53.975 splined key 16-DP 8/16 	U6	1-5/16-12UNF O-ring manifold 9/16-18UNF	C	Black	C	Black	S	Low temp
		630	629.1 [38.38]			RC	Ø53.975 splined key 16-DP 8/16 	G6	G1, G1/4	S	Silver grey				
		800	801.8 [48.91]			SP	Ø57.15 parallel key 12.7×12.7×57.16 	M7	M33×2, M14×1.5						
						T8	Tapered Ø57.15 parallel key 16×10×32 	U7	1-5/16-12UNF O-ring 7/16-20UNF						
						T9	Tapered Ø60 parallel key 14.308×14.308×508 								

Specifications

Type		GV315	GV400	GV500	GV630	GV800
Displacement, cm ³ /rev [in ³ /rev]		314,5[19.18]	400,9[24.45]	499,6[30.48]	629,1[38.38]	801,8[48.91]
Max. Speed	Cont.	510	500	400	320	250
RPM	Int.*	630	600	480	380	300
Max. Torque	Cont.	92[8150]	118[10450]	146[12950]	166[14700]	188[16650]
daNm [lb-in]	Int.*	111[9800]	141[12500]	176[15550]	194[17150]	211[18650]
	Peak**	129[11400]	164[14500]	205[18150]	221[19550]	247[21850]
Max. Output	Cont.	42,5[57]	53,5[71.7]	53,5[71.7]	48[64.4]	42,5[57]
kW [HP]	Int.*	51[68.4]	64[85.8]	64[85.8]	56[75]	48[64.4]
Max. Pressure Drop	Cont.	200[2900]	200[2900]	200[2900]	180[2610]	160[2320]
bar [PSI]	Int.*	240[3480]	240[3480]	240[3480]	210[3050]	180[2610]
	Peak**	280[4060]	280[4060]	280[4060]	240 [3480]	210[3050]
Max. Oil Flow	Cont.	160[42.3]	200[52.8]	200[52.8]	200[52.8]	200[52.8]
lpm [GPM]	Int.*	200[52.8]	240[63.4]	240[63.4]	240[63.4]	240[63.4]
Max. Inlet Pressure	Cont.	210[3050]	210[3050]	210[3050]	210[3050]	210[3050]
bar [PSI]	Int.*	250[3620]	250[3620]	250[3620]	250[3620]	250[3620]
	Peak**	300[4350]	300[4350]	300[4350]	300[4350]	300[4350]
Max. Return Pressure	Cont.	140[2040]	140[2040]	140[2040]	140[2040]	140[2040]
without Drain Line	Int.*	175[2540]	175[2540]	175[2540]	175[2540]	175[2540]
bar [PSI]	Peak**	210[3050]	210[3050]	210[3050]	210[3050]	210[3050]
Max. Starting Pressure with Unloaded Shaft, bar [PSI]		8[120]	8[120]	8[120]	8[120]	8[120]
Min. Starting Torque daNm [lb-in]	At max. press. drop Cont.	71[6300]	91[8100]	113[10000]	133[11800]	151[13400]
	At max. press. drop Int.*	85[7500]	109[9600]	136[12000]	155[13700]	170[15000]
Min. Speed, RPM		10	9	8	6	5
Weight, kg [lb]	GV	31,8[70.1]	32,6[71.9]	33,5[73.8]	34,9[76.9]	36,5[80.5]
	GVS	22,7[50]	23,5[51.8]	24,4[53.8]	25,6[56.4]	27,7[61.1]



Function Diagrams

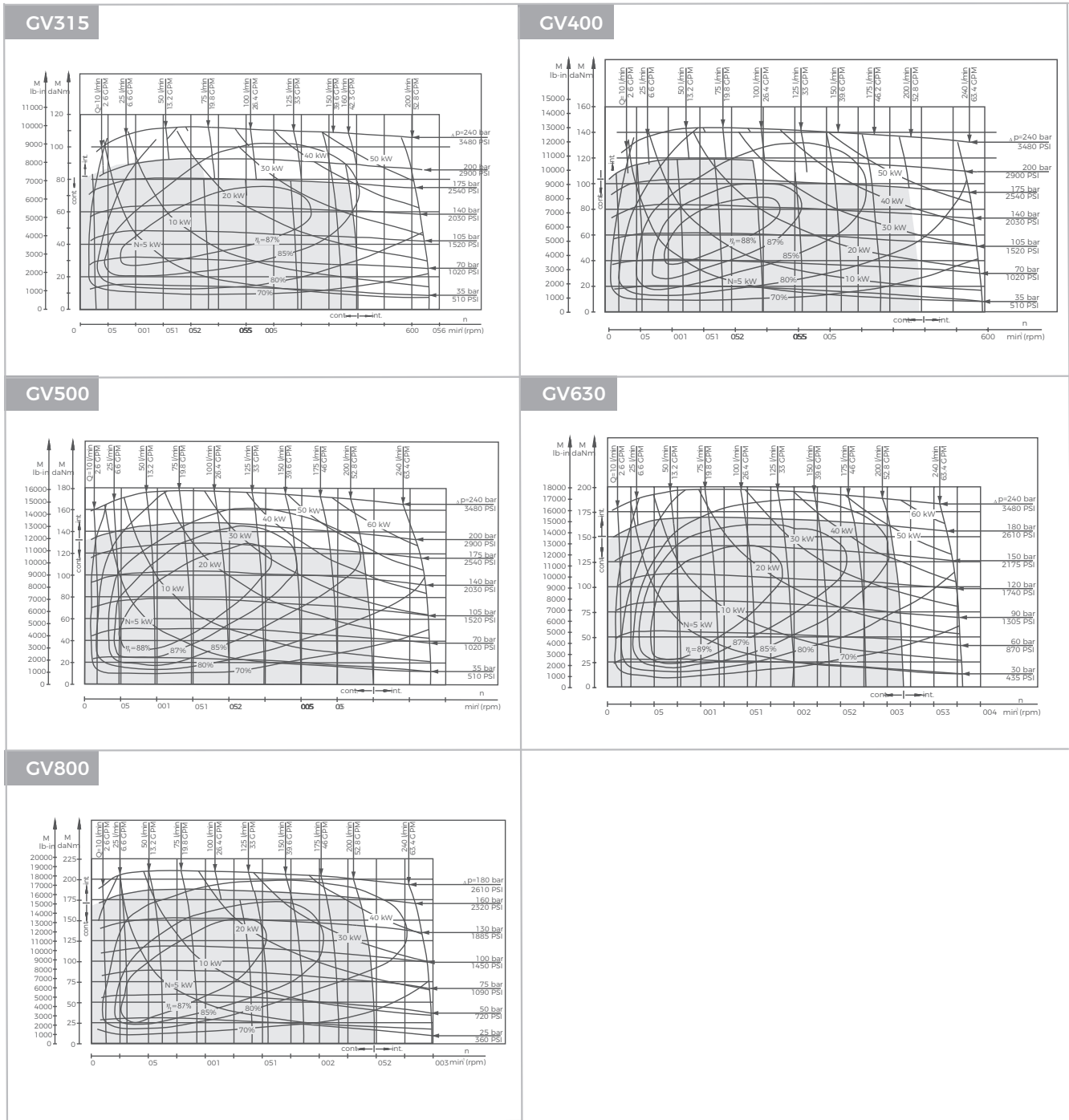

The function diagrams data is for average performance of randomly selected motors at backpressure. 5–10 bar [72.5–145 PSI] and oil with viscosity of 32 mm²/s [150 SUS] at 50°C [122°F].

GV Dimensions and Mountings

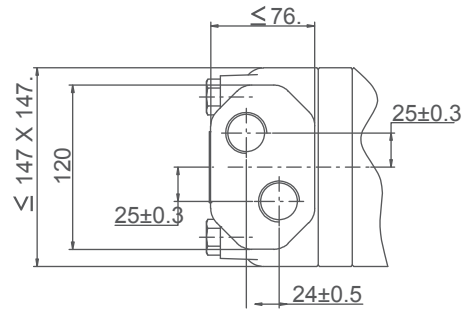
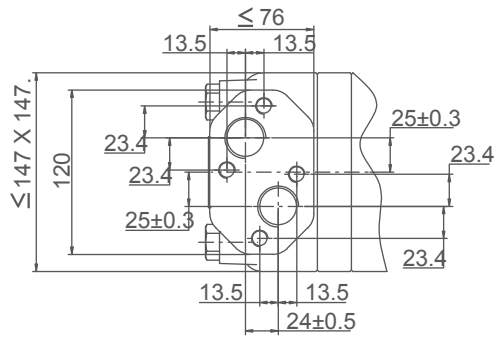
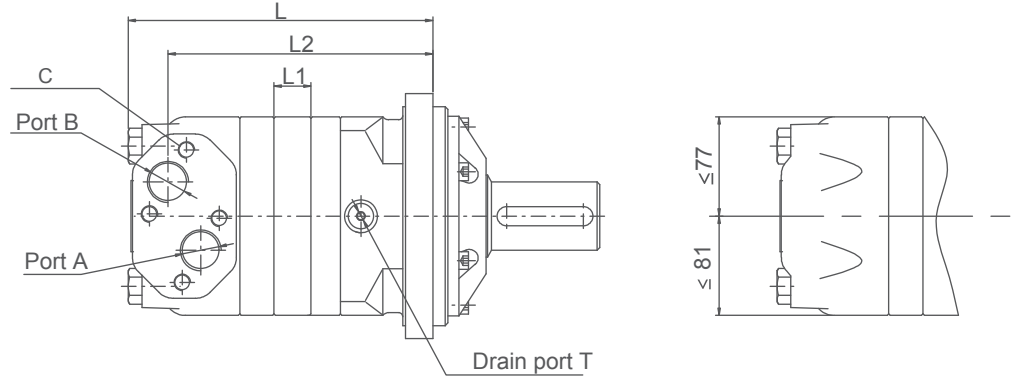

Model	L(mm)	L1(mm)	L2(mm)
GVS315	171	22	117
GVS400	179	29	124
GVS500	186	37	132
GVS630	197	47.5	143
GVS800	211	61.5	157

Mounting	G5 (depth)	M6 (depth)	U6 (depth)	G6 (depth)	M7 (depth)	U7 (depth)
P(A, B)	G1(18)	M33 X 12(18)	1-5/16-12UN(18)	G1(18)	M33 X 2(18)	1-5/16-12UN(18)
T	G1/4(12)	M14 X 1.5(12)	9/16-18UNF(12)	G1/4(12)	M14 X 1.5 (12)	7/16-20UNF(12)
C	4-M12(12)	4-M12(12)				

GVS Bearingless Motor Dimensions and Mountings

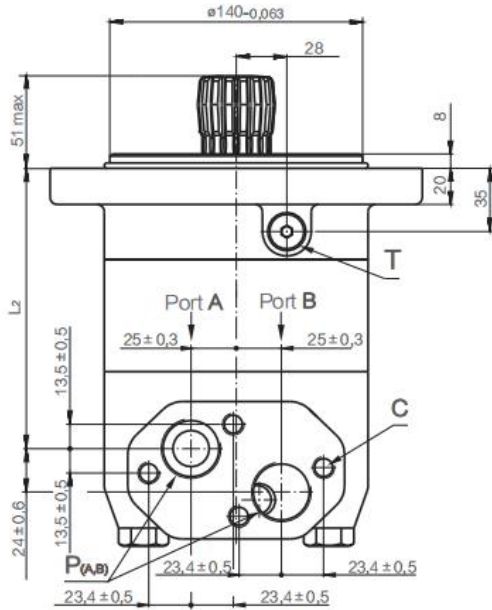

Flange S

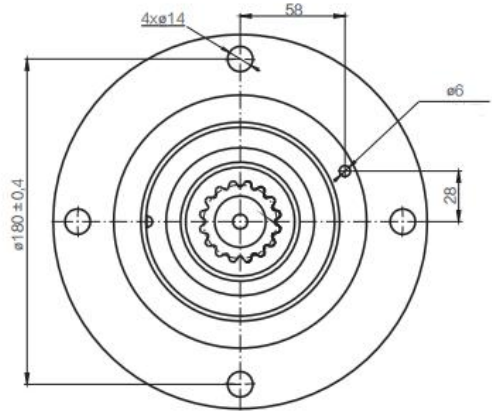
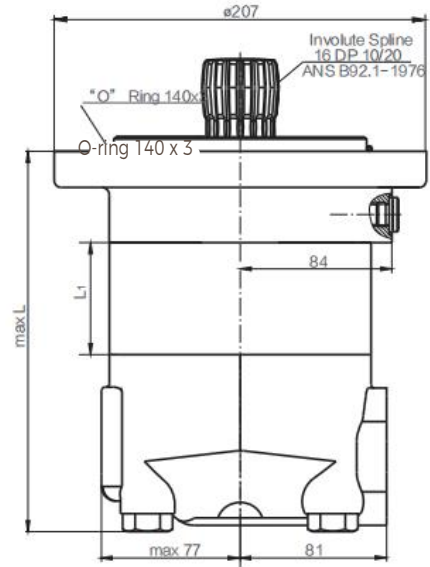

Model	L(mm)	L1(mm)	L2(mm)
GVS315	171	22	117
GVS400	179	29	124
GVS500	186	37	132
GVS630	197	47.5	143
GVS800	211	61.5	157

Mounting	G5 (depth)	M6 (depth)	U6 (depth)	G6 (depth)	M7 (depth)	U7 (depth)
P(A, B)	G1(18)	M33 X 12(18)	1-5/16-12UN(18)	G1(18)	M33 X 2(18)	1-5/16-12UN(18)
T	G1/4(12)	M14 X 1.5(12)	9/16-18UNF(12)	G1/4(12)	M14 X 1.5 (12)	7/16-20UNF(12)
C	4-M12(12)	4-M12(12)				

GV Falnge Covers Dimensions

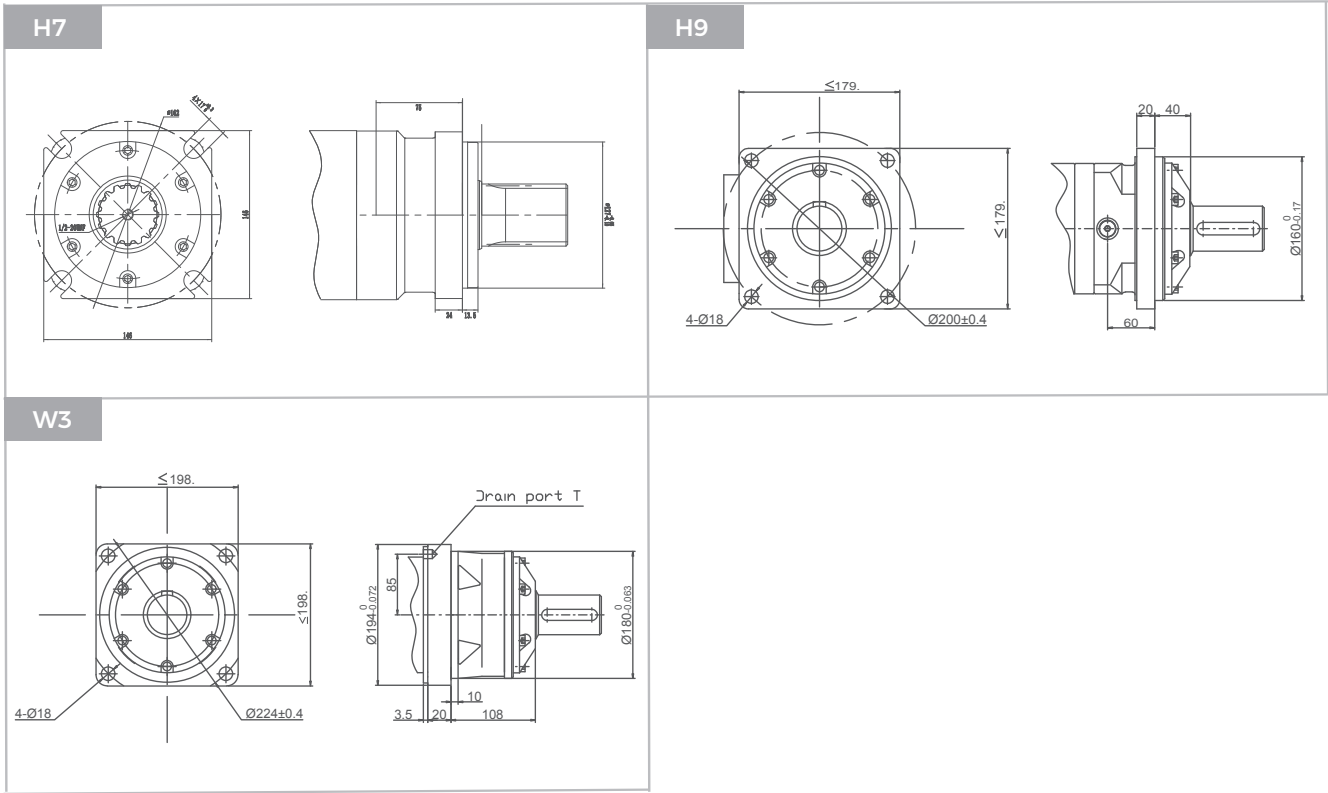



GV Shafts Dimensions

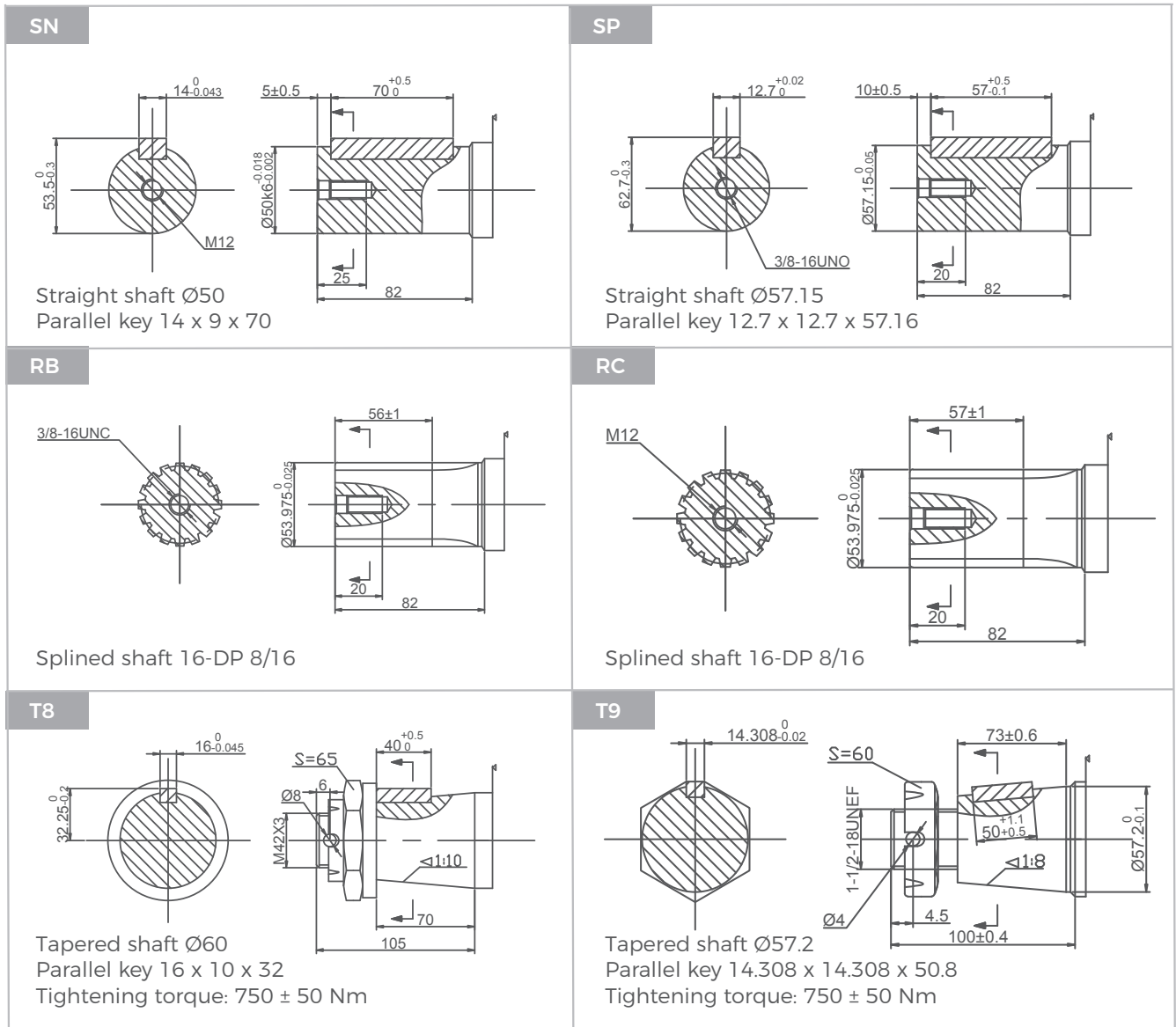

GV Series Hydraulic Motors

Permissible shaft seal pressure

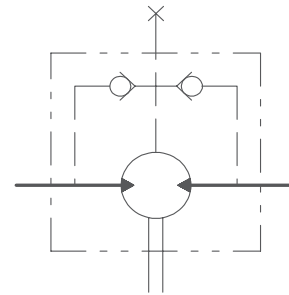
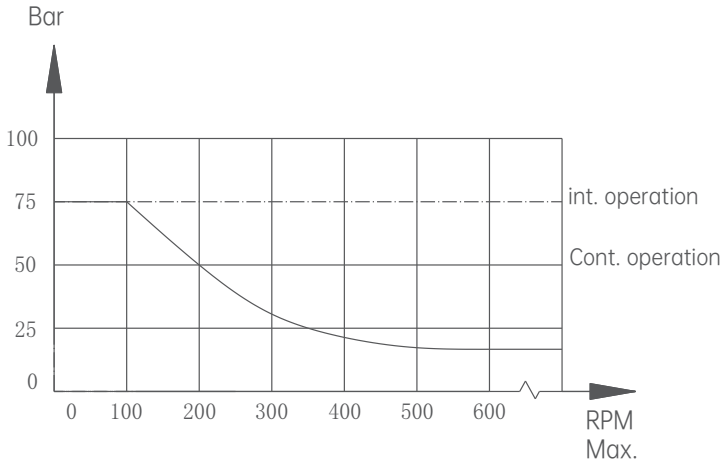

GV with standard shaft seal, check valves and without use of drain connection: The pressure on the shaft seal never exceeds the pressure in the return line.

GV with standard shaft seal, check valves and with drain connection: The shaft seal pressure equals the pressure on the drain line.

Drain Port

In applications without drain line, output shaft seal exceeds a bit of the pressure in the return line. In applications using the drain line, the pressure of output shaft seal equals the pressure in drain line.

Standard direction of shaft rotation: Standard

When facing shaft end of motor, shaft to rotate:
Clockwise when port "A" is pressurized.
Counter-clockwise when port "B" is pressurized.

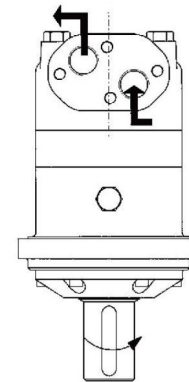

Output shaft axial and radial force

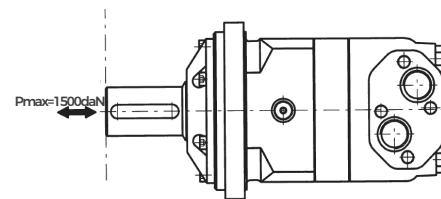
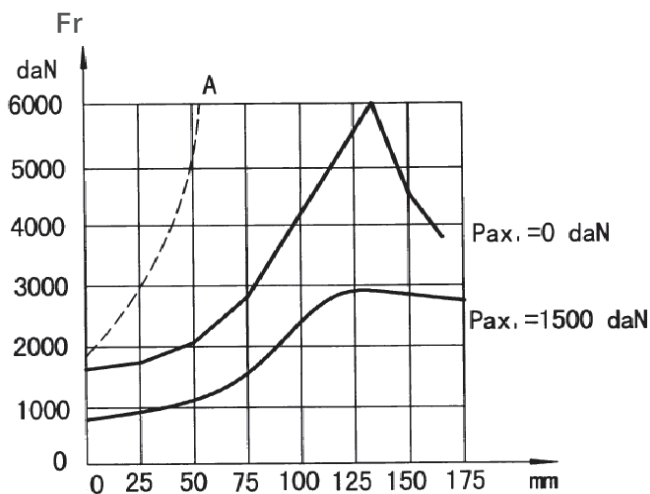

The output shaft runs in tapered bearings that permit high axial and radial forces, Curve "A" shows max radial shaft load, any shaft loads exceeding the values quoted in the curve will involve a risk of breakage, the tow other curves apply to a B10 bearing life of 3000 hours at 200 RPM.

CFA Series Hydraulic Motors

Options

- Flange connection
- Motor with needle roller bearing
- Speed sensing
- Side and rear ports
- Shaft seal for high and low pressure
- Straight, splined and tapered shafts
- Metric and BSPP ports
- Other special features

Applications

- Conveyors
- Feeding machiners
- Metal working machines
- Textile machines
- Agricultural machines
- Food industries
- Lawn mower







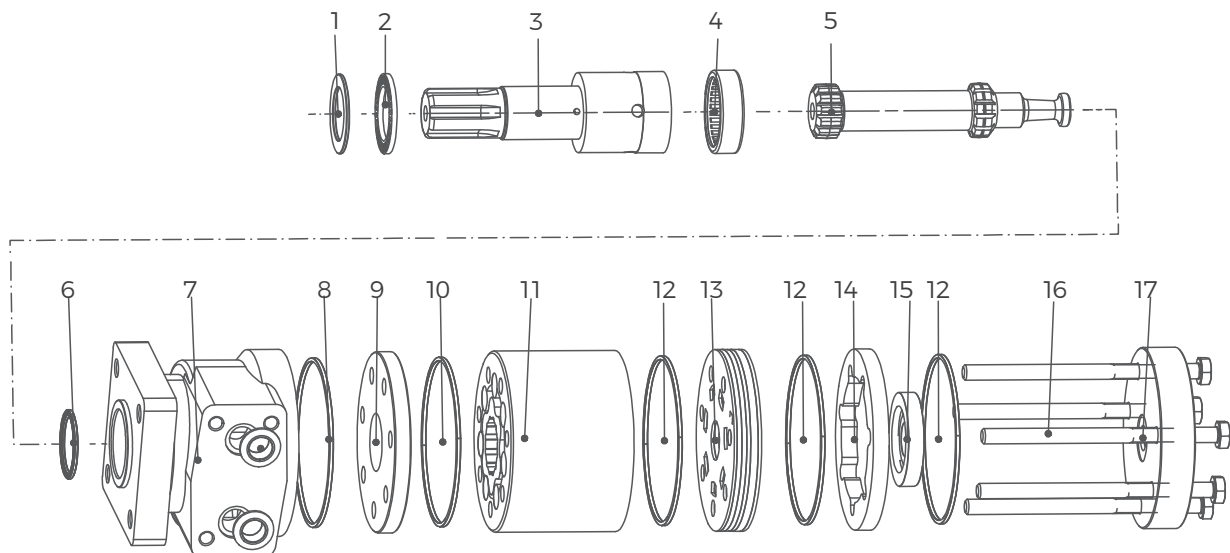





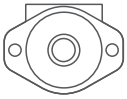



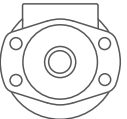

General

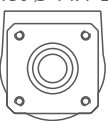
Max. Displacement	cm ³ /rev [in ³ /rev]	392 [24.0]
Max. Speed	RPM	1141
Max. Torque	daNm [lb-in]	cont.:44,5 [3935] int.:62,8 [5562]
Max. Output	kW [HP]	12.5 [16.8]
Max. Pressure Drop	bar [PSI]	cont.: 140 [2030] int.: 190 [2750]
Max. Oil Flow	lpm [GPM]	75 [20.0]
Pressure fluid		Mineral based- HLP (DIN 51524) or HM (ISO 6743/4)
Temperature Range	°C [°F]	-40–140[-104–284]
Optimal Viscosity range	mm ² /s [SUS]	20–75[98–347]
Filtration		ISO code 20/16 (Min. recommended fluid filtration of 25 microns)

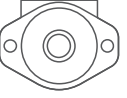

- | | | | |
|-------------------------------------|------------------|-----------------------|---------------|
| 1 Bearing retainer | 6 Anti-dust ring | 11 Rotor and stator | 16 Screw |
| 2 Flat bearing | 7 Housing | 12 O-ring | 17 Rear cover |
| 3 Output shaft | 8 O-ring | 13 Distribution plate | |
| 4 Cylindrical needle roller bearing | 9 Spacer | 14 Spacer | |
| 5 Transmission shaft | 10 O-ring | 15 Distribution ring | |

Ordering Code

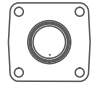
GFA SERIES		DISP	FLANGE	SHAFT	PORTS	ROTATION	PAINT	FUNCTION
CODE		DISP cm ³ /rev [in ³ /rev]	CODE	FLANGE	CODE	SHAFT	CODE	ROTATION
036		36 [2.0]	A1	2-Hole SAE A Ø106.4 pilot Ø82.5×2.55 	S6	Ø25.4 woodruff key Ø25.4×6.35 	A	Standard
045		41 [2.5]			R4	Ø25.4, splined key SAE 6B 1/4-20UNC 	R	Opposite
050		49 [3.0]			S7	Ø25 parallel key 8×7×32 		
065		65 [4.0]	A3	4-Hole SAE A Ø106.4 pilot Ø82.5×2.79 	S8	Ø25.4 parallel key 6.35×6.35×31.75 		
080		82 [5.0]			S9	Ø25.4, pin hole Ø10.3 		
100		98 [6.0]			SA	Ø25.4, pin hole Ø8 		
130		130 [7.9]	H4	4-3/8-16UNC square Ø82.5 pilot Ø44.4×2.8 	SB	Ø22.22 parallel key 6.35×6.35×25.4 		
165		163 [9.9]			R5	Ø22.22 splined key 13-DP 16/32 		
195		195 [11.9]	A5	4-M10 square Ø82.5 pilot Ø44.4×2.8 	T3	Tapered Ø25.4 1:8 woodruff key Ø25.4×6.35 		
230		228 [13.9]			SC	Ø25 parallel key 8×7×28 		
260		260 [15.9]	A7	2-Hole SAE B pilot Ø101.6×6.35 	SD	Ø25 parallel key 7×7×32 		
290		293 [17.9]			R1	Ø25.4 splined key SAE 6B 		
330		328 [20.0]						
365		370 [22.6]						
390		392 [23.9]	H6	4-Hole wheel pilot Ø60.32×31.75 				
					CODE	PORTS		
					G7	G1/2, G14		
					U9	7/8-14 UNF O-ring, 7/16-20UNF		
					UA	1/2-14 NPTF, 7/16-20UNF		
					U3	3/4-16 O-ring, 7/16-20UNF		
					G8	PT(Rc) 1/2, PT(Rc) 1/4		
					D1	Ø10 O-ring, 7/16-20UNF manifold 4×5/16-18UNC		
					D2	Ø10 O-ring, G1/4 manifold 4×M8		
							CODE	PAINT
							A	No paint
							B	Blue
							C	Black
							S	Silver grey
							CODE	FUNCTION
							A	Standard
							N	Big radial force
							D	No case drain
							F	Free running
							L	Low speed
							V	High temp.
							S	Low temp.

GFA Specifications

Type		GFA36	GFA45	GFA50	GFA65	GFA80
Displacement cm ³ /rev [in ³ /rev]		36[2.2]	41[2.5]	49[3.0]	65[4.0]	82[5.0]
Max. Speed RPM	Int.	1141	1024	1020	877	695
Max. Oil Flow	Cont.	34[9]	34[9]	34[9]	45[12]	45[12]
lpm [GPM]	Int.	42[11]	42[11]	50[13]	57[15]	57[15]
Max. Differential Pressure	Cont.	140[2030]	140[2030]	140[2030]	140[2030]	140[2030]
bar [PSI]	Int.	190[2750]	190[2750]	190[2750]	190[2750]	190[2750]
Max. Supply Pressure bar [PSI]		200[2900]	200[2900]	200[2900]	200[2900]	200[2900]
Max. Torque	cont.	5.46[483]	7.1[624]	9.0[796]	12.5[1106]	16.0[1416]
daNm [lb-in]	int.	7.11[60]	9.9[876]	12.7[1120]	17.6[1558]	22.0[1947]
Max. Performance kW [HP]		8.5[11.4]	10.4[13.9]	12.8[17.2]	14.7[19.8]	17.3[23.2]
Min. Starting Torque	cont.	4.4[389]	4.4[111]	7.2[637]	10.0[885]	12.8[1133]
daNm[lb-in]	int.	5.2[460]	6.4[565]	9.8[871]	13.7[1211]	17.1[1515]
Weight, kg [lb]	GFA	5.93[13.07]	6.03[13.3]	6.12[13.5]	6.26[13.8]	6.35[14.0]

Type		GFA100	GFA0130	GFA165	GFA195	GFA230
Displacement cm ³ /rev [in ³ /rev]		98[6.0]	130[8.0]	163[10.0]	195[11.9]	228[13.9]
Max. Speed RPM	Int.	582	438	348	292	328
Max. Oil Flow	Cont.	45[12]	45[12]	45[12]	45[12]	57[15]
lpm [GPM]	Int.	57[15]	57[15]	57[15]	57[15]	75[20]
Max. Differential Pressure	Cont.	140[2030]	140[2030]	140[2030]	140[2030]	120[1740]
bar [PSI]	Int.	190[2750]	190[2750]	190[2750]	190[2750]	165[2400]
Max. Supply Pressure bar [PSI]		200[2900]	200[2900]	200[2900]	200[2900]	200[2900]
Max. Torque	cont.	19.0[1682]	25.5[2257]	31.0[2744]	39.0[3452]	38.0[3363]
daNm [lb-in]	int.	26.4[2337]	35.2[3116]	43.6[3846]	52.8[4673]	51.4[4554]
Max. Performance kW [HP]		17.4[23.4]	17.3[23.2]	17.0[22.8]	17.4[23.4]	17.7[23.8]
Min. Starting Torque	cont.	15.2[1345]	20.4[1806]	24.8[2195]	31.2[2762]	30.4[2691]
daNm [lb-in]	int.	20.5[1819]	27.4[2423]	33.8[2992]	41.1[3637]	41.1[3637]
Weight, kg [lb]	GFA	6.49[14.3]	6.76[14.9]	7.03[15.5]	7.35[16.2]	7.58[16.7]



Specifications

Type		GFA260	GFA295	GFA330	GFA365	GFA390
Displacement cm ³ /rev [in ³ /rev]		260[15.9]	293[17.9]	328[20.0]	370[22.6]	392[24.0]
Max. Speed RPM	Int.	287	256	228	203	191
Max. Oil Flow	Cont.	57[15]	57[15]	57[15]	57[15]	57[15]
lpm [GPM]	Int.	75[20]	75[20]	75[20]	75[20]	75[20]
Max. Differential Pressure	Cont.	110[1595]	100[1450]	100[1450]	95[1378]	85[1233]
bar [PSI]	Int.	155[2250]	145[2100]	135[1950]	125[1825]	120[1740]
Max. Supply Pressure bar [PSI]		200[2900]	200[2900]	200[2900]	200[2900]	200[2900]
Max. Torque	Cont.	40.0[3540]	42.8[3784]	44.3[3926]	46.7[4133]	44.5[3935]
daNm [lb-in]	Int.	55.0[4870]	58.2[5180]	60.0[5312]	64.8[5728]	62.8[5562]
Max. Performance kW [HP]		16.7[22.4]	15.7[21.0]	14.8[19.8]	13.6[18.2]	12.5[16.8]
Min. Starting Torque	Cont.	32.0[2832]	32.8[2903]	33.4[3045]	37.3[3301]	34.8[3080]
daNm [lb-in]	Int.	44.9[3977]	44.5[3939]	45.3[4014]	47.7[4223]	46.2[4090]
Weight, kg [lb]	GFA	7.80[17.2]	8.07[17.8]	8.35[18.4]	8.66[19.1]	8.80[19.4]



Function Diagrams

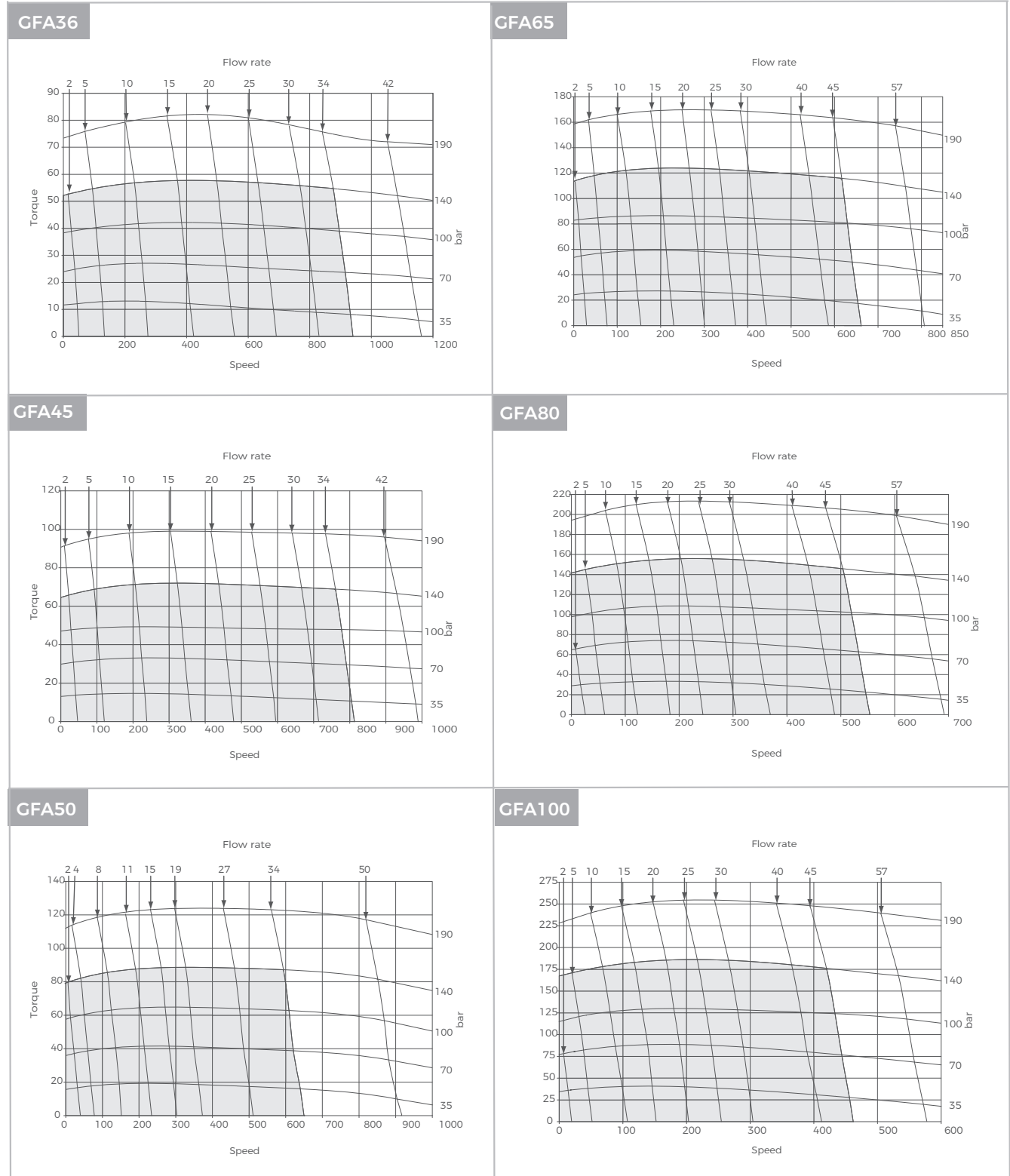

The function diagrams data is for average performance of randomly selected motors at backpressure. 5–10 bar [72.5–145 PSI] and oil with viscosity of 32mm²/s [150 SUS] at 50°C [122°F].

Function Diagrams

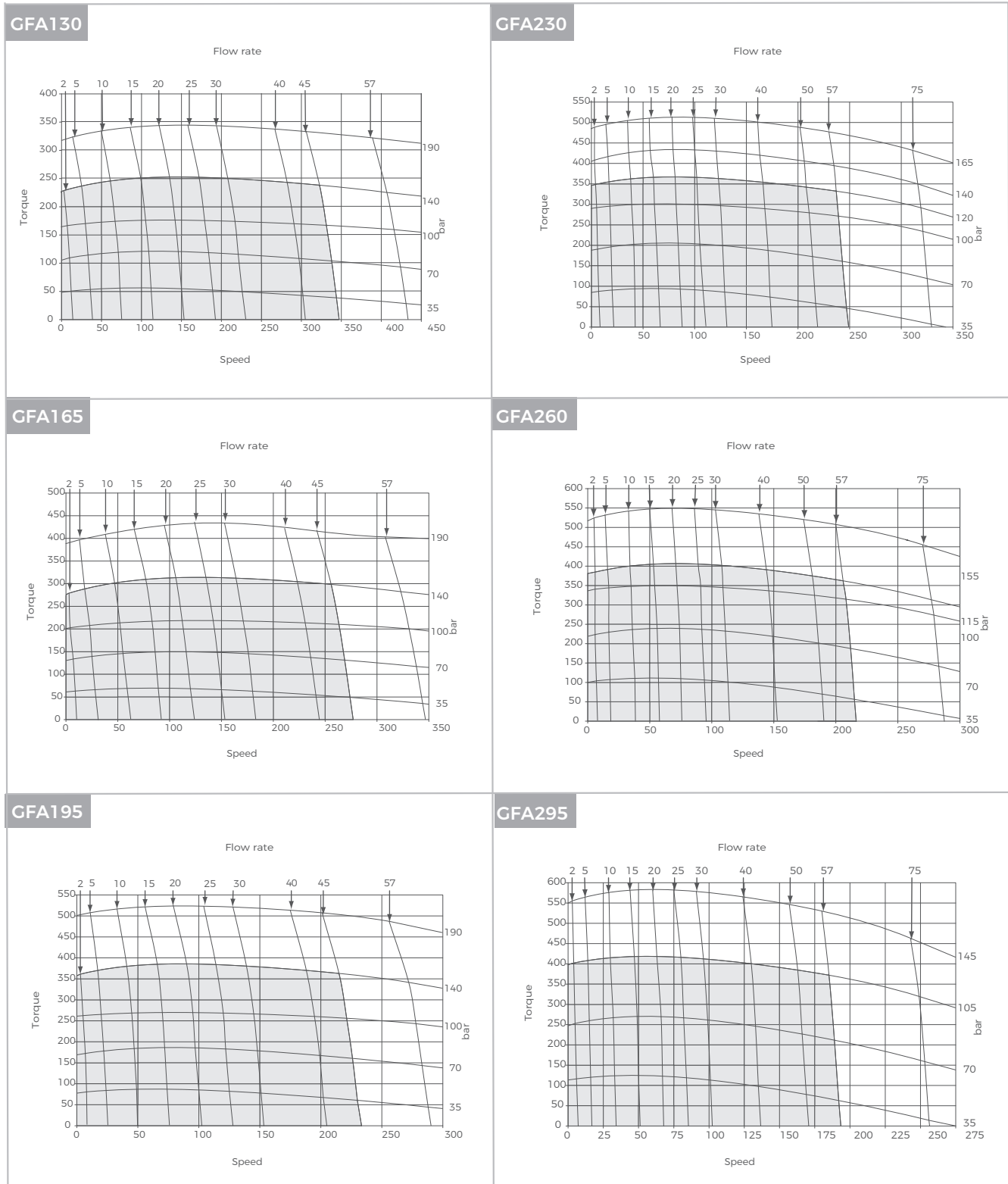

The function diagrams data is for average performance of randomly selected motors at backpressure. 5–10 bar [72.5–145 PSI] and oil with viscosity of 32mm²/s [150 SUS] at 50°C [122°F].

Function Diagrams

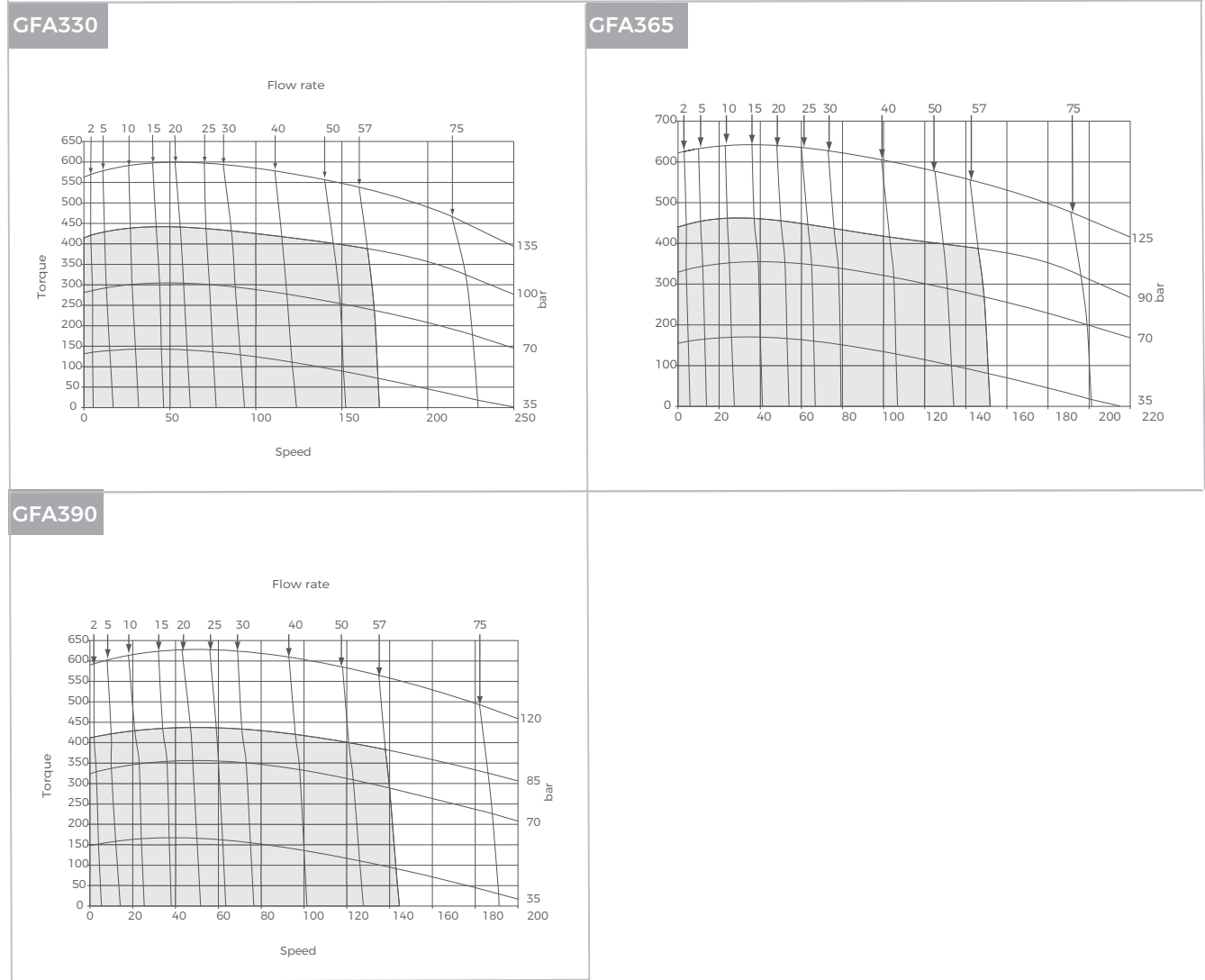

The function diagrams data is for average performance of randomly selected motors at backpressure. 5–10 bar [72.5–145 PSI] and oil with viscosity of 32mm²/s [150 SUS] at 50°C [122°F].

GFA Dimensions and Mountings

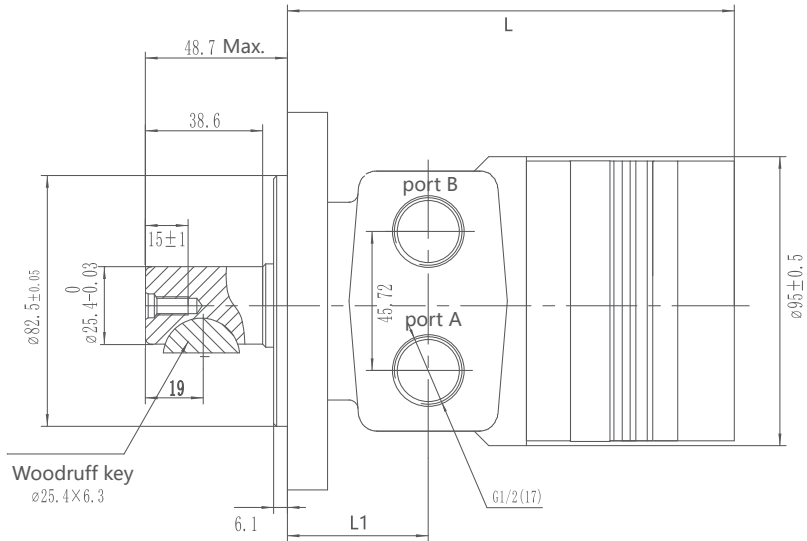

Model	L(mm)
GFA36	135
GFA45	136
GFA50	138
GFA65	141
GFA80	144
GFA100	147
GFA130	154
GFA165	160
GFA195	166
GFA230	173
GFA260	179
GFA295	185
GFA330	192
GFA365	200
GFA390	205

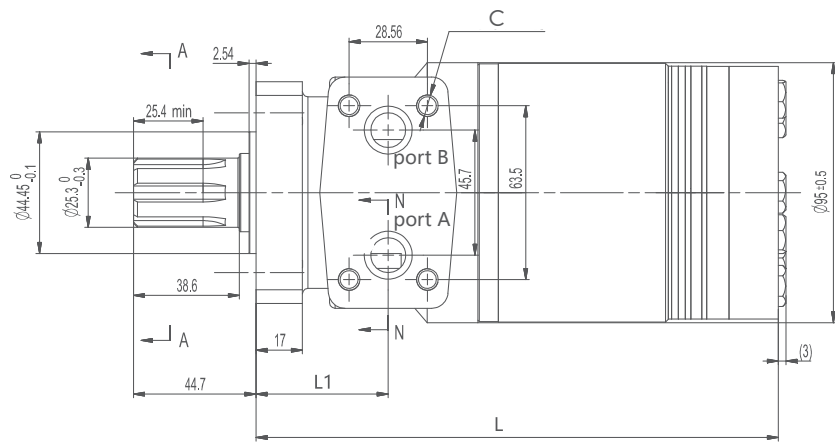

Mounting	G7 (depth)	U9 (depth)	UA (depth)	U3 (depth)	G8 (depth)	D1 (depth)	D2 (depth)
P(A, B)	G1/2(15)	7/8-14 O-ring(17)	1/2-14NPTF(15)	3/4-16 O-ring(15)	PT(RC)1/2(15)	Ø10	Ø10
T	G1/4(12)	7/16-20UNF(12)	7/16-20UNF(12)	7/16-20UNF(12)	PT(RC)1/4(9.7)	7/16-20UNF(12)	G1/4(12)
C	—	—	—	—	—	4-5/16-18UNC(13)	4-M8(13)

GFA Dimensions and Mountings

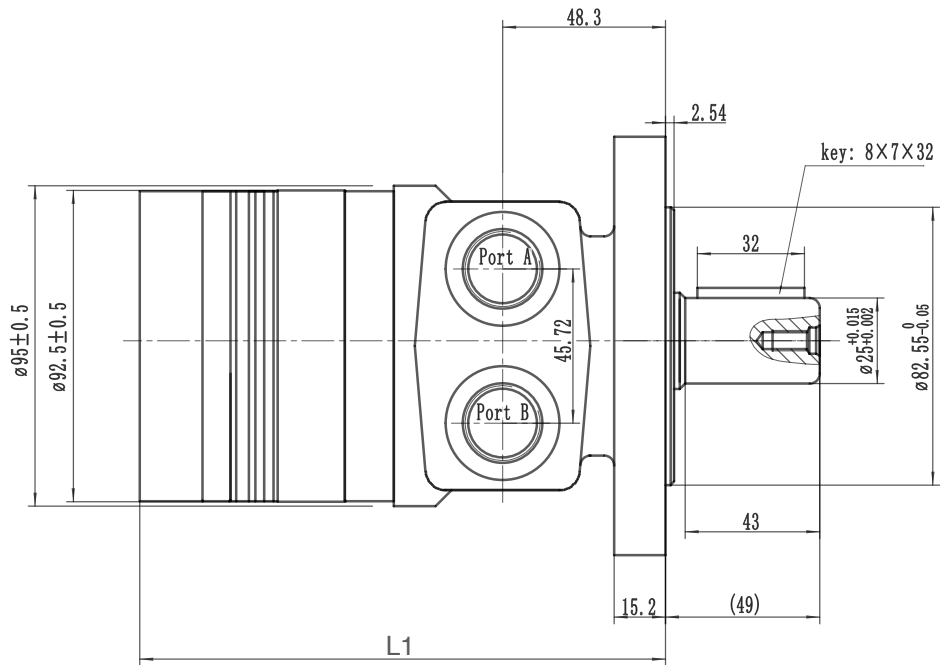

Model	L1(mm)	L2(mm)
GFA36	144	140
GFA45	145	141
GFA50	147	143
GFA65	150	146
GFA80	153	149
GFA100	165	158
GFA130	163	159
GFA165	169	165
GFA195	175	171
GFA230	182	178
GFA260	188	184
GFA295	194	189
GFA330	201	197
GFA365	209	205
GFA390	214	210

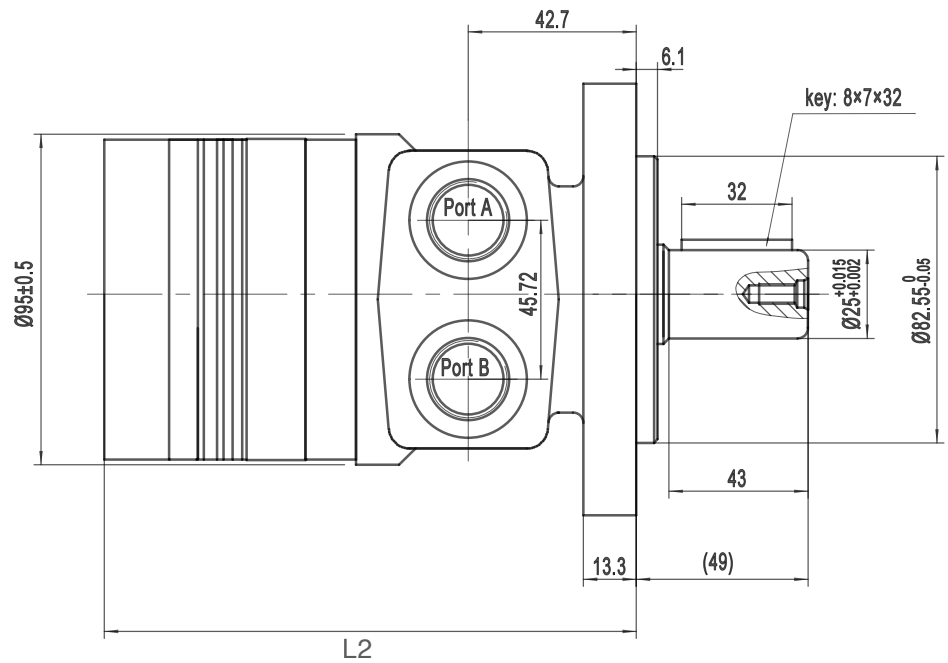

Mounting	G7 (depth)	U9 (depth)	UA (depth)	U3 (depth)	G8 (depth)	D1 (depth)	D2 (depth)
P(A, B)	G1/2(15)	7/8-14 O-ring(17)	1/2-14NPTF(15)	3/4-16 O-ring(15)	PT(RC)1/2(15)	∅10	∅10
T	G1/4(12)	7/16-20UNF(12)	7/16-20UNF(12)	7/16-20UNF(12)	PT(RC)1/4(9.7)	7/16-20UNF(12)	G1/4(12)
C	—	—	—	—	—	4-5/16-18UNC(13)	4-M8(13)

GFA Wheel Motor Dimensions and Mountings

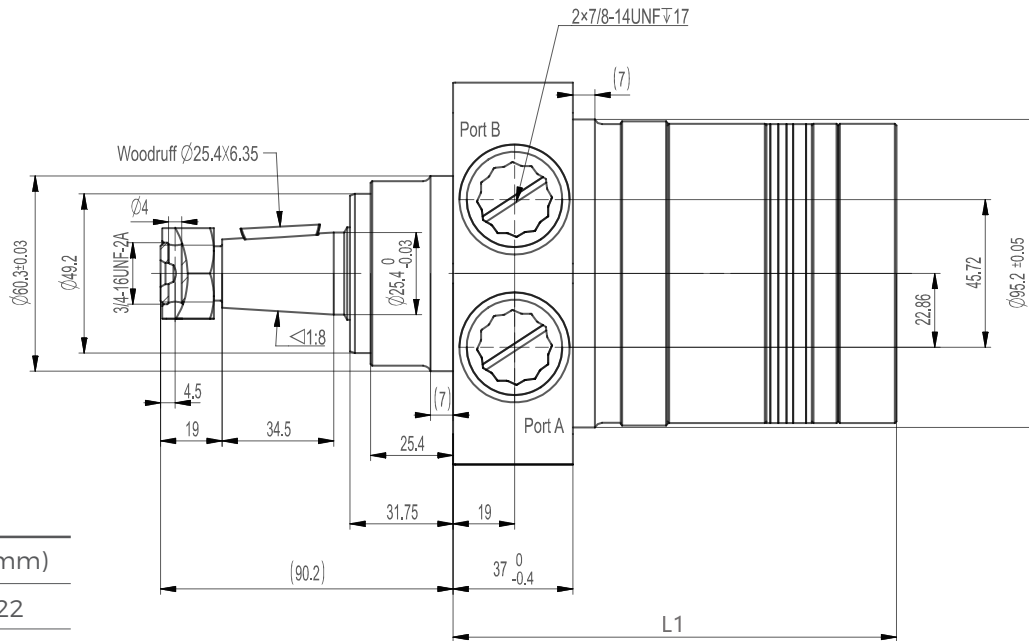

Model	L1(mm)
GFA36	122
GFA45	123
GFA50	125
GFA65	118
GFA80	121
GFA100	124
GFA130	131
GFA165	137
GFA195	143
GFA230	150
GFA260	156
GFA295	162
GFA330	169
GFA365	177
GFA390	182

Mounting	G7 (depth)	U9 (depth)	UA (depth)	U3 (depth)	G8 (depth)	D1 (depth)	D2 (depth)
P(A, B)	G1/2(15)	7/8-14 O-ring(17)	1/2-14NPTF(15)	3/4-16 O-ring(15)	PT(RC)1/2(15)	Ø10	Ø10
T	G1/4(12)	7/16-20UNF(12)	7/16-20UNF(12)	7/16-20UNF(12)	PT(RC)1/4(9.7)	7/16-20UNF(12)	G1/4(12)
C	—	—	—	—	—	4-5/16-18UNC(13)	4-M8(13)

GFA Dimensions and Mountings

Model	L1(mm)	L2(mm)
GFA36	136	141
GFA45	137	142
GFA50	139	144
GFA65	142	147
GFA80	145	150
GFA100	148	153
GFA130	155	160
GFA165	161	166
GFA195	167	172
GFA230	174	179
GFA260	180	185
GFA295	186	191
GFA330	193	198
GFA365	201	206
GFA390	206	211

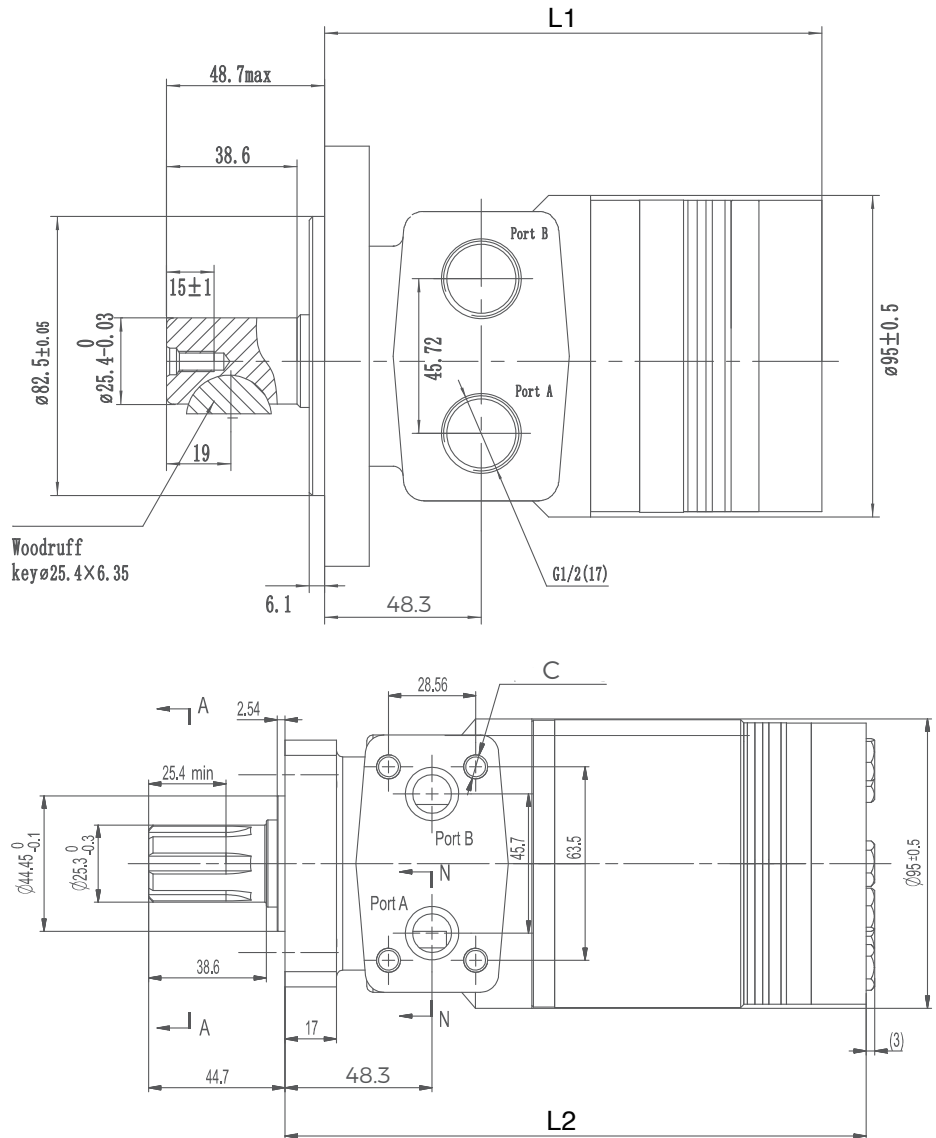

Mounting	G7 (depth)	U9 (depth)	UA (depth)	U3 (depth)	G8 (depth)	D1 (depth)	D2 (depth)
P(A, B)	G1/2(15)	7/8-14 O-ring(17)	1/2-14NPTF(15)	3/4-16 O-ring(15)	PT(RC)1/2(15)	Ø10	Ø10
T	G1/4(12)	7/16-20UNF(12)	7/16-20UNF(12)	7/16-20UNF(12)	PT(RC)1/4(9.7)	7/16-20UNF(12)	G1/4(12)
C	—	—	—	—	—	4-5/16-18UNC(13)	4-M8(13)

GFA Flange Covers Dimensions

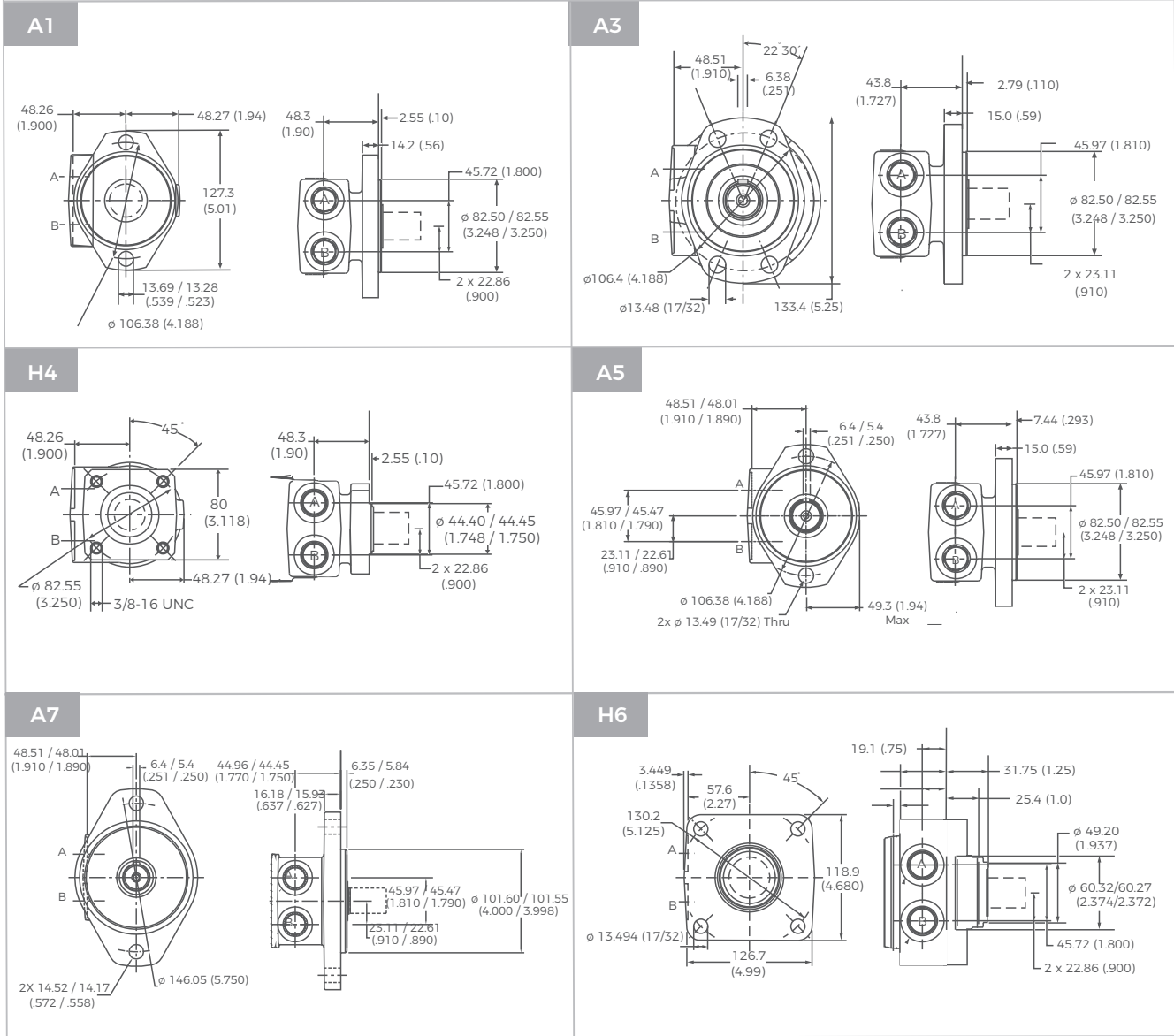

GFA Shafts Dimensions

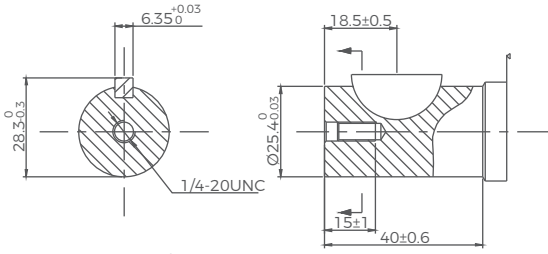
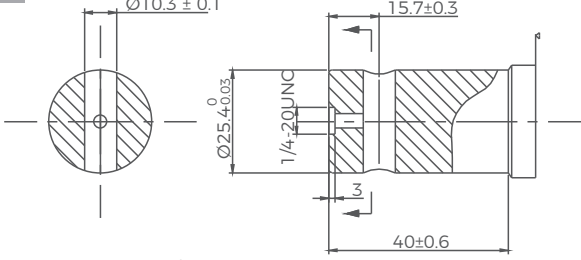
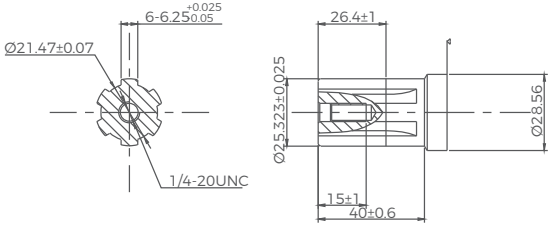
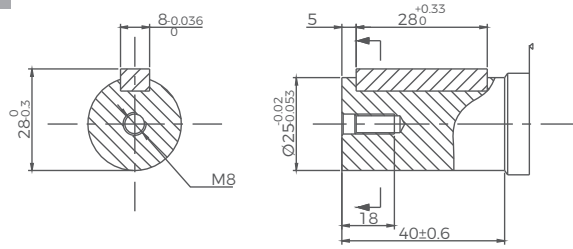
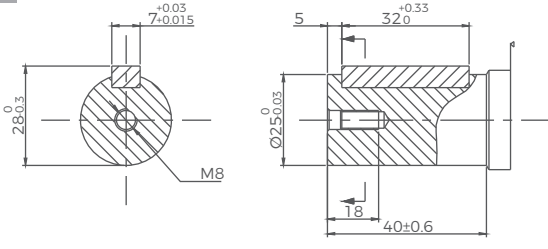
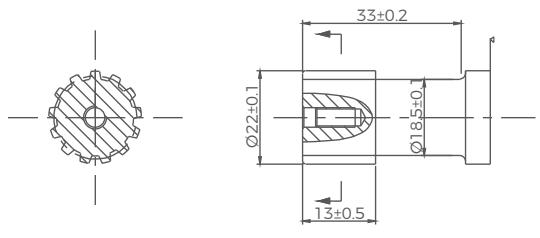
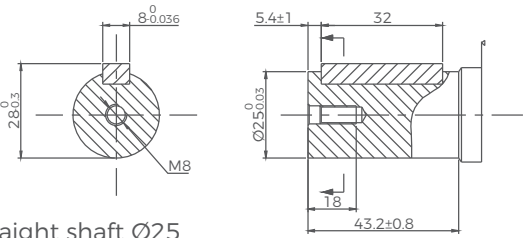
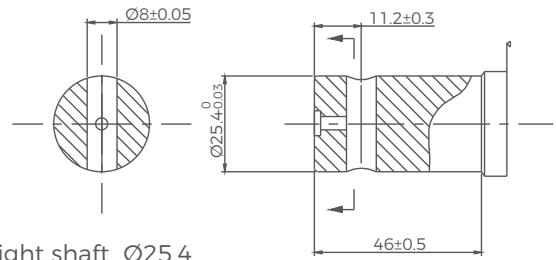
<p>S6</p>  <p>Straight shaft $\varnothing 25.4$ Woodruff key $\varnothing 25.4 \times 6.35$</p>	<p>S9</p>  <p>Straight shaft $\varnothing 25.4$ Pin hole $\varnothing 10.3$</p>
<p>R4</p>  <p>Splined shaft SAE 6B</p>	<p>SC</p>  <p>Straight shaft $\varnothing 25$ Parallel key 8 x 7 x 28</p>
<p>SD</p>  <p>Straight shaft $\varnothing 25$ Parallel key 7 x 7 x 32</p>	<p>R5</p>  <p>Splined shaft tooth 13-DP 16/32</p>
<p>S7</p>  <p>Straight shaft $\varnothing 25$ Parallel key 8 x 7 x 32</p>	<p>SA</p>  <p>Straight shaft $\varnothing 25.4$ Pin hole $\varnothing 8$</p>

GFA Shafts Dimensions

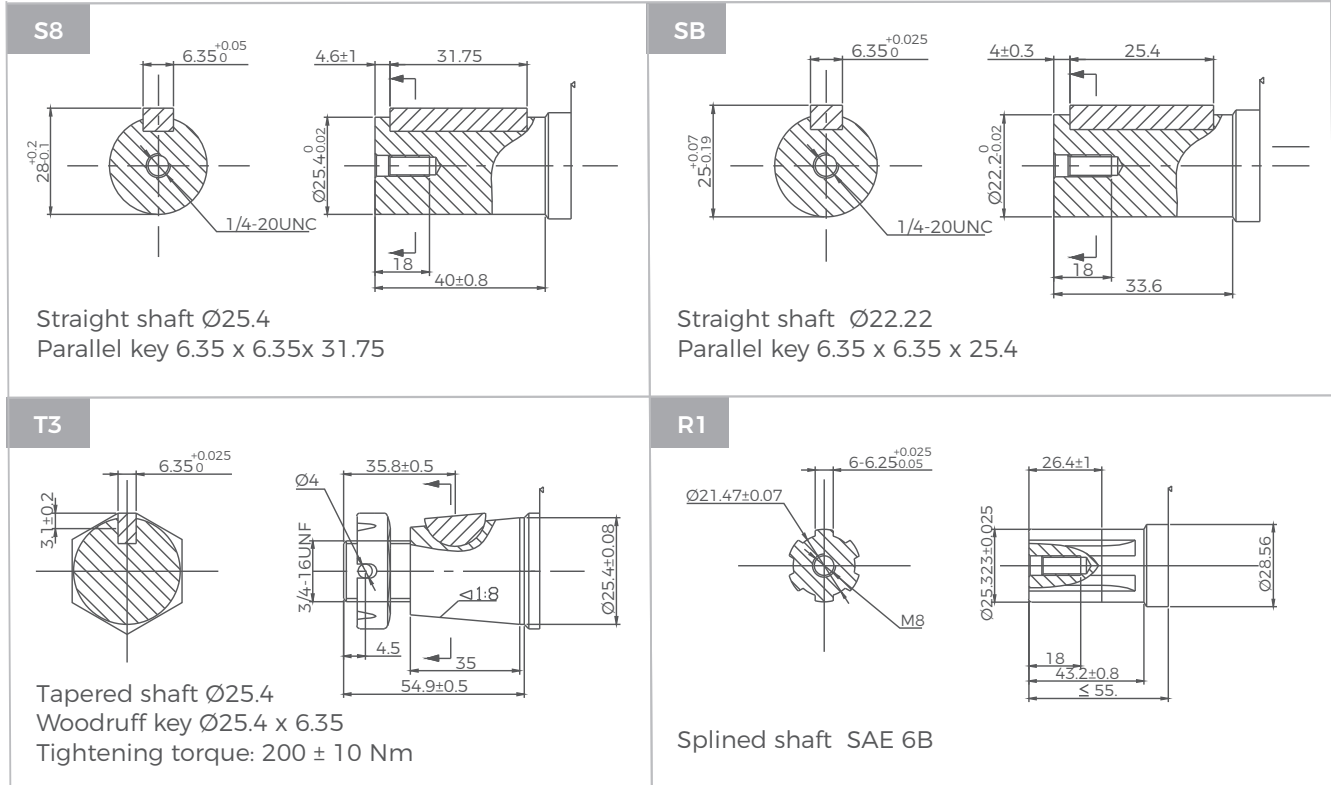

GFB Series Hydraulic Motors

Options

- Flange connection
- Motor with needle roller bearing
- Speed sensing
- Side and rear ports
- Shaft seal for high and low pressure
- Straight, splined and tapered shafts
- Metric and BSPP ports
- Other special features

Applications

- Conveyors
- Feeding machiners
- Metal working machines
- Textile machines
- Agricultural machines
- Food industries
- Lawn mower







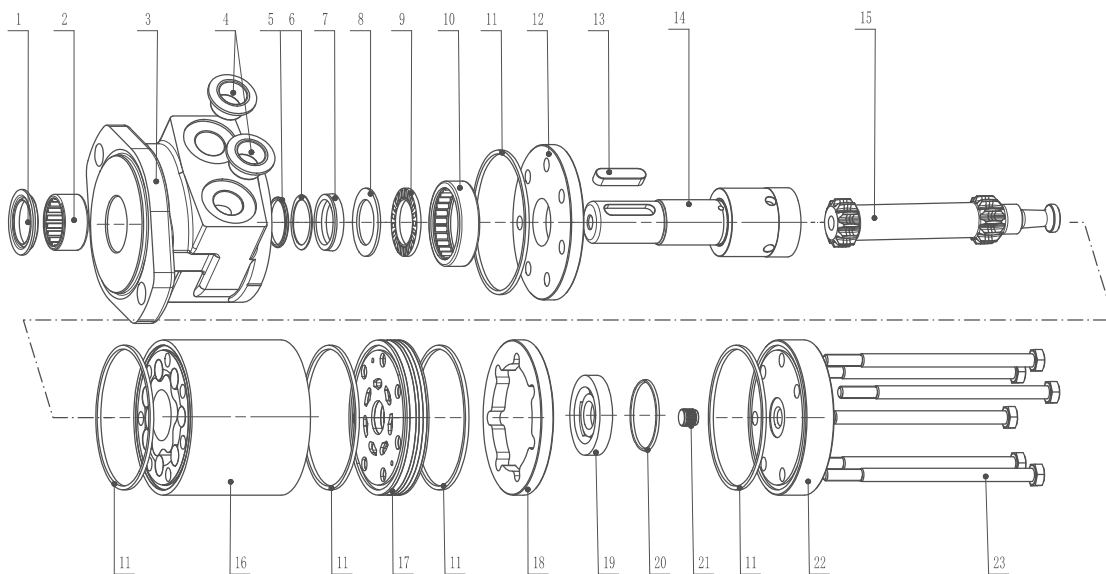





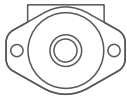







General

Max. Displacement	cm ³ /rev [in ³ /rev]	392 [24.0]
Max. Speed	RPM	1141
Max. Torque	daNm [lb-in]	cont.:44,5 [3935] int.:62,8 [5562]
Max. Output	kW [HP]	12.5 [16.8]
Max. Pressure Drop	bar [PSI]	cont.: 140 [2030] int.: 190 [2750]
Max. Oil Flow	lpm [GPM]	75 [20.0]
Pressure fluid		Mineral based-HLP (DIN 51524) or HM (ISO 6743/4)
Temperature Range	°C [°F]	-40–140 [-104–284]
Optimal Viscosity range	mm ² /s [SUS]	20–75 [98–347]
Filtration		ISO code 20/16 (Min. recommended fluid filtration of 25 microns)



- | | | | | |
|---------------------------|---------------------------|--------------------------|---------------------|---------------------|
| 1 Dust ring | 6 Shaft seal gasket | 11 Rectangular seal ring | 16 Rotor and stator | 21 Positioning pins |
| 2 Needle roller bearings | 7 Shaft seal | 12 Spacer | 17 Welding plate | 22 Rear cover |
| 3 Housing | 8 Bearing retaining ring | 13 Flat key | 18 Spacer bush | 23 Screw |
| 4 Ports plug | 9 Flat bearing | 14 Output shaft | 19 Thrust plate | |
| 5 Shaft seal support ring | 10 Needle roller bearings | 15 Transmission shaft | 20 Seal ring | |

Ordering Code

GFB SERIES		DISP	FLANGE	SHAFT	PORTS	ROTATION	PAINT	FUNCTION
CODE	DISP cm/rev [in/rev]		CODE	FLANGE	CODE	SHAFT	CODE	ROTATION
036	36 [2.2]		A1	2-Hole SAE A pilot Ø82.5×2.55 	S6	Ø25.4 woodruff key Ø25.4×6.35 	A	Standard
045	41 [2.5]				R4	Ø25.4, splined tooth SAE 6B 1/4-20UNC 	R	Opposite
050	49 [3.0]				S7	Ø25 parallel key 8×7×32 		
065	65 [4.0]		A3	4-Hole SAE A pilot Ø82.5×2.79 	S8	Ø25.4 parallel key 6.35×6.35×31.75 	CODE	PAINT
080	82 [5.0]				S9	Ø25.4, pin hole Ø10.3 	A	No paint
100	98 [6.0]				SA	Ø25.4, pin hole Ø8 	B	Blue
130	130 [8.0]		H4	4-3/8-16UNC square pilot Ø44.4×2.55 	SB	Ø22.22 parallel key 6.35×6.35×25.4 	C	Black
165	163 [10.0]				R5	Ø22.22 splined tooth 13-DP 16/32 	S	Silver grey
195	195 [11.9]				T3	Tapered Ø25.4 woodruff key Ø25.4×6.35 	CODE	FUNCTION
230	228 [13.9]		A5	2-Hole SAE A pilot Ø82.5×7.44 	SC	Ø25 parallel key 8×7×28 	A	Standard
260	260 [15.9]				SD	Ø25 parallel key 7×7×32 	N	Big radial force
290	293 [17.9]		A7	2-Hole SAE B pilot Ø101.6×6.35 	R1	Ø25.4 splined tooth SAE 6B 	D	No case drain
330	328 [20.0]						F	Free running
365	370 [22.6]						L	Low speed
390	392 [24.0]		H6	4-Hole wheel pilot Ø60.32×31.75 			V	High temp.
					CODE	PORTS	S	Low temp.
					G7	G1/2, G14		
					U9	7/8-14 UNF O-ring, 7/16-20UNF		
					UA	1/2-14 NPTF, 7/16-20UNF		
					U3	3/4-16 O-ring, 7/16-20UNF		
					G8	PT(Rc) 1/2, PT(Rc) 1/4		
					D1	Ø10 O-ring, 7/16-20UNF manifold 4×5/16-18UNC		
					D2	Ø10 O-ring, G1/4 manifold 4×M8		

GFB Specifications

Type		GFB36	GFB45	GFB50	GFB65	GFB80
Displacement cm ³ /rev [in ³ /rev]		36[2.2]	41[2.5]	49[3.0]	65[4.0]	82[5.0]
Max. Speed RPM	Int.	1141	1024	1020	877	695
Max. Oil Flow	Cont.	34[9]	34[9]	34[9]	45[12]	45[12]
lpm [GPM]	Int.	42[11]	42[11]	50[13]	57[15]	57[15]
Max. Differential Pressure	Cont.	140[2030]	140[2030]	140[2030]	140[2030]	140[2030]
bar [PSI]	Int.	190[2750]	190[2750]	190[2750]	190[2750]	190[2750]
Max. Supply Pressure bar [PSI]		200[2900]	200[2900]	200[2900]	200[2900]	200[2900]
Max. Torque	cont.	5.46[483]	7.1[624]	9.0[796]	12.5[1106]	16.0[1416]
daNm [lb-in]	int.	7.11[60]	9.9[876]	12.7[1120]	17.6[1558]	22.0[1947]
Max. Performance kW [HP]		8.5[11.4]	10.4[13.9]	12.8[17.2]	14.7[19.8]	17.3[23.2]
Min. Starting Torque	cont.	4.4[389]	4.4[1111]	7.2[637]	10.0[885]	12.8[1133]
daNm[lb-in]	int.	5.2[460]	6.4[565]	9.8[871]	13.7[1211]	17.1[1515]
Weight, kg [lb]	GFB	5.93[13.07]	6.03[13.3]	6.12[13.5]	6.26[13.8]	6.35[14.0]

Type		GFB100	GFB130	GFB165	GFB195	GFB230
Displacement cm ³ /rev [in ³ /rev]		98[6.0]	130[8.0]	163[10.0]	195[11.9]	228[13.9]
Max. Speed RPM	Int.	582	438	348	292	328
Max. Oil Flow	Cont.	45[12]	45[12]	45[12]	45[12]	57[15]
lpm [GPM]	Int.	57[15]	57[15]	57[15]	57[15]	75[20]
Max. Differential Pressure	Cont.	140[2030]	140[2030]	140[2030]	140[2030]	120[1740]
bar [PSI]	Int.	190[2750]	190[2750]	190[2750]	190[2750]	165[2400]
Max. Supply Pressure bar [PSI]		200[2900]	200[2900]	200[2900]	200[2900]	200[2900]
Max. Torque	cont.	19.0[1682]	25.5[2257]	31.0[2744]	39.0[3452]	38.0[3363]
daNm [lb-in]	int.	26.4[2337]	35.2[3116]	43.6[3846]	52.8[4673]	51.4[4554]
Max. Performance kW [HP]		17.4[23.4]	17.3[23.2]	17.0[22.8]	17.4[23.4]	17.7[23.8]
Min. Starting Torque	cont.	15.2[1345]	20.4[1806]	24.8[2195]	31.2[2762]	30.4[2691]
daNm [lb-in]	int.	20.5[1819]	27.4[2423]	33.8[2992]	41.1[3637]	41.1[3637]
Weight, kg [lb]	GFB	6.49[14.3]	6.76[14.9]	7.03[15.5]	7.35[16.2]	7.58[16.7]

Specifications

Type		GFB260	GFB295	GFB330	GFB365	GFB390
Displacement cm ³ /rev [in ³ /rev]		260[15.9]	293[17.9]	328[20.0]	370[22.6]	392[24.0]
Max. Speed RPM	Int.	287	256	228	203	191
Max. Oil Flow	Cont.	57[15]	57[15]	57[15]	57[15]	57[15]
lpm [GPM]	Int.	75[20]	75[20]	75[20]	75[20]	75[20]
Max. Differential Pressure	Cont.	110[1595]	100[1450]	100[1450]	95[1378]	85[1233]
bar [PSI]	Int.	155[2250]	145[2100]	135[1950]	125[1825]	120[1740]
Max. Supply Pressure bar [PSI]		200[2900]	200[2900]	200[2900]	200[2900]	200[2900]
Max. Torque	Cont.	40.0[3540]	42.8[3784]	44.3[3926]	46.7[4133]	44.5[3935]
daNm [lb-in]	Int.	55.0[4870]	58.2[5180]	60.0[5312]	64.8[5728]	62.8[5562]
Max. Performance kW [HP]		16.7[22.4]	15.7[21.0]	14.8[19.8]	13.6[18.2]	12.5[16.8]
Min. Starting Torque	Cont.	32.0[2832]	32.8[2903]	33.4[3045]	37.3[3301]	34.8[3080]
daNm [lb-in]	Int.	44.9[3977]	44.5[3939]	45.3[4014]	47.7[4223]	46.2[4090]
Weight, kg [lb]	GFB	7.80[17.2]	8.07[17.8]	8.35[18.4]	8.66[19.1]	8.80[19.4]



Function Diagrams

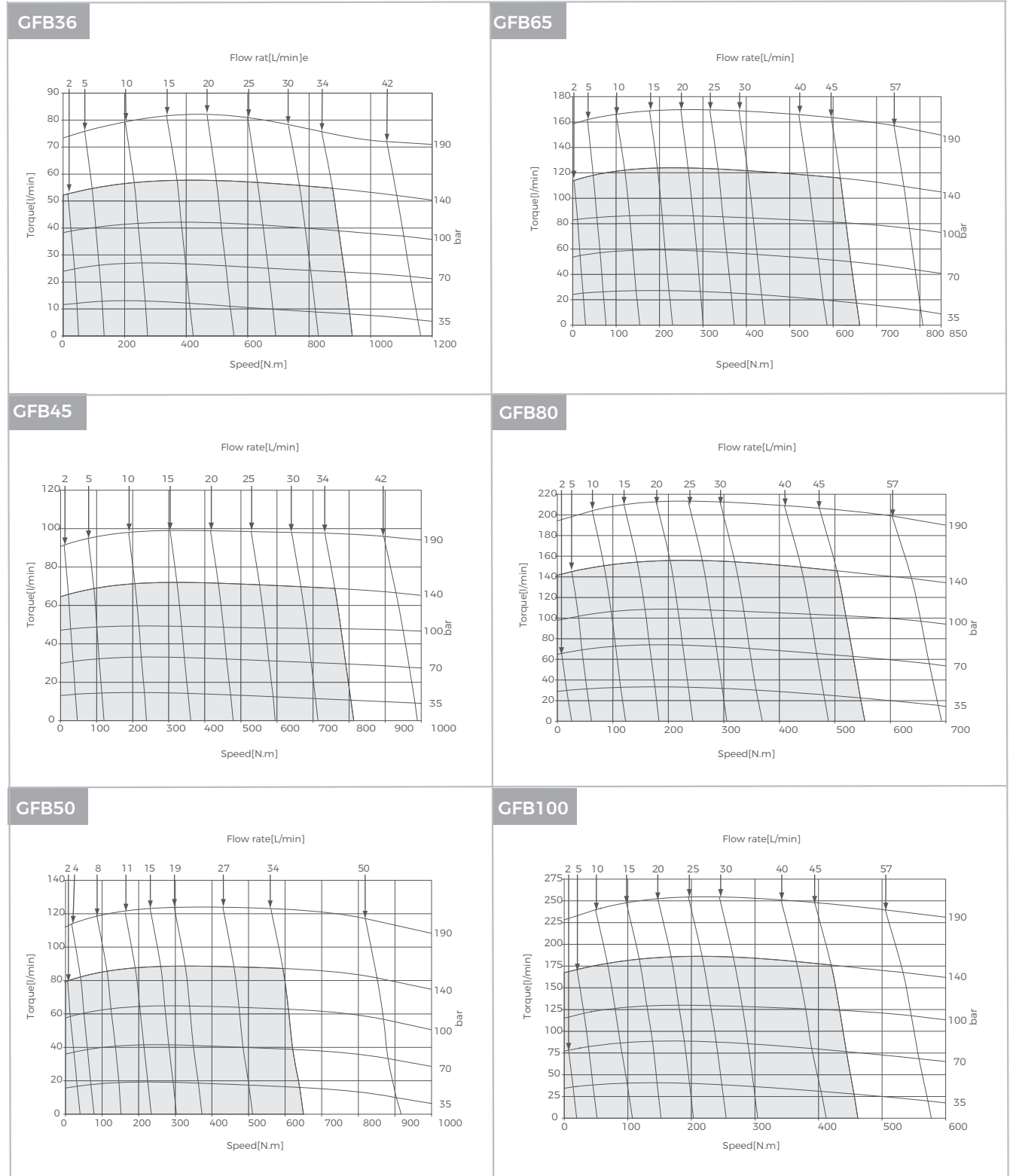

The function diagrams data is for average performance of randomly selected motors at backpressure. 5–10 bar [72.5–145 PSI] and oil with viscosity of 32mm²/s [150 SUS] at 50°C [122°F].



Function Diagrams

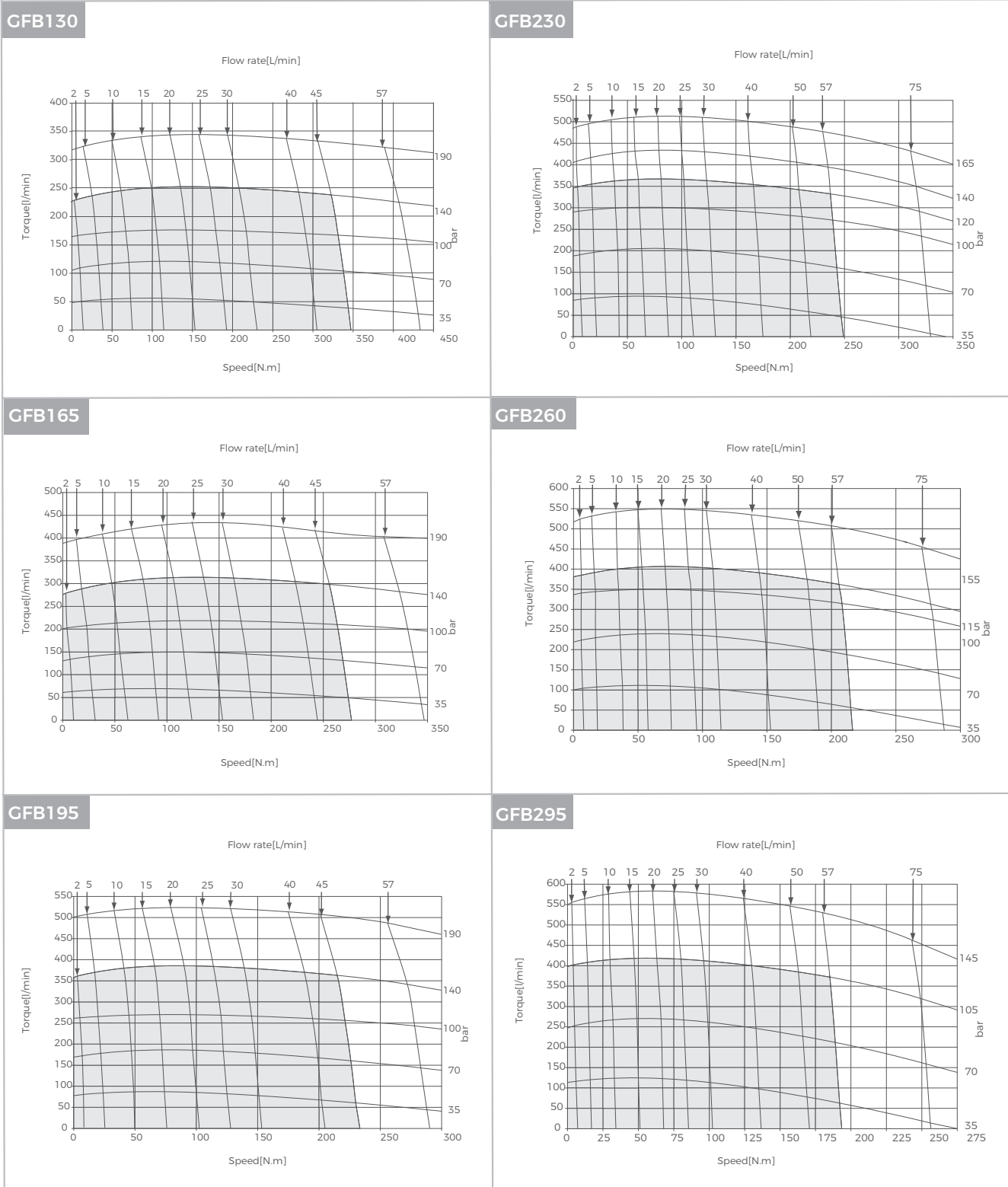

The function diagrams data is for average performance of randomly selected motors at backpressure. 5–10 bar [72.5–145 PSI] and oil with viscosity of 32mm²/s [150 SUS] at 50°C [122°F].

Function Diagrams

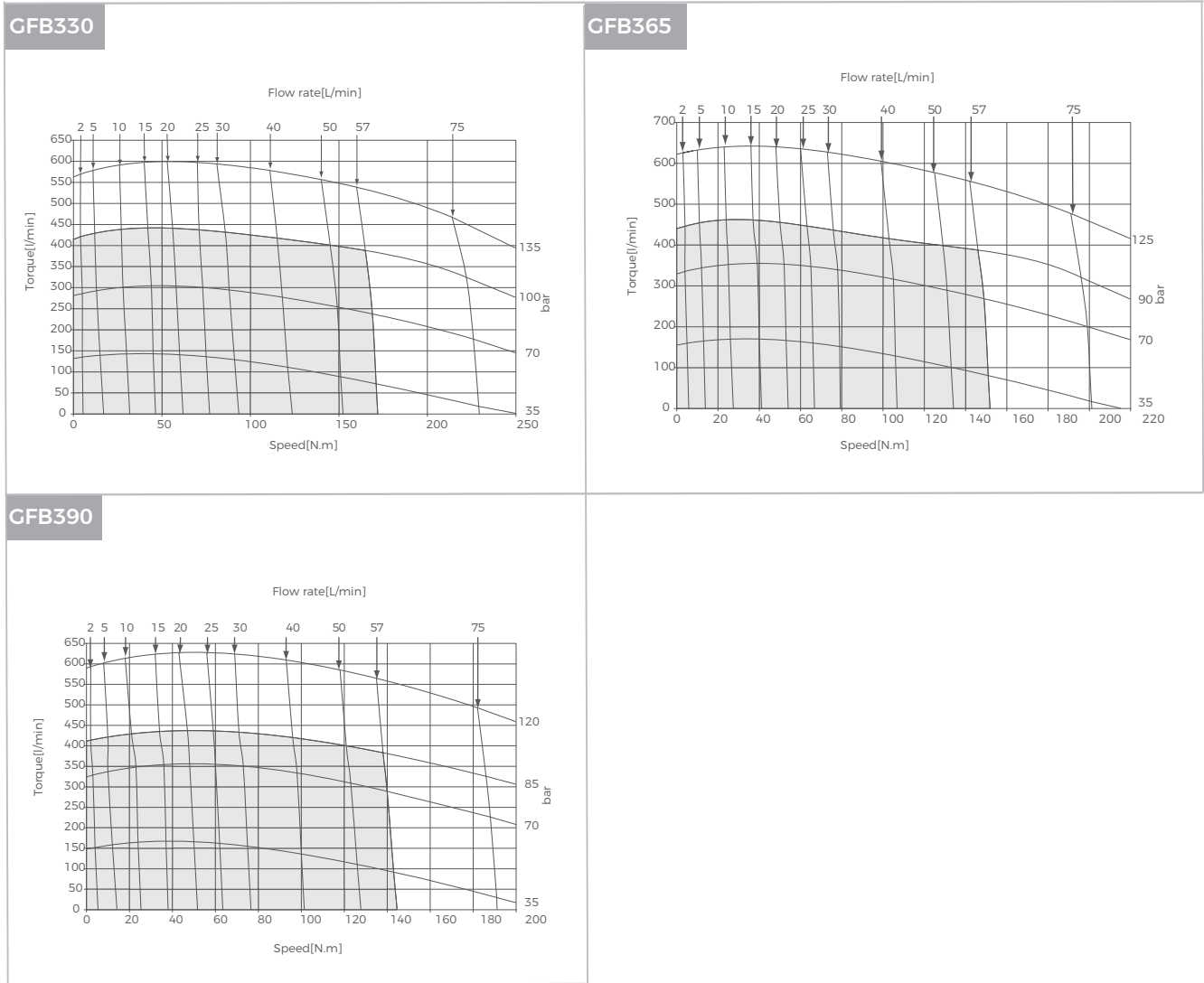

The function diagrams data is for average performance of randomly selected motors at backpressure. 5–10 bar [72.5–145 PSI] and oil with viscosity of 32mm²/s [150 SUS] at 50°C [122°F].

GFB Dimensions and Mountings

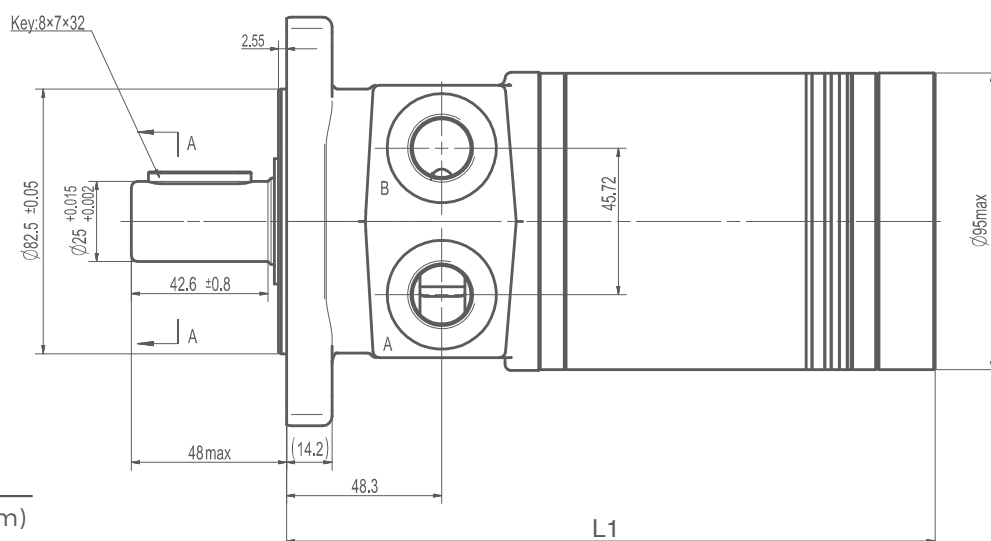

Model	L1(mm)	L2(mm)
GFB 36	132	134
GFB 45	133	135
GFB 50	135	137
GFB 65	139	140
GFB 80	141	143
GFB 100	144	146
GFB 130	151	153
GFB 165	157	159
GFB 195	163	165
GFB 230	170	172
GFB 260	176	178
GFB 295	182	184
GFB 330	189	191
GFB 365	197	199
GFB 390	202	204

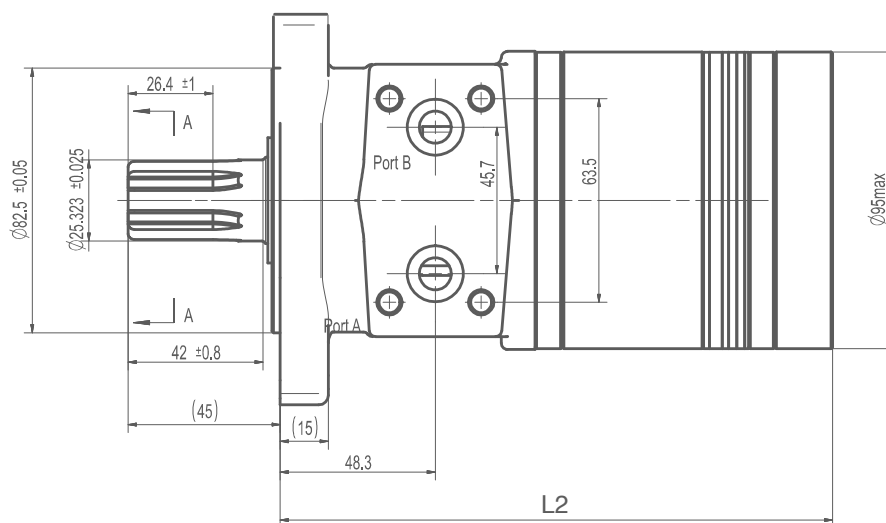

Mounting	G7 (depth)	U9 (depth)	UA (depth)	U3 (depth)	G8 (depth)	D1 (depth)	D2 (depth)
P(A, B)	G1/2(15)	7/8-14 O-ring(17)	1/2-14NPTF(15)	3/4-16 O-ring(15)	PT(RC)1/2(15)	Ø10	Ø10
T	G1/4(12)	7/16-20UNF(12)	7/16-20UNF(12)	7/16-20UNF(12)	PT(RC)1/4(9.7)	7/16-20UNF(12)	G1/4(12)
C	—	—	—	—	—	4-5/16-18UNC(13)	4-M8(13)

GFB Dimensions and Mountings

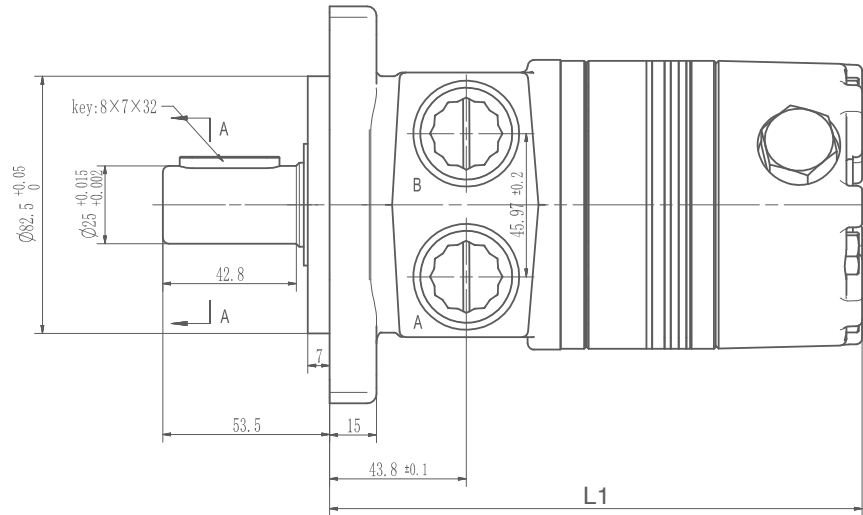

Model	L1(mm)	L2(mm)
GFB 36	159	136
GFB 45	160	137
GFB 50	162	139
GFB 65	165	142
GFB 80	168	145
GFB 100	171	148
GFB 130	178	155
GFB 165	184	161
GFB 195	190	167
GFB 230	197	174
GFB 260	203	180
GFB 295	209	186
GFB 330	216	193
GFB 365	224	201
GFB 390	229	206

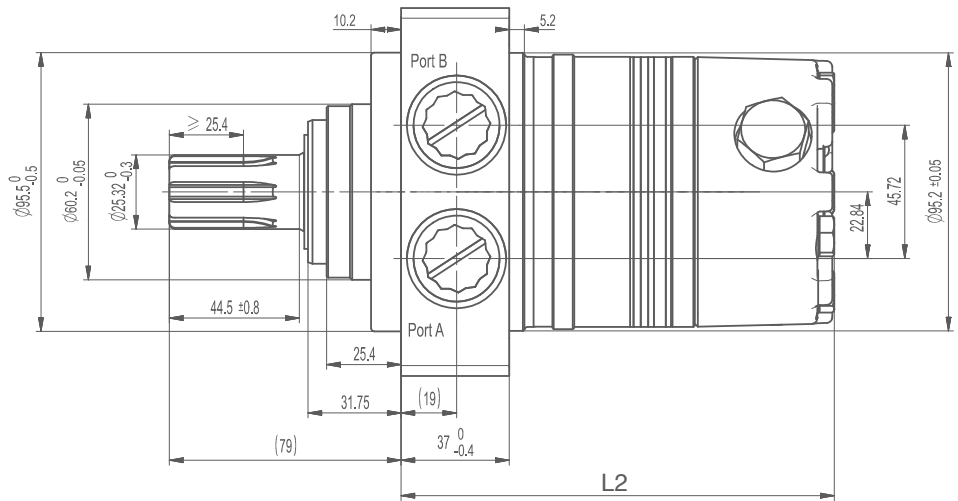

Mounting	G7 (depth)	U9 (depth)	UA (depth)	U3 (depth)	G8 (depth)	D1 (depth)	D2 (depth)
P(A, B)	G1/2(15)	7/8-14 O-ring(17)	1/2-14NPTF(15)	3/4-16 O-ring(15)	PT(RC)1/2(15)	Ø10	Ø10
T	G1/4(12)	7/16-20UNF(12)	7/16-20UNF(12)	7/16-20UNF(12)	PT(RC)1/4(9.7)	7/16-20UNF(12)	G1/4(12)
C	—	—	—	—	—	4-5/16-18UNC(13)	4-M8(13)

GFB Flange Covers Dimensions

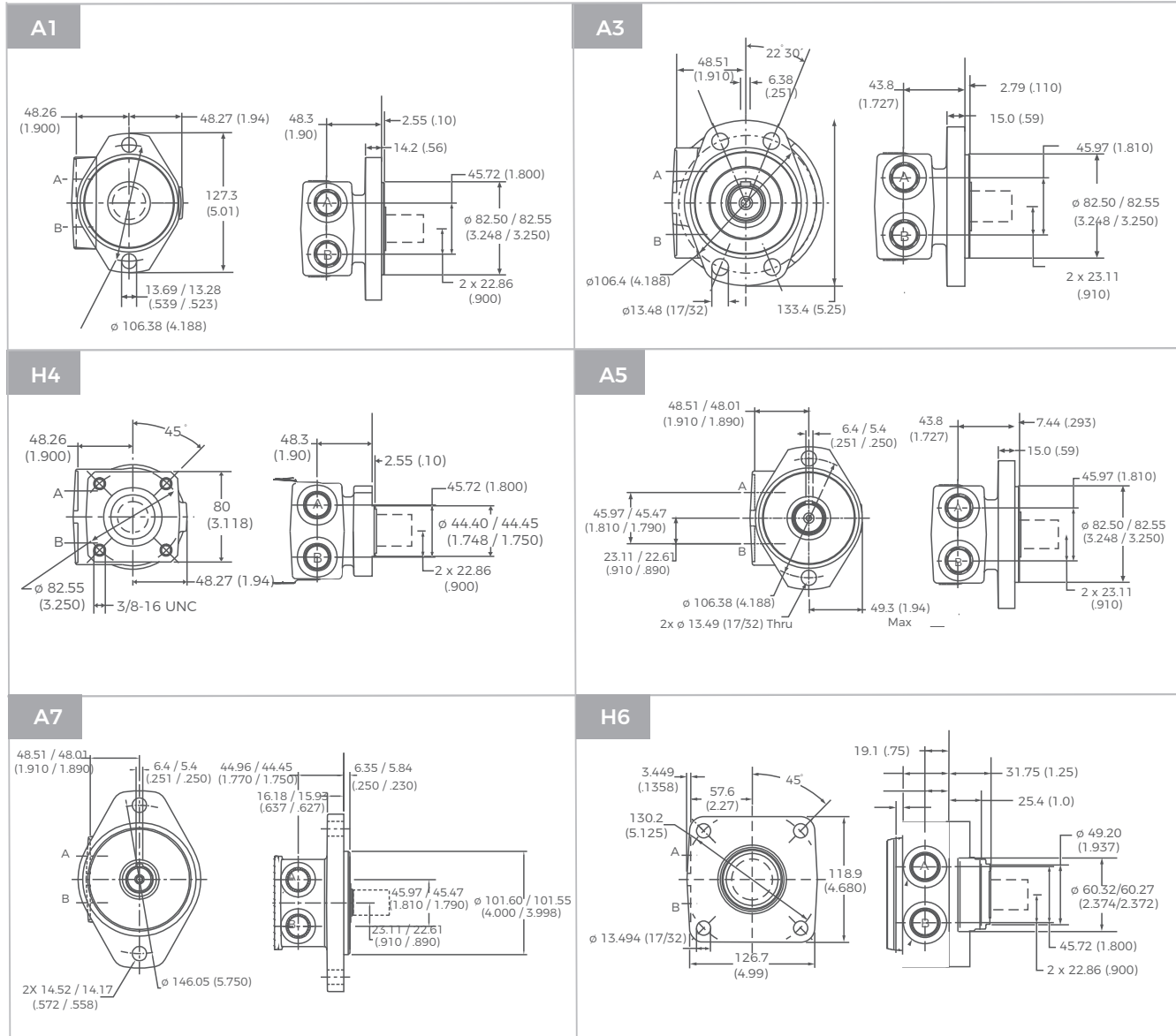

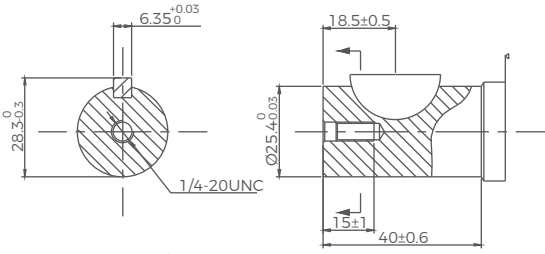
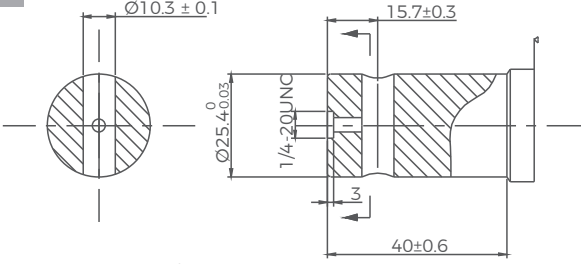
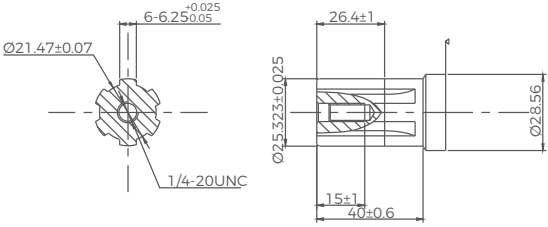
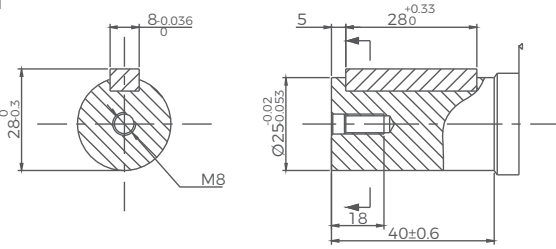
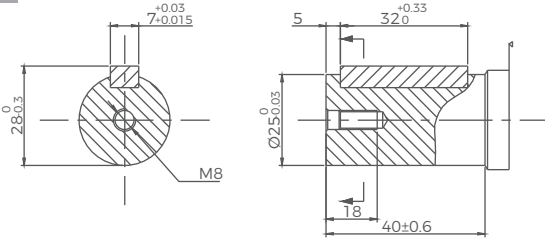
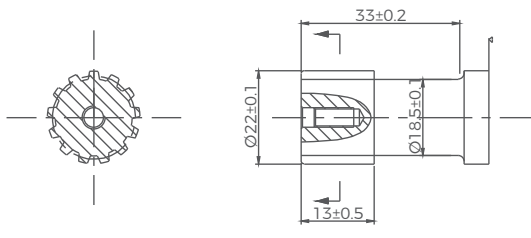
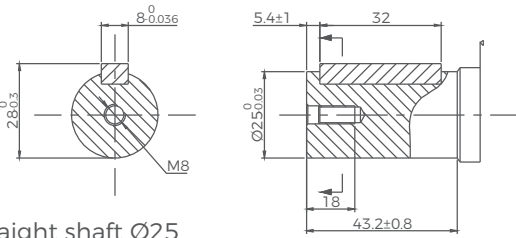
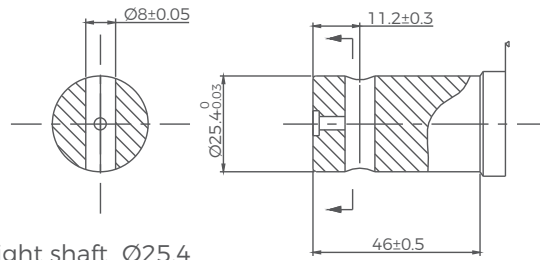

GFB Shafts Dimensions

<p>S6</p>  <p>Straight shaft $\varnothing 25.4$ Woodruff key $\varnothing 25.4 \times 6.35$</p>	<p>S9</p>  <p>Straight shaft $\varnothing 25.4$ Pin hole $\varnothing 10.3$</p>
<p>R4</p>  <p>Splined shaft SAE 6B</p>	<p>SC</p>  <p>Straight shaft $\varnothing 25$ Parallel key 8 x 7 x 28</p>
<p>SD</p>  <p>Straight shaft $\varnothing 25$ Parallel key 7 x 7 x 32</p>	<p>R5</p>  <p>Splined shaft 13-DP 16/32</p>
<p>S7</p>  <p>Straight shaft $\varnothing 25$ Parallel key 8 x 7 x 32</p>	<p>SA</p>  <p>Straight shaft $\varnothing 25.4$ Pin hole $\varnothing 8$</p>

GFB Shafts Dimensions

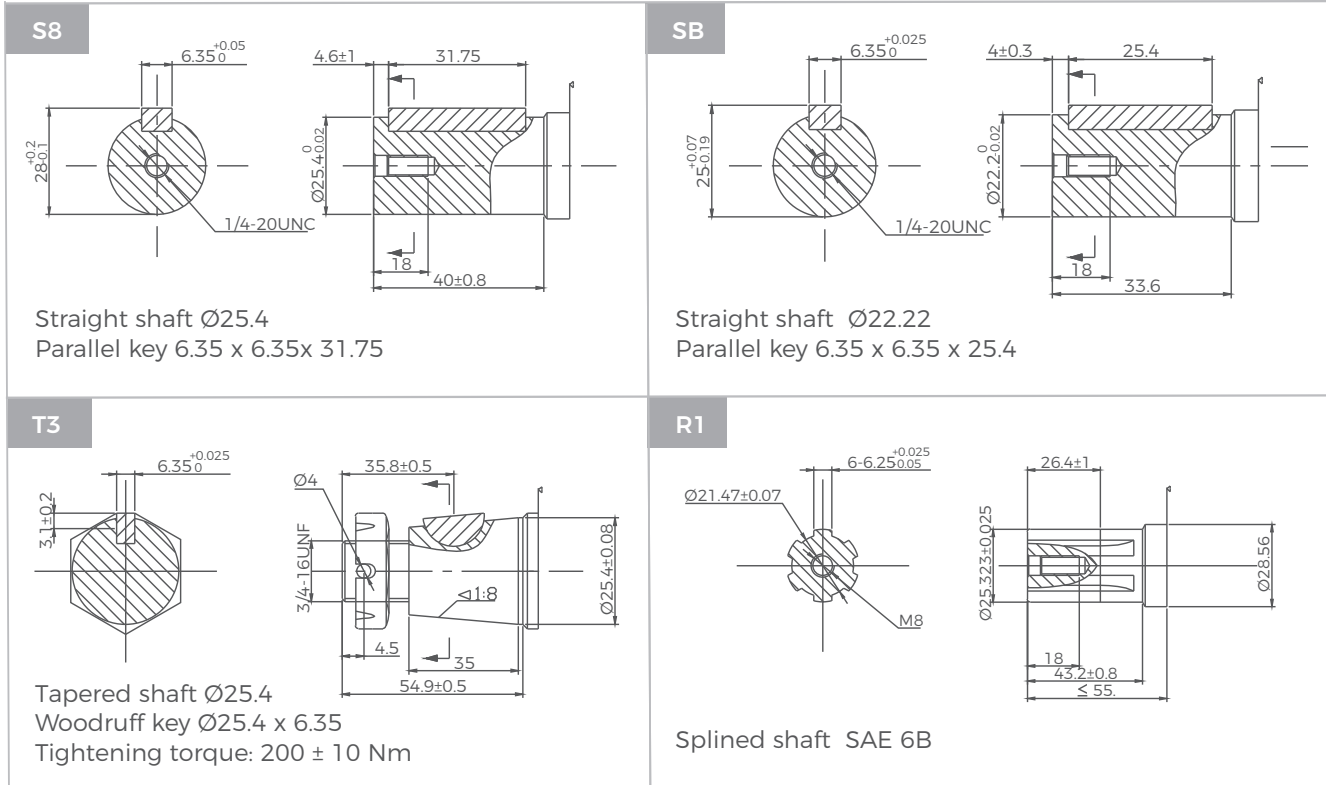

GFD Series Hydraulic Motors

Options

- Flange connection
- Motor with needle roller bearing
- Side and rear ports
- Shaft seal for high and low pressure
- Straight, splined and tapered shafts
- Metric and BSPP ports
- Other special features

Applications

- Scissor Lifts
- Snow Removal
- Augers
- Winches
- Sweepers
- Trenchers
- Skid Steer Attachments



General

Max.Displacement	cm ³ /rev [in ³ /rev]	959 [58.5]
Max.Speed	RPM	660
Max.Torque	Nm [lb-in]	cont.:1044 [9239] int.:1428 [12636]
Max.Output	kW [HP]	12.5 [16.8]
Max.Pressure Drop	bar [PSI]	cont.:207 [3000] int.:276 [4000]
Max.Oil Flow	lpm [GPM]	114 [30]
Pressure fluid		Mineral based- HLP (DIN 51524) or HM (ISO 6743/4)
Temperature Range	°C [°F]	-40–140 [-104–284]
Optimal Viscosity range	mm ² /s [SUS]	20–75 [98–347]
Filtration		ISO code 20/16 (Min.recommended fluid filtration of 25 microns)

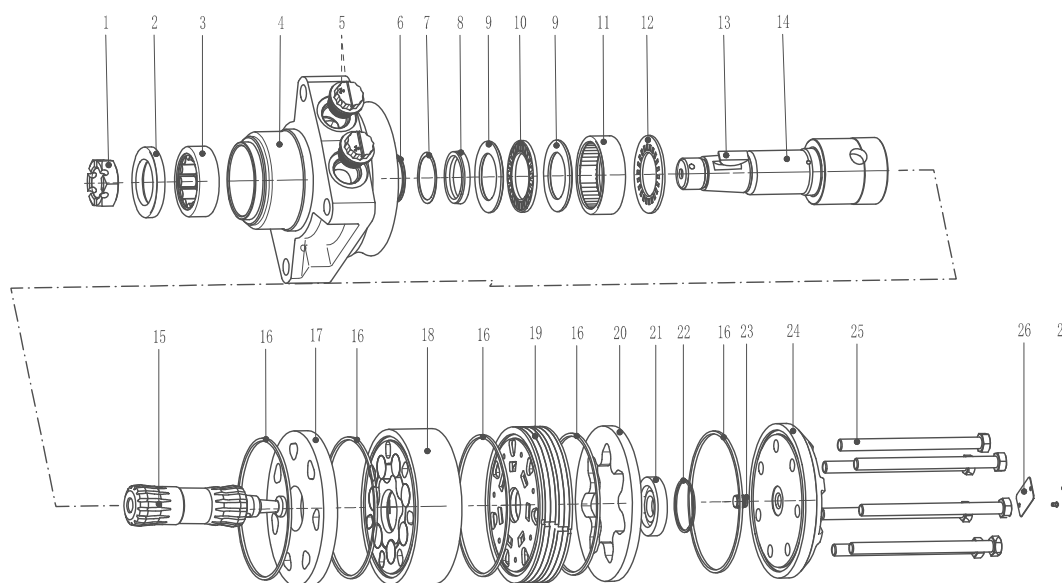

- | | | | | |
|---------------------------|---------------------------|--------------------------|---------------------|--------------|
| 1 Slotted nut | 7 Shaft seal gasket | 13 Woodruff key | 19 Welding plate | 25 Screw |
| 2 Dust ring | 8 Shaft seal | 14 Output shaft | 20 Spacer bush | 26 Nameplate |
| 3 Needle roller bearings | 9 Bearing retaining ring | 15 Transmission shaft | 21 Thrust plate | 27 Rivet |
| 4 Housing | 10 Flat bearing | 16 Rectangular seal ring | 22 Seal ring | |
| 5 Ports plug | 11 needle roller bearings | 17 Spacer | 23 Positioning pins | |
| 6 Shaft seal support ring | 12 Flat bearing | 18 Rotor and stator | 24 Rear cover | |

GFD Specifications

Type		GFD140	GFD170	GFD195	GFD240	GFD280
Displacement cm ³ /rev [in ³ /rev]		141[8.6]	169[10.3]	195[11.9]	238[14.5]	280[17.1]
Max.Speed RPM	Int.	660	554	477	393	334
Max.Oil Flow	Cont.	76[20]	76[20]	76[20]	76[20]	76[20]
Ipm [GPM]	Int.	95[25]	95[25]	95[25]	95[25]	95[25]
Max.Differential Pressure	Cont.	207[3000]	207[3000]	207[3000]	207[3000]	207[3000]
bar [PSI] Int.	Int.	276[4000]	276[4000]	276[4000]	276[4000]	276[4000]
Max.Supply Pressure bar [PSI]		300[4350]	300[4350]	300[4350]	300[4350]	300[4350]
Max.Torque	Cont.	390[3455]	476[4216]	556[4919]	677[5991]	796[7044]
daNm [lb-in]	Int.	530[4692]	646[5714]	753[6663]	913[8081]	1073[9499]
Max.Performance kW [HP]		33[45]	33[45]	33[45]	32[44]	31[42]
Min.Staring Torque	Cont.	315[2791]	376[3331]	451[3989]	582[5152]	675[5972]
daNm[lb-in]	Int.	418[3706]	505[4469]	611[5408]	776[6865]	870[7699]
Weight,kg [lb]	GFD	14.2[31.2]	14.5[31.9]	14.7[32.3]	15.1[33.2]	15.5[34.1]

Type		GFD310	GFD335	GFD405	GFD475	GFD530
Displacement cm ³ /rev [in ³ /rev]		310[18.9]	337[20.6]	405[24.7]	477[29.1]	528[32.3]
Max.Speed RPM	Int.	303	277	232	237	213
Max.Oil Flow	Cont.	76[20]	76[20]	76[20]	76[20]	76[20]
Ipm [GPM]	Int.	95[25]	95[25]	95[25]	114[30]	114[30]
Max.Differential Pressure	Cont.	207[3000]	207[3000]	2172[2500]	138[2000]	138[2000]
bar [PSI] Int.	Int.	276[4000]	276[4000]	241[3500]	207[3000]	172[2500]
Max.Supply Pressure bar [PSI]		300[4350]	300[4350]	300[4350]	300[4350]	300[4350]
Max.Torque	Cont.	924[8184]	964[8533]	942[8336]	887[7853]	983[8701]
daNm [lb-in]	Int.	1229[10817]	1297[11479]	1342[11877]	1372[12145]	1253[11086]
Max.Performance kW [HP]		31[41]	30[41]	27[37]	28[38]	23[31]
Min.Staring Torque	Cont.	778[6882]	843[7458]	791[7002]	740[6549]	874[7737]
daNm[lb-in]	Int.	1005[8893]	1117[9889]	1145[10133]	1120[9909]	1091[9657]
Weight,kg [lb]	GFD	15.7[34.5]	15.9[35.0]	16.5[36.3]	17.2[37.8]	17.9[39.4]



Specifications

Type		GFD625	GFD785	GFD960
Displacement cm ³ /rev [in ³ /rev]		623[38.0]	786[48.0]	859[58.5]
Max.Speed RPM	Int.	182	143	118
Max.Oil Flow	Cont.	76[20]	76[20]	76[20]
lpm [GPM]	Int.	114[30]	114[30]	114[30]
Max.Differential Pressure	Cont.	121[1750]	103[1500]	69[1000]
bar [PSI] Int.	Int.	155[2250]	138[2000]	103[1500]
Max.Supply Pressure bar [PSI]		300[4350]	300[4350]	300[4350]
Max.Torque	Cont.	986[8727]	1044[9239]	773[6843]
daNm [lb-in]	Int.	1291[11424]	1428[12636]	1268[11227]
Max.Performance kW [HP]		20[27]	17[23]	12[16]
Min.Staring Torque	Cont.	895[7924]	991[8772]	763[6752]
daNm[lb-in]	Int.	1165[10312]	1341[11876]	1177[10419]
Weight,kg [lb]	GFD	18.6[40.9]	20.2[44.4]	21.9[48.2]



Function Diagrams

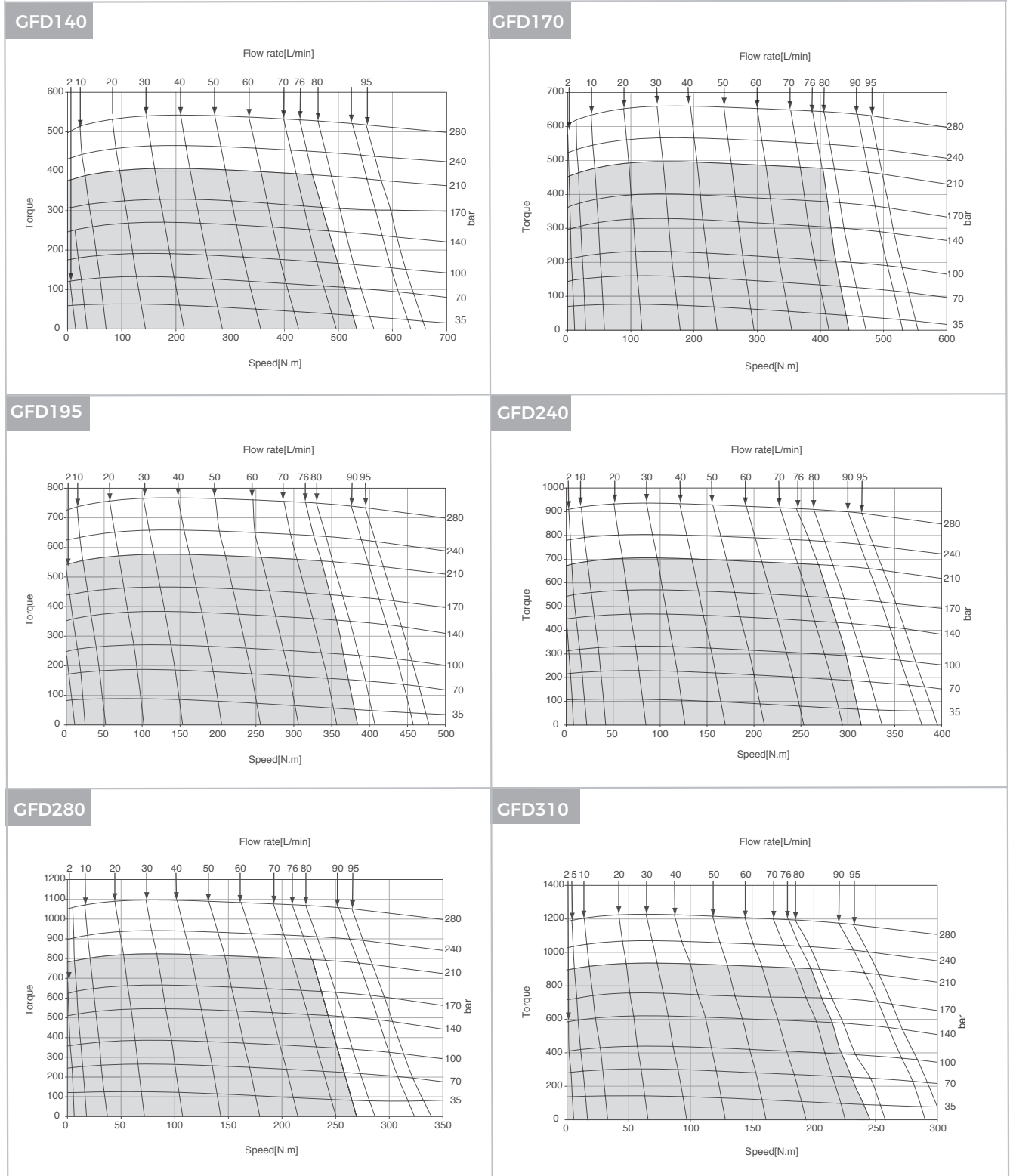

The function diagrams data is for average performance of randomly selected motors at backpressure. 5–10 bar [72.5–145 PSI] and oil with viscosity of 32mm²/s [150 SUS] at 50°C [122°F].

Function Diagrams

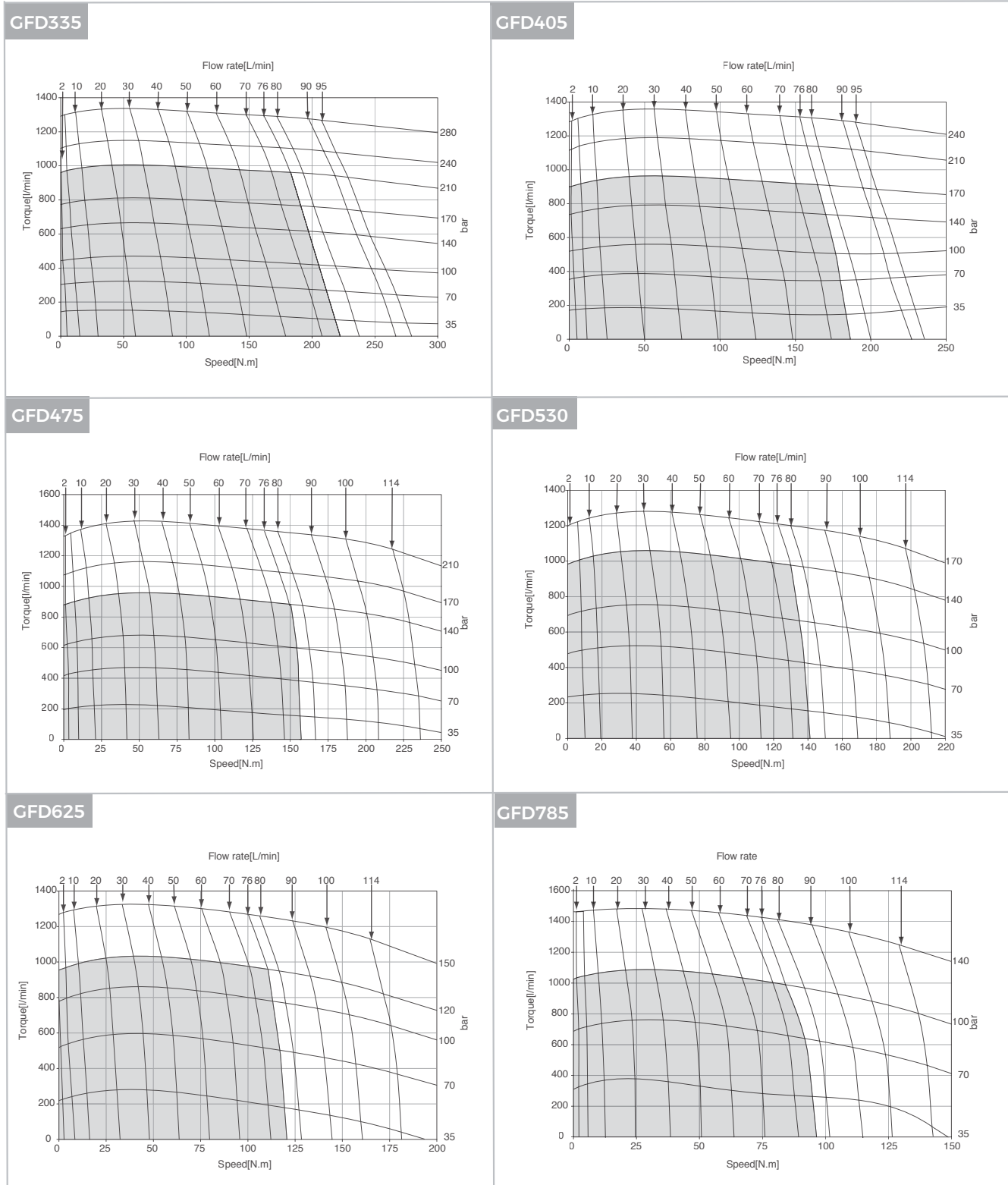

The function diagrams data is for average performance of randomly selected motors at backpressure. 5–10 bar [72.5–145 PSI] and oil with viscosity of 32mm²/s [150 SUS] at 50°C [122°F].

Function Diagrams

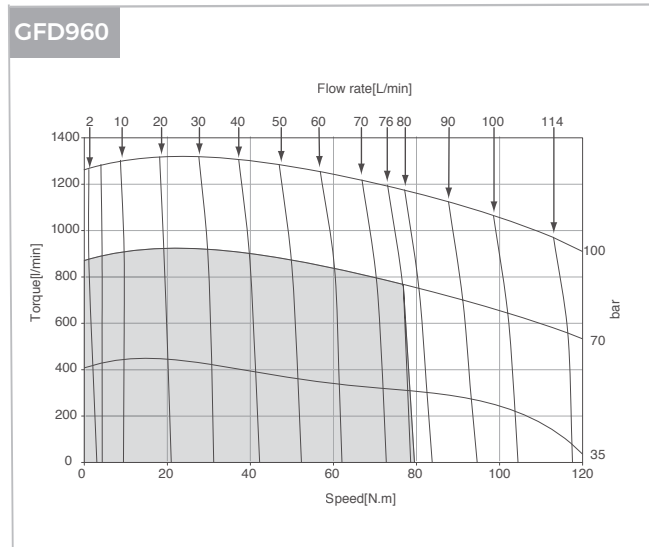

The function diagrams data is for average performance of randomly selected motors at backpressure. 5÷10 bar [72.5–145 PSI] and oil with viscosity of 32mm²/s [150 SUS] at 50°C [122°F].

GFD Flange Covers Dimensions

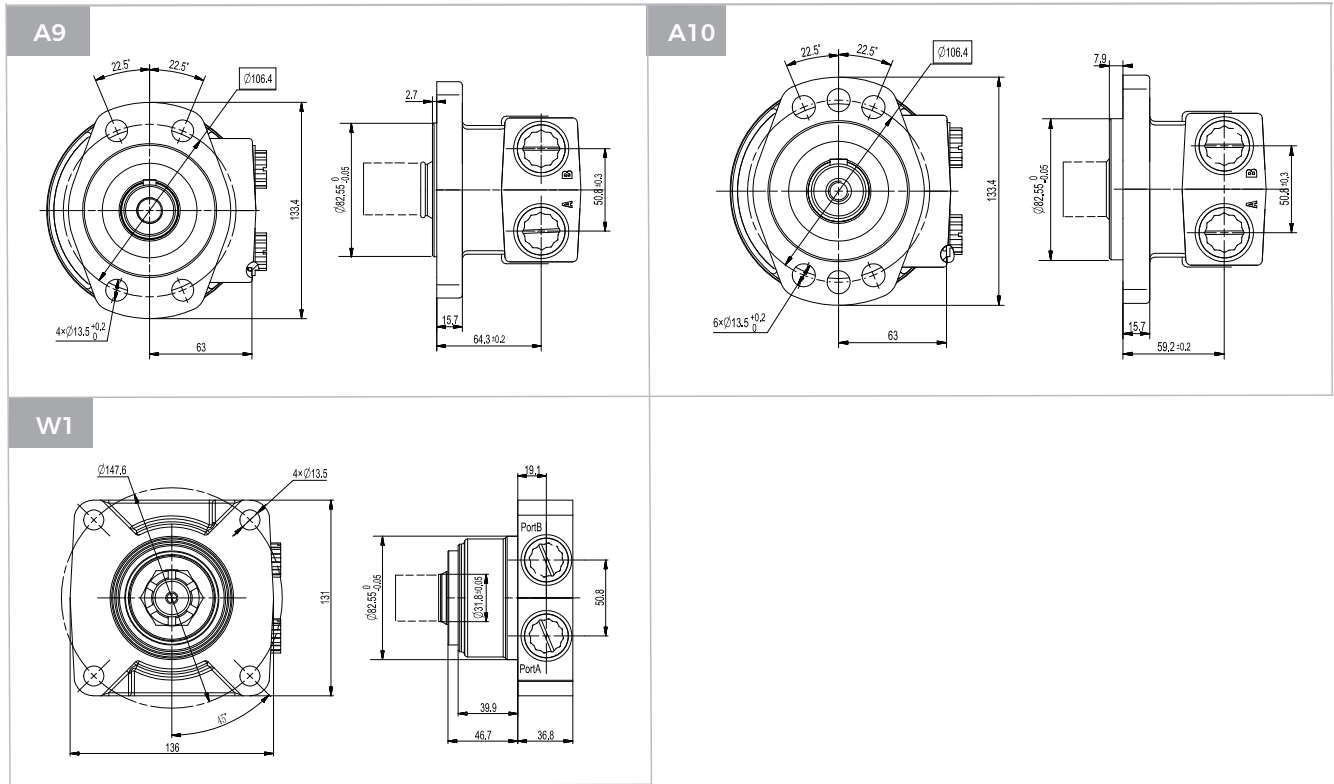

GFD Shafts Dimensions

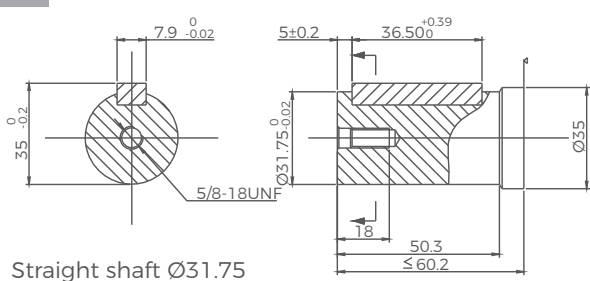
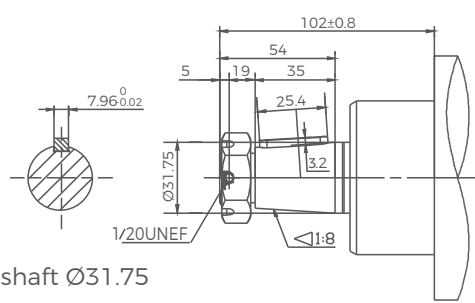
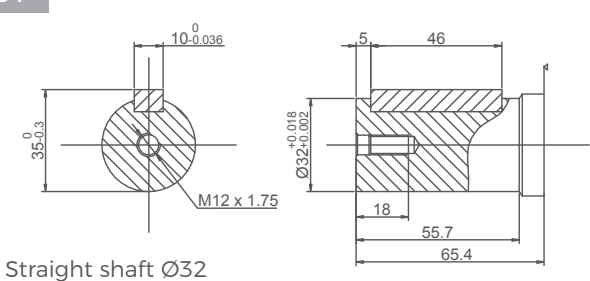
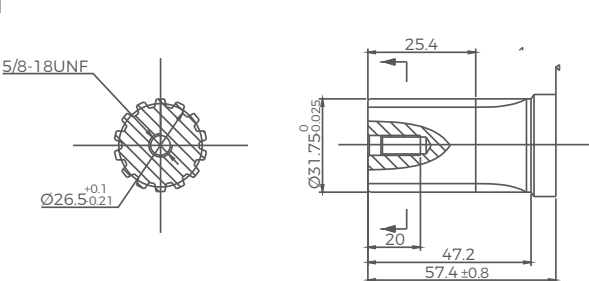
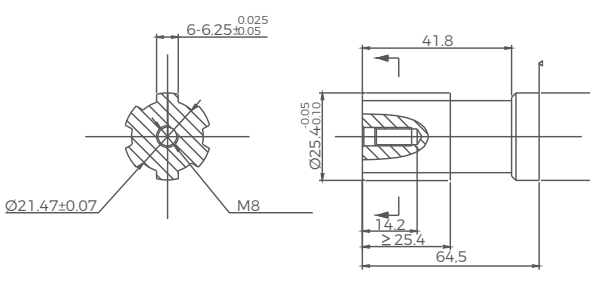
<p>SG</p>  <p>Straight shaft $\text{Ø}31.75$ Parallel key 7.9 x 7.9 x 36.5</p>	<p>TF</p>  <p>Tapered shaft $\text{Ø}31.75$ Parallel key 7.96 x 7.96 x 25.4</p>
<p>S4</p>  <p>Straight shaft $\text{Ø}32$ Parallel key 10 x 8 x 46</p>	<p>R6</p>  <p>Splined shaft 14-DP 12/24</p>
<p>R8</p>  <p>Splined shaft SAE 6B</p>	

GFE Series Hydraulic Motors

Options

- Flange connection
- Motor with needle roller bearing
- Shaft seal for high and low pressure
- Straight, splined and tapered shafts
- Metric and BSPP ports
- Other special features

Applications

- Snow Removal
- Salt and Sand Spreaders
- Oil and Gas Blender Trucks
- Scissor Lifts
- Augers
- Combine Header Drives
- Conveyers
- Combine Harvesters



General

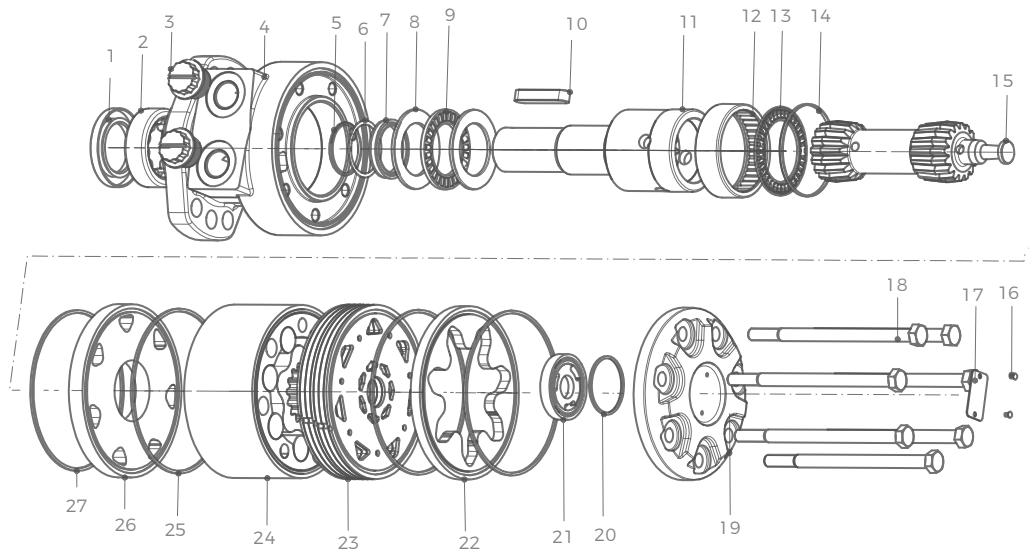

Max.Displacement	cm ³ /rev [in ³ /rev]	959[58.05]
Max.Speed	RPM	317
Max.Torque	daNm [lb-in]	cont.:1652[14624] int.:2028[17948]
Max.Output	kW [HP]	30[40]
Max.Pressure Drop	bar [PSI]	cont.:241[3500] int.:276[4000]
Max.Oil Flow	lpm [GPM]	114[30.0]
Pressure fluid		Mineral based-HLP (DIN 51524) or HM (ISO 6743/4)
Temperature Range	°C [°F]	-40-140[-40-284]
Optimal Viscosity range	mm ² /s [SUS]	20-75[98-347]
Filtration		ISO code 20/16 (Min.recommended fluid filtration of 25 microns)



- | | | | | |
|-------------------------|--------------------------------|--|------------------------------------|----------------------------|
| 1 Dust seal | 7 Shaft seal | 13 Plane thrust needle roller bearings | 17 Name plate | 22 Spacer sleeve |
| 2 Needle roller bearing | 8 Plane bearing retaining ring | 14 Outer ring of planar thrust needle roller bearing | 18 Hexagon bolts | 23 Welding plate assembly |
| 3 Plug | 9 Plane needle roller bearings | 15 transmission shaft | 19 Back cover | 24 Rotor stator assembly |
| 4 Housing | 10 Flat key | 16 Name plate rivet | 20 Distribution plate sealing ring | 25 Rectangular sealing NBR |
| 5 Shaft seal support | 11 Output shaft | | 21 Distribution plate | 26 Spacer |
| 6 Shaft seal gasket | 12 Roller bearings | | | 27 Rectangular sealing |

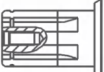
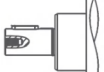

Ordering Code

GFE SERIES		DISP	FLANGE	SHAFT	PORTS	ROTATION	PAINT	FUNCTION					
CODE	DISP cm ³ /rev [in ³ /rev]	CODE	FLANGE	CODE	SHAFT	CODE	ROTATION	CODE	PAINT				
240	238 [14.5]	W1	Ø147.6 square 4- Ø13.5 front pilot Ø88.85X46.7 rear pilo Ø127X4 	R2	Ø31.75 splined tooth 14 M12x1.75 	A	Standard	S	Silver grey				
280	280 [17.1]			S4	Ø32 parallel key 10x8x46 					R	Opposite		
310	310 [18.9]			A10	6- Ø13.5 square Ø106.4 pilot Ø82.5x7.87 	CODE						PORTS	
335	337 [20.6]					G1	G1/2			A	No paint		
360	360 [22.2]					UF	7/8-14UNF					B	Blue
405	405 [24.7]					D5	Ø12.7 4X5/16-18UNC(13)						
475	477 [29.1]					CODE						FUNCTION	
530	528 [32.3]					A	Standard			N	Big radial force		
625	623 [38.0]					D	No case drain					F	Free running
785	786 [48.0]					L	Low speed						
960	959 [58.5]	S	Low temp.										

GFE Specifications

Type		GFE0240	GFE0280	GFE0310	GFE0335	GFE0360
Displacement cm ³ /rev [in ³ /rev]		238[14.5]	280[17.1]	310[18.9]	337[20.6]	360[22.2]
Max.Speed RPM	Int.	317	267	236	209	196
Max.Oil Flow	Cont.	76[20]	76[20]	76[20]	76[20]	76[20]
lpm [GPM]	Int.	95[25]	95[25]	95[25]	95[25]	95[25]
Max.Differential Pressure	Cont.	241[3500]	241[3500]	241[3500]	241[3500]	241[3500]
bar [PSI] Int.	Int.	276[4000]	276[4000]	276[4000]	276[4000]	276[4000]
Max.Supply Pressure bar [PSI]		300[4350]	300[4350]	300[4350]	300[4350]	300[4350]
Max.Torque	Cont.	794[7027]	936[8286]	1037[9175]	1128[9981]	1205[10665]
daNm [lb-in]	Int.	913[8031]	1073[9470]	1229[10465]	1297[11834]	1377[12189]
Max.Performance kW [HP]		30[40]	29[39]	29[39]	28[37]	28[37]
Min.Staring Torque	Cont.	593[5250]	699[6190]	773[6841]	843[7457]	900[7968]
daNm[lb-in]	Int.	678[6000]	799[7075]	883[7819]	963[8522]	1029[9107]
Weight.kg [lb]	GFE	14.8[327]	15.2[33.5]	15.4[33.9]	15.5[34.2]	15.8[34.8]

Type		GFE310	GFE0475	GFE0530	GFE0625	GFE0785	GFE0960
Displacement cm ³ /rev [in ³ /rev]		405[24.7]	477[29.1]	528[32.3]	623[38.0]	786[48.0]	959[58.5]
Max.Speed RPM	Int.	184	204	173	151	120	102
Max.Oil Flow	Cont.	76[20]	76[20]	76[20]	76[20]	76[20]	76[20]
lpm [GPM]	Int.	95[25]	114[30]	114[30]	114[30]	114[30]	114[30]
Max.Differential Pressure	Cont.	241[3500]	241[3500]	224[3250]	190[2750]	152[2200]	124[1800]
bar [PSI] Int.	Int.	276[4000]	276[4000]	259[3750]	224[3250]	186[2700]	159[2300]
Max.Supply Pressure bar [PSI]		300[4350]	300[4350]	300[4350]	300[4350]	300[4350]	300[4350]
Max.Torque	Cont.	1353[11971]	1593[14101]	1643[14537]	1635[14469]	1652[14624]	1647[14580]
daNm [lb-in]	Int.	1546[13681]	1821[16115]	1895[16774]	1932[17100]	2028[17948]	2105[18630]
Max.Performance kW [HP]		29[39]	37[49]	32[43]	28[38]	22[30]	19[26]
Min.Staring Torque	Cont.	1011[8944]	1190[10535]	1227[10861]	1221[10810]	1234[10926]	1231[10893]
daNm[lb-in]	Int.	1155[10222]	1360[12040]	1416[12532]	1443[12776]	1515[13409]	1504[13314]
Weight.kg [lb]	GFE	16.1[35.4]	16.6[36.7]	17.3[38.1]	18.0[39.6]	19.8[43.6]	20.8[45.9]

GFE Dimensions and Mountings

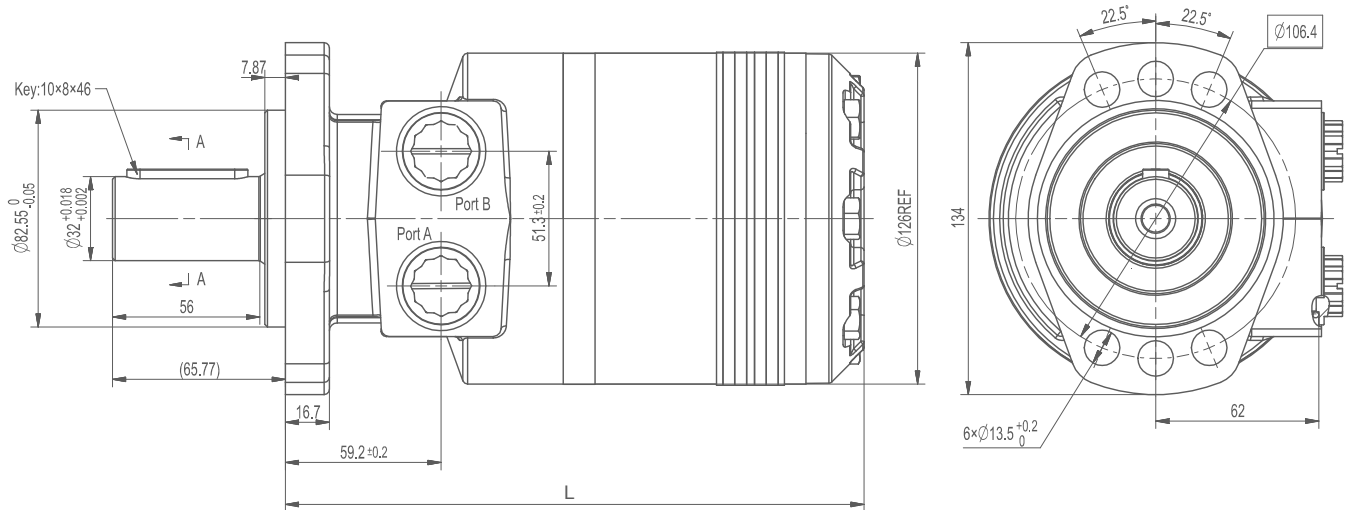

Model	L1(mm)
GFE 240	202.4
GFE 280	206.8
GFE 310	209.8
GFE 335	212.3
GFE 360	215.6
GFE 405	218.7
GFE 475	225.8
GFE 530	230.9
GFE 625	239.8
GFE 785	256.0
GFE 960	272.5

Mounting	G1 (depth)	UF (depth)	D5 (depth)
P(A, B)	G1/2	7/8-14 UNF	12.7
C			4x5/16-18UNC(13)



GFE Flange Covers Dimensions

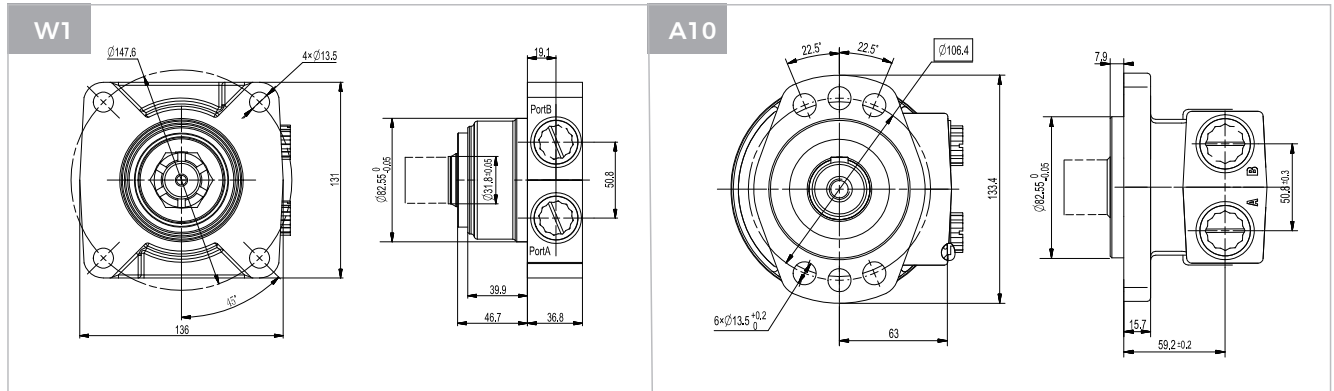



GFE Shafts Dimensions

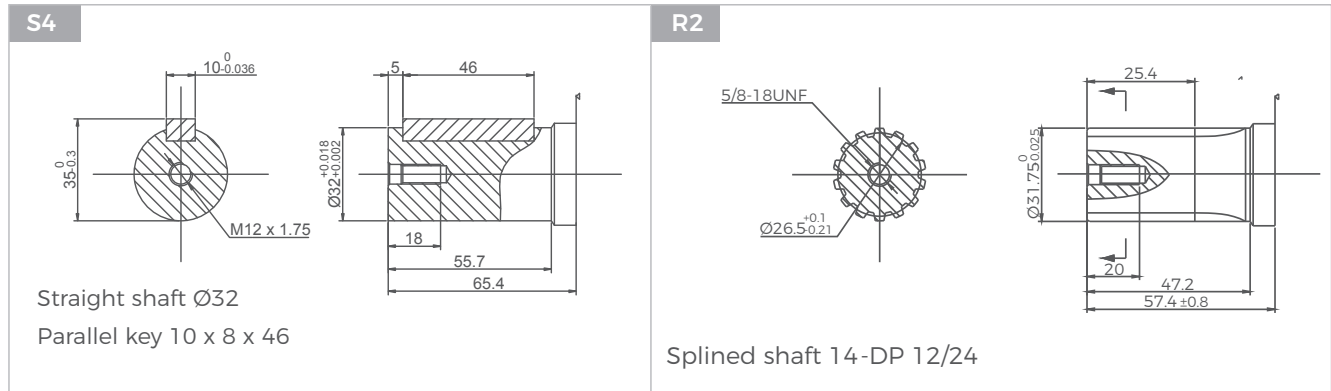

GFF Series Hydraulic Motors

Options

- Flange connection
- Motor with needle roller bearing
- Side and rear ports
- Shaft seal for high and low pressure
- Straight, splined and tapered shafts
- Metric and BSPP ports
- Other special features

Applications

- Trenchers
- Skid Steer Attachments
- Scissor Lifts
- Sweepers
- Wood Chippers
- Conveyers
- Combine Harvesters



General

Max.Displacement	cm ³ /rev [in ³ /rev]	477[29.1]
Max.Speed	RPM	693
Max.Torque	daNm [lb-in]	cont.:68.1[6027] int.:85.1[7528]
Max.Output	kW [HP]	17.4[23.3]
Max.Pressure Drop	bar [PSI]	cont.:207[3000] int.:276[4000]
Max.Oil Flow	lpm [GPM]	100[37.85]
Pressure fluid		Mineral based-HLP (DIN 51524) or HM (ISO 6743/4)
Temperature Range	°C [°F]	-40–140[-104–284]
Optimal Viscosity range	mm ² /s [SUS]	20–75[98–347]
Filtration		ISO code 20/16 (Min.recommended fluid filtration of 25 microns)

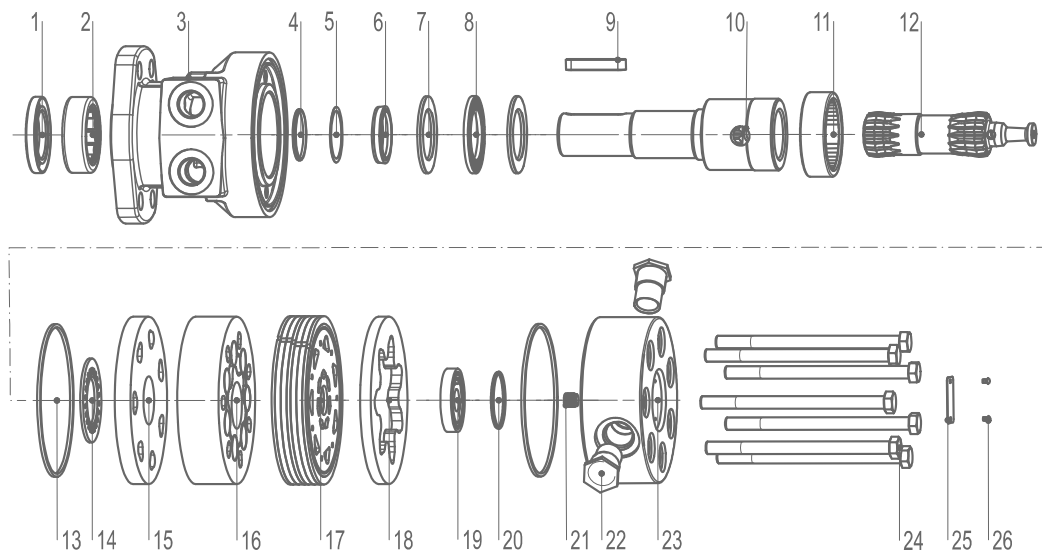

- | | | | | |
|-------------------------|--------------------------------|--|-----------------------------|-------------------------------|
| 1 Dust seal | 7 Plane bearing retaining ring | 13 Rectangular sealing ring | 18 Spacer | 24 Hexagon bolts |
| 2 Needle roller bearing | 8 Plane needle roller bearings | 14 Plane thrust needle roller bearings | 19 Distribution plate | 25 Rear cover positioning pin |
| 3 Housing | 9 Flat key | 15 Spacer | 20 Port plate sealing ring | 26 Sign rivets |
| 4 Shaft seal support | 10 Output shaft | 16 Rotor stator assembly | 21 Signage | |
| 5 Shaft seal gasket | 11 Roller bearings | 17 Welding plate assembly | 22 Rectangular sealing ring | |
| 6 Shaft sealing | 12 transmission shaft | | 23 Back cover | |

Ordering Code

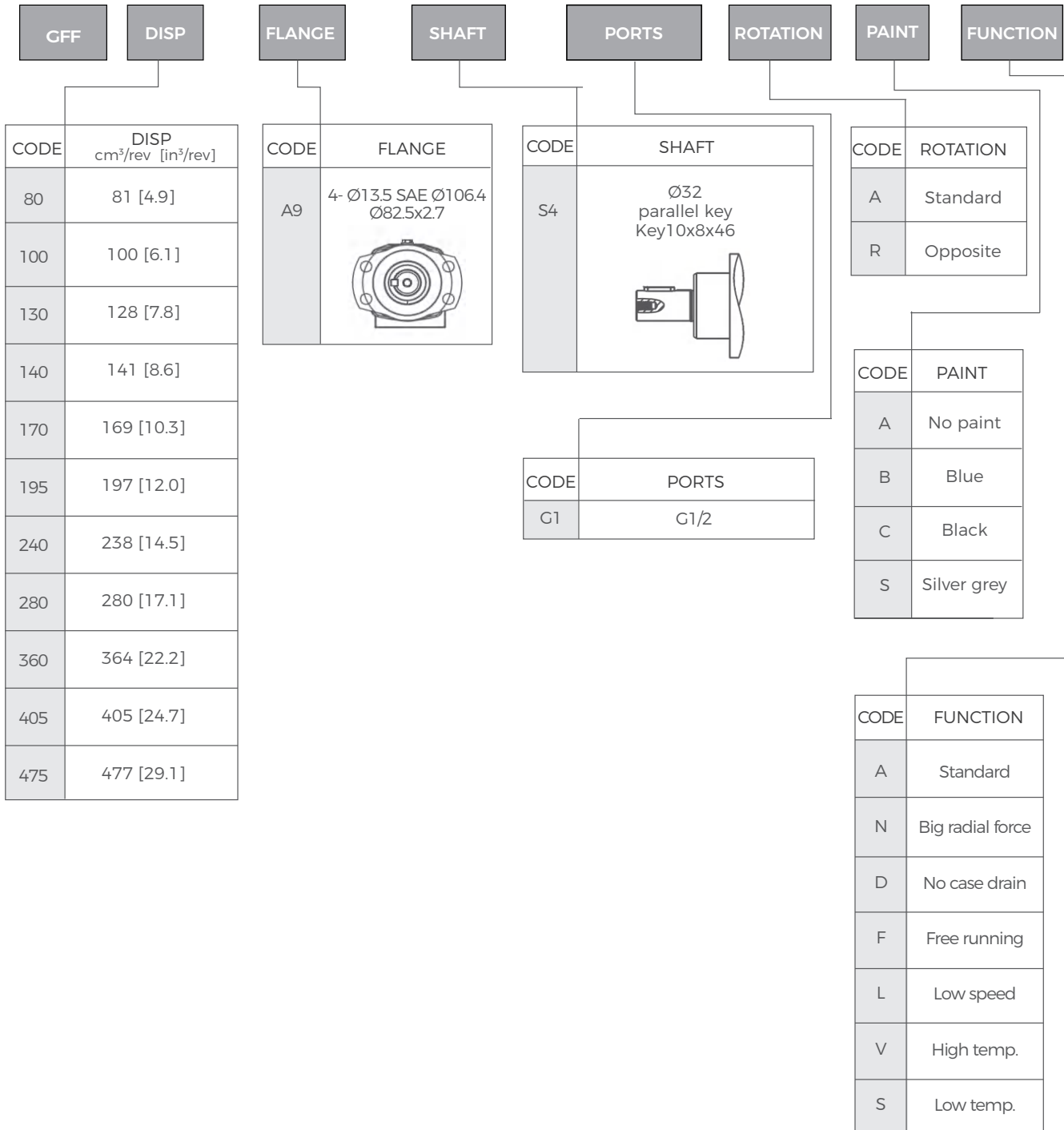

GFF Specifications

Type		GFF80	GFF100	GFF130	GFF140	GFF170	GFF195
Displacement cm ³ /rev [in ³ /rev]		81[4.9]	128[7.8]	128[7.8]	141[8.6]	169[10.3]	197[12.0]
Max.Speed RPM	Int.	693	583	583	530	444	381
Max.Oil Flow	Cont.	46[12]	57[15]	57[15]	57[15]	57[15]	57[15]
lpm [GPM]	Int.	57[15]	76[20]	76[20]	76[20]	76[20]	76[20]
Max.Differential Pressure	Cont.	207[3000]	138[2000]	138[2000]	138[2000]	138[2000]	138[2000]
bar [PSI] Int.	Int.	276[4000]	207[3000]	207[3000]	207[3000]	207[3000]	207[3000]
Max.Supply Pressure bar [PSI]		300[4350]	300[4350]	300[4350]	300[4350]	300[4350]	300[4350]
Max.Torque	Cont.	22.0[1948]	22.9[2031]	22.9[2031]	25.4[2248]	31.7[2808]	36.4[3222]
daNm [lb-in]	Int.	29.6[2621]	35.6[3148]	35.6[3148]	39.3[3477]	48.9[4324]	56.2[4971]
Max.Performance kW [HP]		21.5[28.8]	21.7[29.1]	21.7[29.1]	21.8[29.2]	22.7[30.5]	22.4[30.1]
Min.Staring Torque	Cont.	15.8[1401]	18.0[1596]	18.0[1596]	19.6[1739]	24.3[2152]	30.2[2671]
daNm[lb-in]	Int.	20.5[1811]	27.8[2460]	27.8[2460]	30.8[2728]	38.5[3404]	46.8[4142]
Weight.kg [lb]	GFF	13.6[29.9]	13.8[30.4]	13.8[30.4]	13.9[30.6]	14.2[31.2]	14.5[31.9]

Type		GFF240	GFF280	GFF360	GFF365	GFF405	GFF475
Displacement cm ³ /rev [in ³ /rev]		238[14.5]	280[17.1]	364[22.2]	364[22.2]	405[24.7]	477[29.1]
Max.Speed RPM	Int.	394	334	258	258	231	195
Max.Oil Flow	Cont.	76[20]	76[20]	76[20]	76[20]	76[20]	76[20]
lpm [GPM]	Int.	95[20]	95[25]	95[25]	95[25]	95[25]	95[25]
Max.Differential Pressure	Cont.	138[2000]	138[2000]	130[1880]	97[1400]	128[1850]	113[1645]
bar [PSI] Int.	Int.	207[3000]	207[3000]	190[2750]	152[2200]	172[2750]	138[2000]
Max.Supply Pressure bar [PSI]		300[4350]	300[4350]	300[4350]	300[4350]	300[4350]	300[4350]
Max.Torque	Cont.	42.7[3782]	50.9[4502]	59.4[5257]	43.7[3871]	65.5[5800]	68.1[6027]
daNm [lb-in]	Int.	67.0[5928]	79.4[7029]	88.0[7788]	74.0[6456]	91.6[8106]	85.1[7528]
Max.Performance kW [HP]		27.7[37.1]	27.8[37.3]	20.0[26.8]	20.0[26.8]	22.1[29.7]	17.4[23.3]
Min.Staring Torque	Cont.	36.6[3242]	43.8[3876]	51.7[4575]	39.8[3521]	57.5[5091]	60.3[5334]
daNm[lb-in]	Int.	57.2[5058]	67.2[5946]	77.9[6898]	65.0[5749]	78.9[6978]	74.0[6548]
Weight.kg [lb]	GFF	14.9[32.8]	15.2[33.4]	16.0[35.2]	16.0[35.2]	16.5[35.6]	17.2[37.8]

Function Diagrams

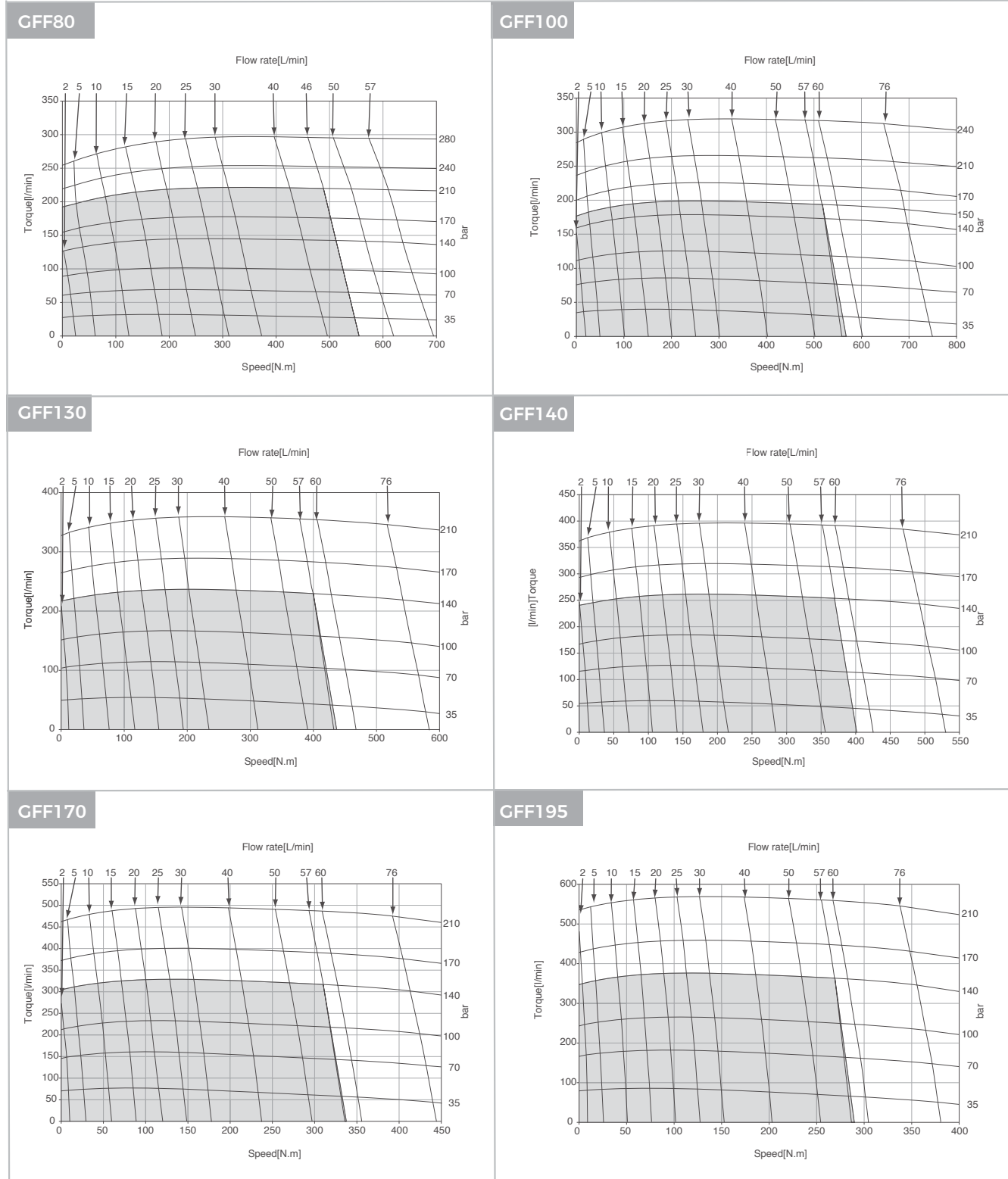

The function diagrams data is for average performance of randomly selected motors at backpressure. 5–10 bar [72.5–145 PSI] and oil with viscosity of 32mm²/s [150 SUS] at 50°C [122°F].

Function Diagrams

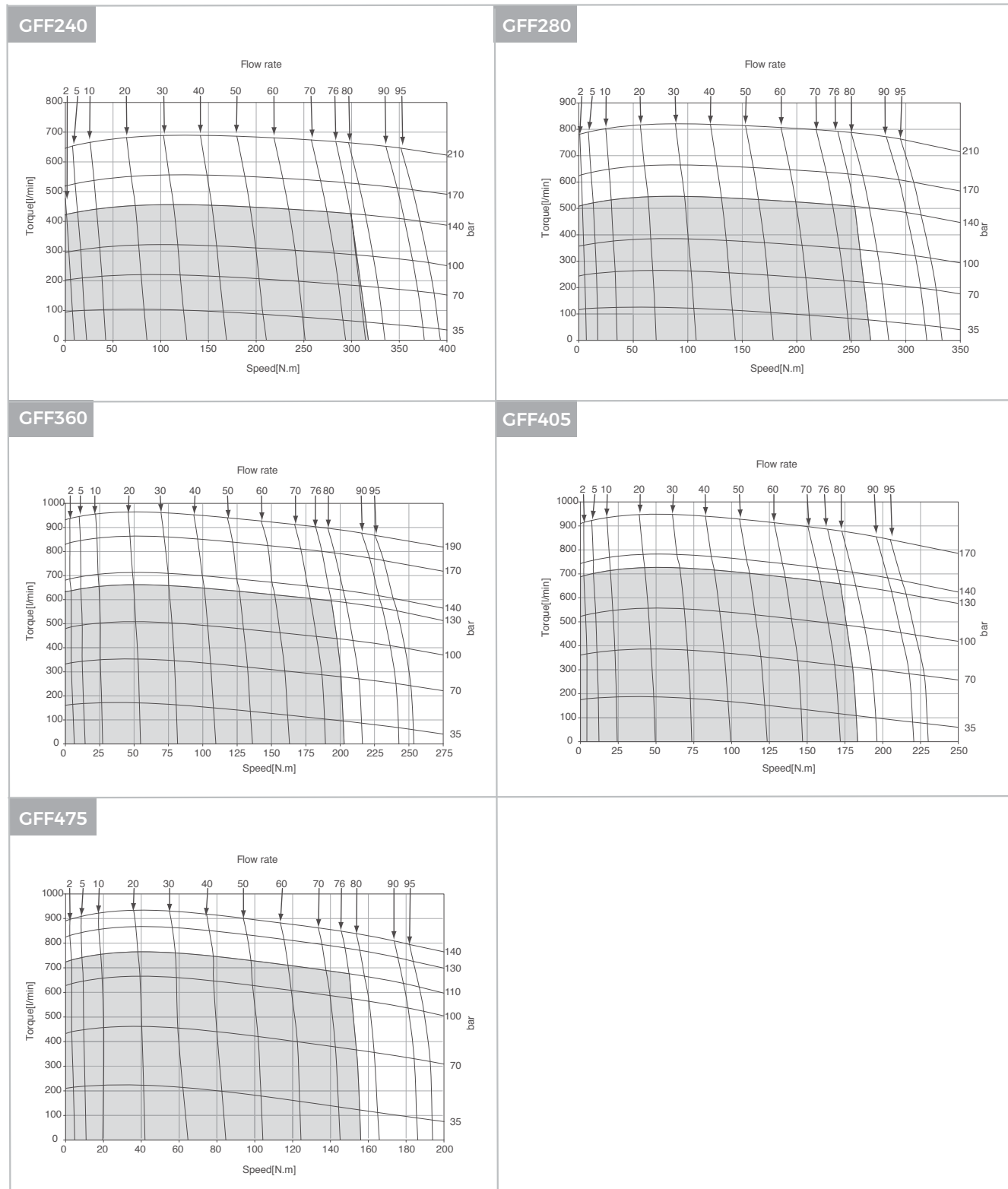

The function diagrams data is for average performance of randomly selected motors at backpressure. 5–10 bar [72.5–145 PSI] and oil with viscosity of 32mm²/s [150 SUS] at 50°C [122°F].

GFF Dimensions and Mountings

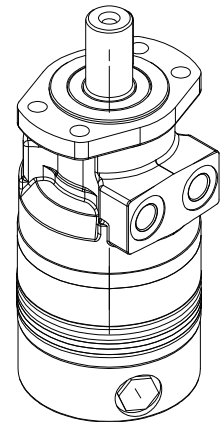
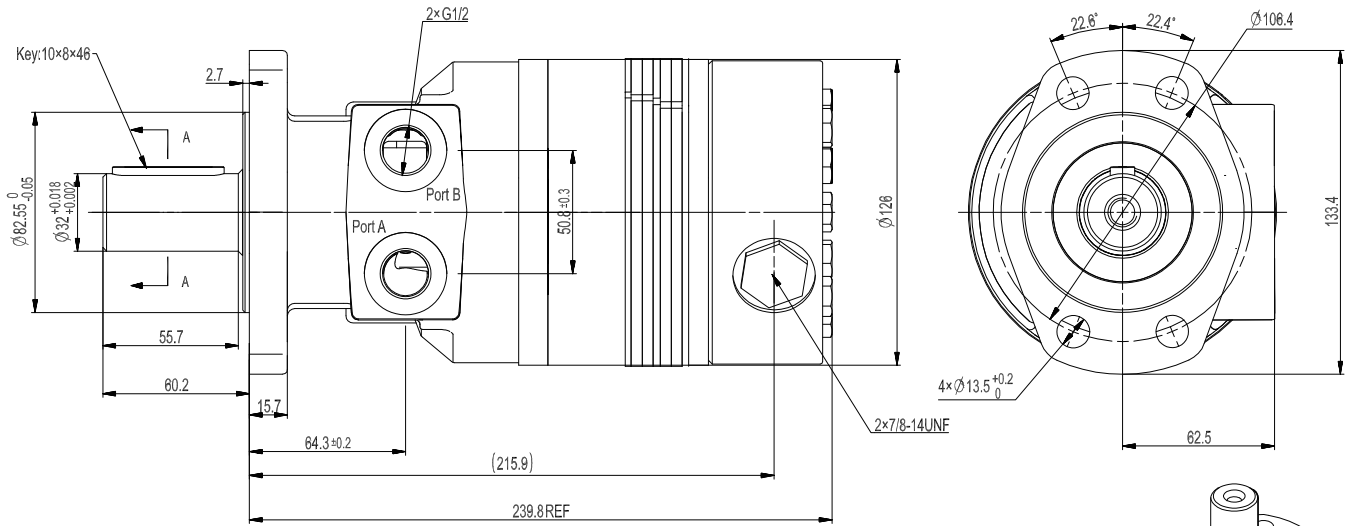

Model	L(mm)
GFF80	191
GFF100	191
GFF130	194
GFF140	196
GFF170	199
GFF195	202
GFF240	207
GFF280	211
GFF360	221
GFF405	225
GFF475	234

Mounting	G1 (depth)
P(A, B)	G1/2

GFF Flange Covers Dimensions

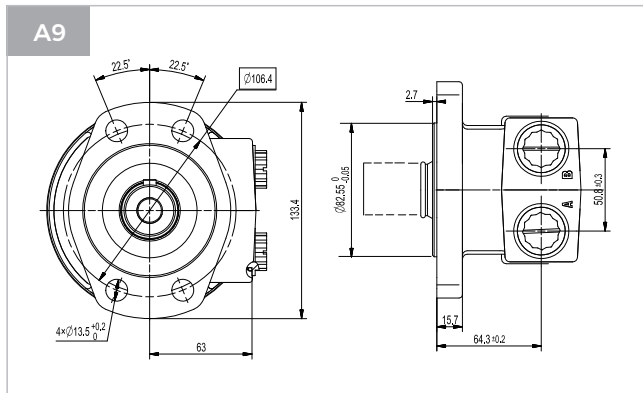

GFF Shafts Dimensions

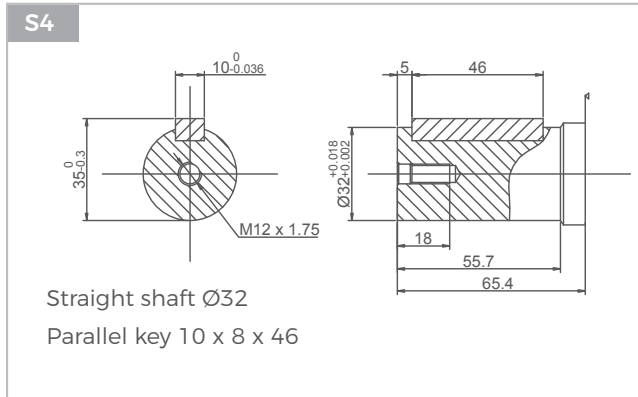

GFK Series Hydraulic Motors

Options

- Flange connection
- Motor with needle roller bearing
- Side and rear ports
- Shaft seal for high and low pressure
- Straight, splined and tapered shafts
- Metric and BSPP ports
- Other special features

Applications

- Sweepers
- Snow Removal
- Combine Harvesters
- Winches
- Sprayers
- Skid Steer Attachments
- Conveyers

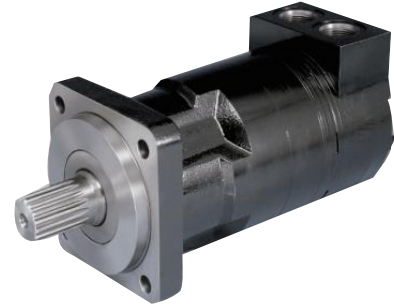

General

Max.Displacement	cm ³ /rev [in ³ /rev]	1000[61.0]
Max.Speed	RPM	523
Max.Torque	daNm [lb-in]	cont.:241.3[21360] int.:266[23540]
Max.Output	kW [HP]	48.7[65.3]
Max.Pressure Drop	bar [PSI]	cont.:241[3500] int.:310[4500]
Max.Oil Flow	lpm [GPM]	227[60.0]
Pressure fluid		Mineral based- HLP (DIN 51524) or HM (ISO 6743/4)
Temperature Range	°C [°F]	-40-140[-104-284]
Optimal Viscosity range	mm ² /s [SUS]	20-75[98-347]
Filtration		ISO code 20/16 (Min.recommended fluid filtration of 25 microns)

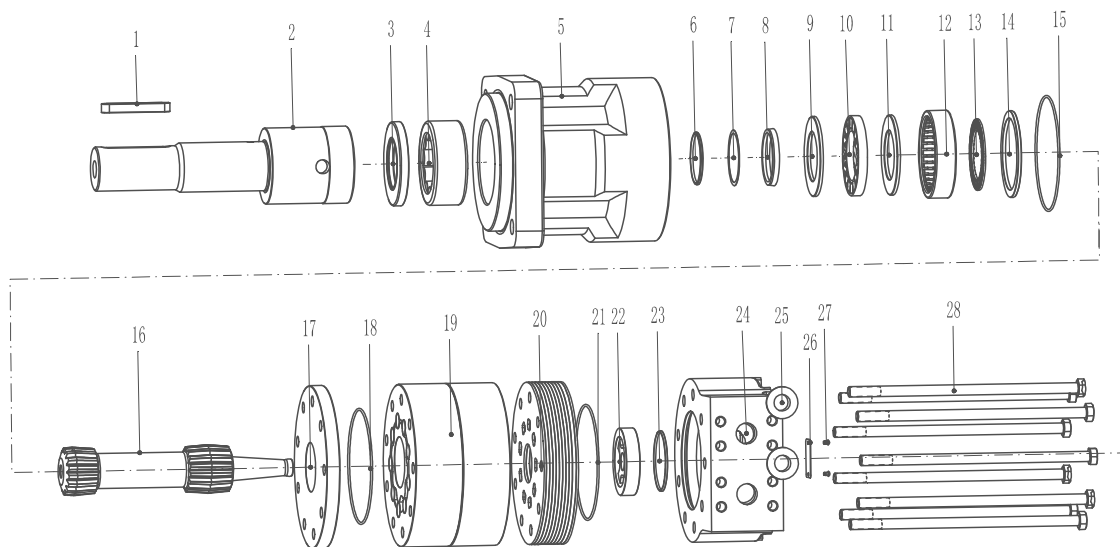

- | | | | | |
|-------------------------|--------------------------------|--|------------------------------------|----------------------------|
| 1 Flat key | 7 Shaft seal | 13 Outer ring of planar thrust needle roller 14bearing | 18 Back cover | 23 Sealing ring |
| 2 Needle roller bearing | 8 Plane bearing retaining ring | 14 transmission shaft | 19 Distribution plate sealing ring | 24 Rectangular sealing NBR |
| 3 Plug | 9 Plane needle roller bearings | 15 Name plate rivet | 20 Distribution plate | 25 Spacer |
| 4 Housing | 10 Flat key | 16 Name plate | 21 Spacer sleeve | 26 Rectangular sealing |
| 5 Shaft seal support | 11 Output shaft | 17 Spacer disk | 22 Welding plate assembly | |
| 6 Shaft seal gasket | 12 Roller bearings | | | |



Ordering Code

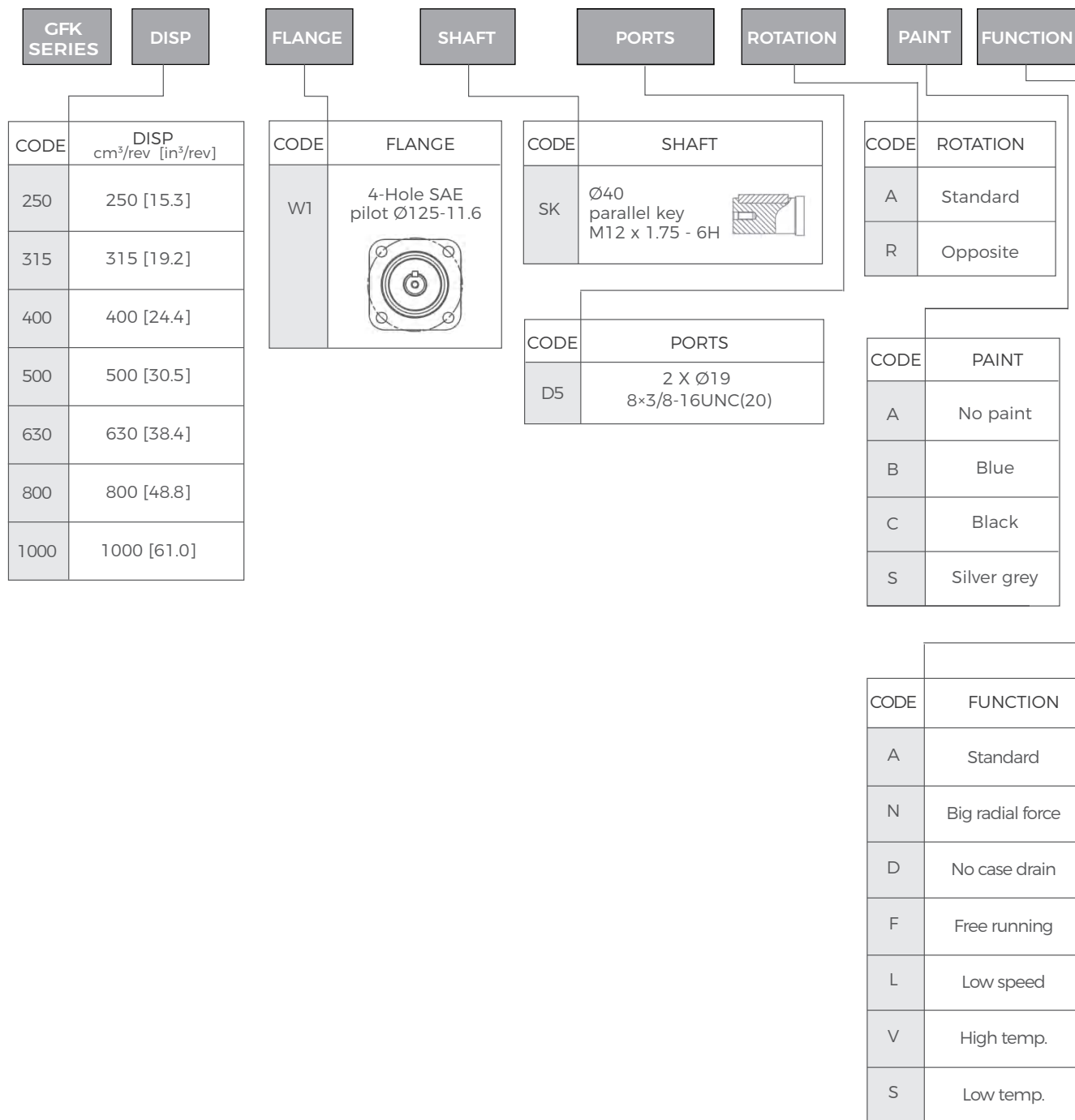

GFK Specifications

Type		GFK250	GFK315	GFK400	GFK500
Displacement cm ³ /rev [in ³ /rev]		250[15.3]	315[19.2]	400[24.4]	500[30.5]
Max.Speed RPM	Int.	523	413	373	298
Max.Oil Flow	Cont.	114[30]	114[30]	114[30]	114[30]
lpm [GPM]	Int.	133[35]	133[35]	151[40]	151[40]
Max.Differential Pressure	Cont.	241[3500]	241[3500]	207[3000]	207[3000]
bar [PSI] Int.	Int.	310[4500]	310[4500]	276[4000]	276[4000]
Max.Supply Pressure bar [PSI]		328[4750]	328[4750]	328[4750]	328[4750]
Max.Torque	Cont.	81.4[7204]	102.9[9105]	115.3[10201]	143.9[12736]
daNm [lb-in]	Int.	104.3[9234]	131.4[11625]	152.4[13484]	191.4[16940]
Max.Performance kW [HP]		48.5[65.0]	47.4[63.5]	48.7[65.3]	48.1[64.5]
Min.Staring Torque	Cont.	68.9[6100]	94.9[8400]	104.9[9280]	132.2[11700]
daNm[lb-in]	Int.	87.9[7780]	121.7[10770]	141[12480]	178.3[15780]
Weight,kg [lb]	GFK	32.0[70.6]	32.7[72.0]	33.5[73.8]	34.5[76.0]

Type		GFK630	GFK800	GFK1000
Displacement cm ³ /rev [in ³ /rev]		630[38.4]	800[48.8]	1000[61.0]
Max.Speed RPM	Int.	237	276	218
Max.Oil Flow	Cont.	114[30]	151[40]	151[40]
lpm [GPM]	Int.	151[40]	227[60]	227[60]
Max.Differential Pressure	Cont.	207[3000]	190[2750]	172[2500]
bar [PSI] Int.	Int.	224[3250]	207[3000]	190[2750]
Max.Supply Pressure bar [PSI]		328[4750]	328[4750]	328[4750]
Max.Torque	Cont.	161.7[14313]	191.6[16960]	241.3[21360]
daNm [lb-in]	Int.	171.6[15187]	230[20360]	266[23540]
Max.Performance kW [HP]		33.7[45.2]	44.4[59.5]	35.4[47.5]
Min.Staring Torque	Cont.	149.7[13250]	174.5[15440]	198.1[17535]
daNm[lb-in]	Int.	162.1[14350]	190.2[16834]	218[19290]
Weight,kg [lb]	GFK	35.7[78.8]	37.2[82.1]	39.1[86.3]

Function Diagrams

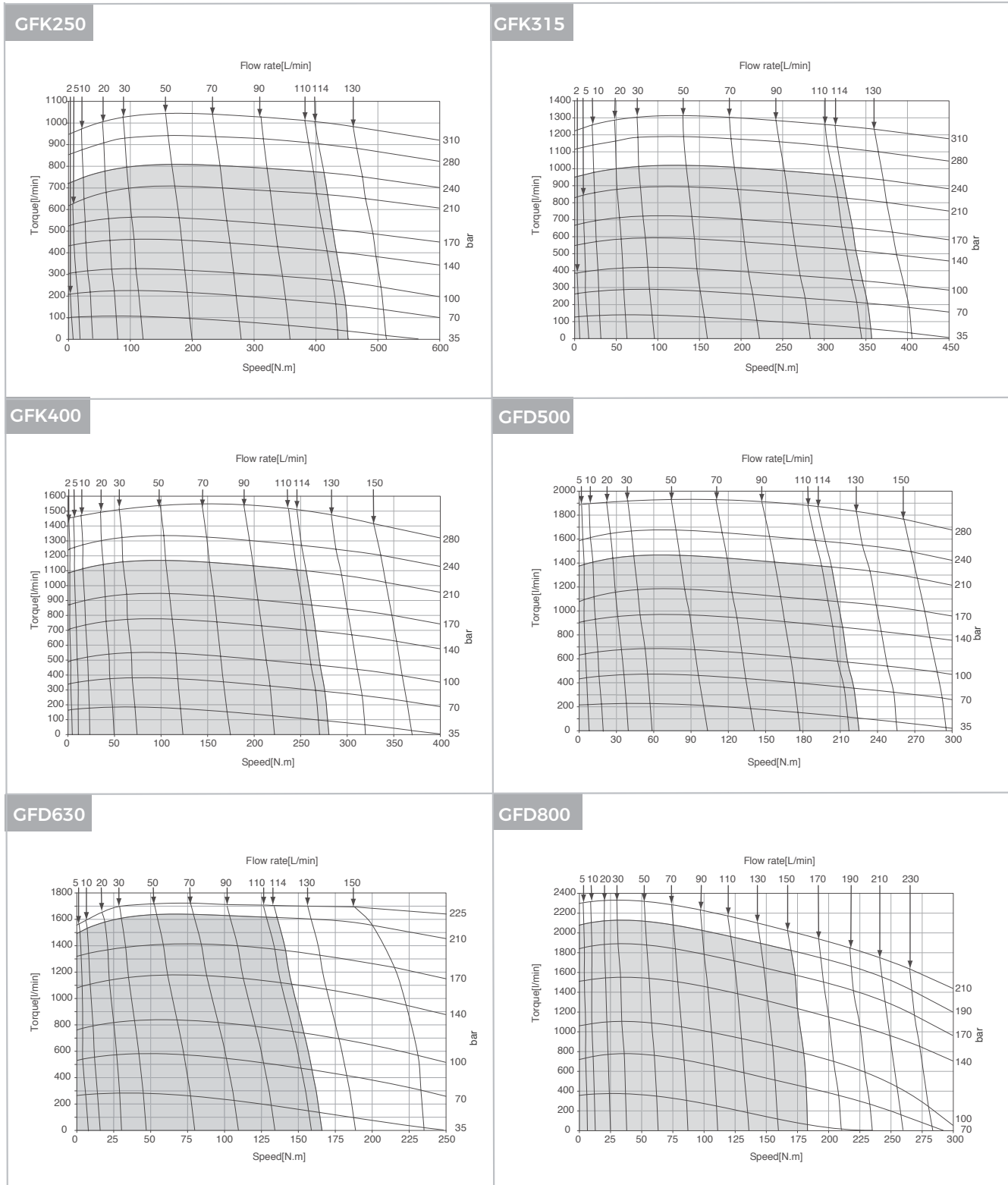

The function diagrams data is for average performance of randomly selected motors at backpressure. 5–10 bar [72.5–145 PSI] and oil with viscosity of 32 mm²/s [150 SUS] at 50°C [122°F].



Function Diagrams

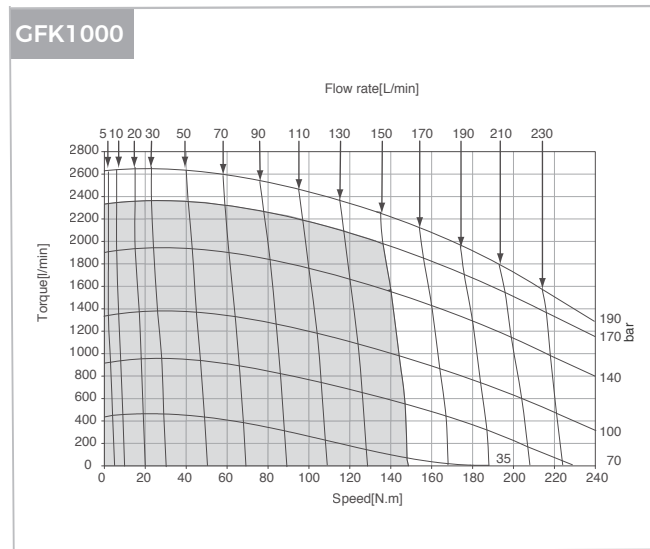

The function diagrams data is for average performance of randomly selected motors at backpressure. 5–10 bar [72.5–145 PSI] and oil with viscosity of 32 mm²/s [150 SUS] at 50°C [122°F].



GFK Flange Covers Dimensions

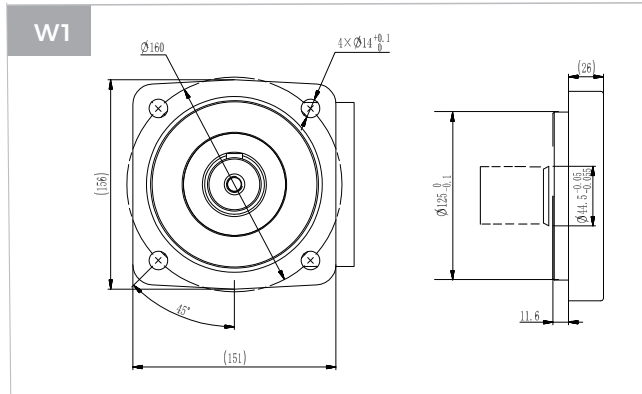

GFK Shafts Dimensions

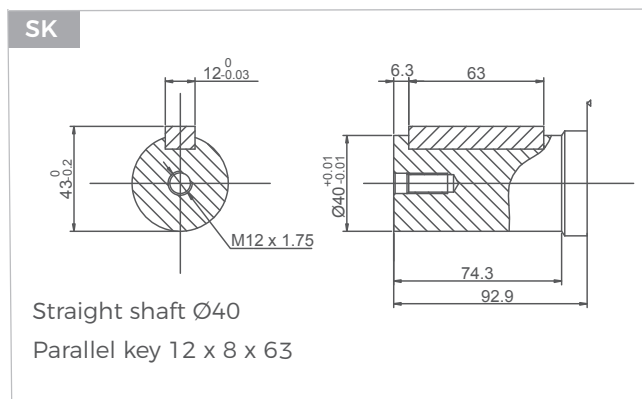

GGM Series Hydraulic Motors

Options

- Gerotor design
- Side ports, rear ports
- Straight, splined shafts
- SAE ports
- Roller bearings for long life
- High pressure mechanical seals

Applications

- Construction machines
- Refuse/dump truck
- Material handling
- Forestry machines
- Agriculture machines
- Industrial machines



General

Max. Displacement	cm ³ /rev [in ³ /rev]	11.47 [.700]
Max. Speed	RPM	5000
Max. Torque 1000 PSI	in.-lbs [kg-cm]	111 [128]
Max. Output	kW [HP]	64 [85.8]
Max. Pressure Drop	bar [PSI]	cont.: 138 [2000] int.: 172.58 [2500]
Max. Oil Flow	lpm [GPM]	56.7[15]
Max. Shaft Side Loads	lbs. [kg]	170 [77]
Pressure fluid		Mineral based-HLP (DIN 51524) or HM (ISO 6743/4)
Temperature Range	°C [°F]	-40–140[-104–284]
Optimal Viscosity range	mm ² /s [SUS]	20–75[98–347]
Filtration		ISO code 20/16 (Min. recommended fluid filtration of 25 microns)

When used in series, the back pressure shall not exceed 69bar.

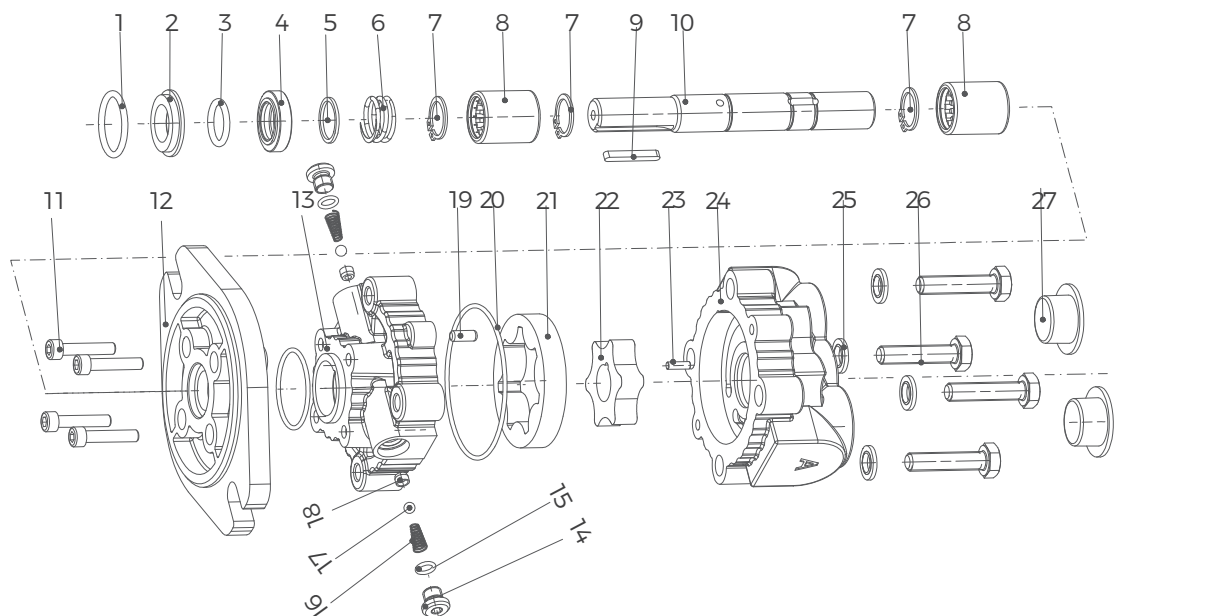

- | | | | | |
|---------------------------|-------------------------|-----------------|---------------------|----------------------|
| 1 O-ring | 7 Non-standard clamp | 13 Intermediate | 19 Positioning pins | 25 Washer |
| 2 Mechanical static ring | 8 Needle roller bearing | 14 Plug | 20 O-ring | 26 Bolt |
| 3 O-ring | 9 Parallel Key | 15 O-ring | 21 Inner rotor | 27 Oil port plug cap |
| 4 Mechanical dynamic ring | 10 Transmission shaft | 16 Spring | 22 Outer rotor | |
| 5 Washer | 11 Screw | 17 Steel ball | 23 Cylindrical pin | |
| 6 Compression spring | 12 Front cover | 18 Valve base | 24 Rear cover | |



Specifications

Type	GGM3.6	GGM6.1	GGM7.4
Displacement in ³ /rev [cm ³ /rev]	0.218 (3.57)	0.372 (6.094)	0.450 (7.374)
Max. Rated RPM	5000	5000	5000
Rated Flow Per 1000 RPM (Nominal)	0.95GPM(3.6 L/min)	1.61GPM(6.1 L/min)	1.95GPM(7.4 L/min)
Max. Continuous Pressure	2000PSI(138.0 bar)	2000PSI(138.0 bar)	2000PSI (138.0 bar)
Max. Intermittent Pressure	2500PSI(172.5 bar)	2500PSI(172.5 bar)	2500PSI (172.5 bar)
Output Torque Per 1000 PSI (69.0 bar)	35 in.-lbs (40 kg-cm)	59 in.-lbs (68 kg-cm)	72 in.-lbs. (83 kg-cm)
Weight	2.8 lbs (1.25 kg)	3.0 lbs (1.36 kg)	3.1 lbs (1.41 kg)
Shaft Side Load**	170 lbs(77.0 kg)	130 lbs(59.0 kg)	110 lbs(50.0 kg)

Type	GGM9.5	GGM11.5
Displacement in ³ /rev [cm ³ /rev]	0.580(9.50)	0.700 (11.471)
Max. Rated RPM	5000	5000
Rated Flow Per 1000 RPM (Nominal)	2.51GPM(9.5 L/min)	3.03GPM(11.5 L/min)
Max. Continuous Pressure	2000PSI (138.0 bar)	1500PSI (103.5 bar)
Max. Intermittent Pressure	2500PSI (172.5 bar)	2000PSI (138.0 bar)
Output Torque Per 1000 PSI (69.0 bar)	92 in.-lbs. (107 kg-cm)	111 in.-lbs (128 kg-cm)
Weight	3.3 lbs (1.50 kg)	3.5 lbs (1.59 kg)
Shaft Side Load**	70 lbs(31.7 kg)	30 lbs(13.5 kg)

* THEORETICAL

** SIDE LOAD: Maximum Permissible Shaft Side Load at 2500 RPM and 1000 PSI (69.0 bar)
(B-10 Bearing Life of 1000 Hrs.)

OIL TEMPERATURE: Maximum recommended oil temperature 180° F (82.2° C)

OIL VISCOSITY: Recommended viscosity 150 SUS (3.65 engler).

(32 centistokes) Minimum recommended viscosity

60 SUS (2.1 engler) (13 centistokes)

FILTRATION: Minimum recommended filtration 10 Micron.

END THRUST: 80 Lbs. (36.3 kg.) maximum.



Function Diagrams

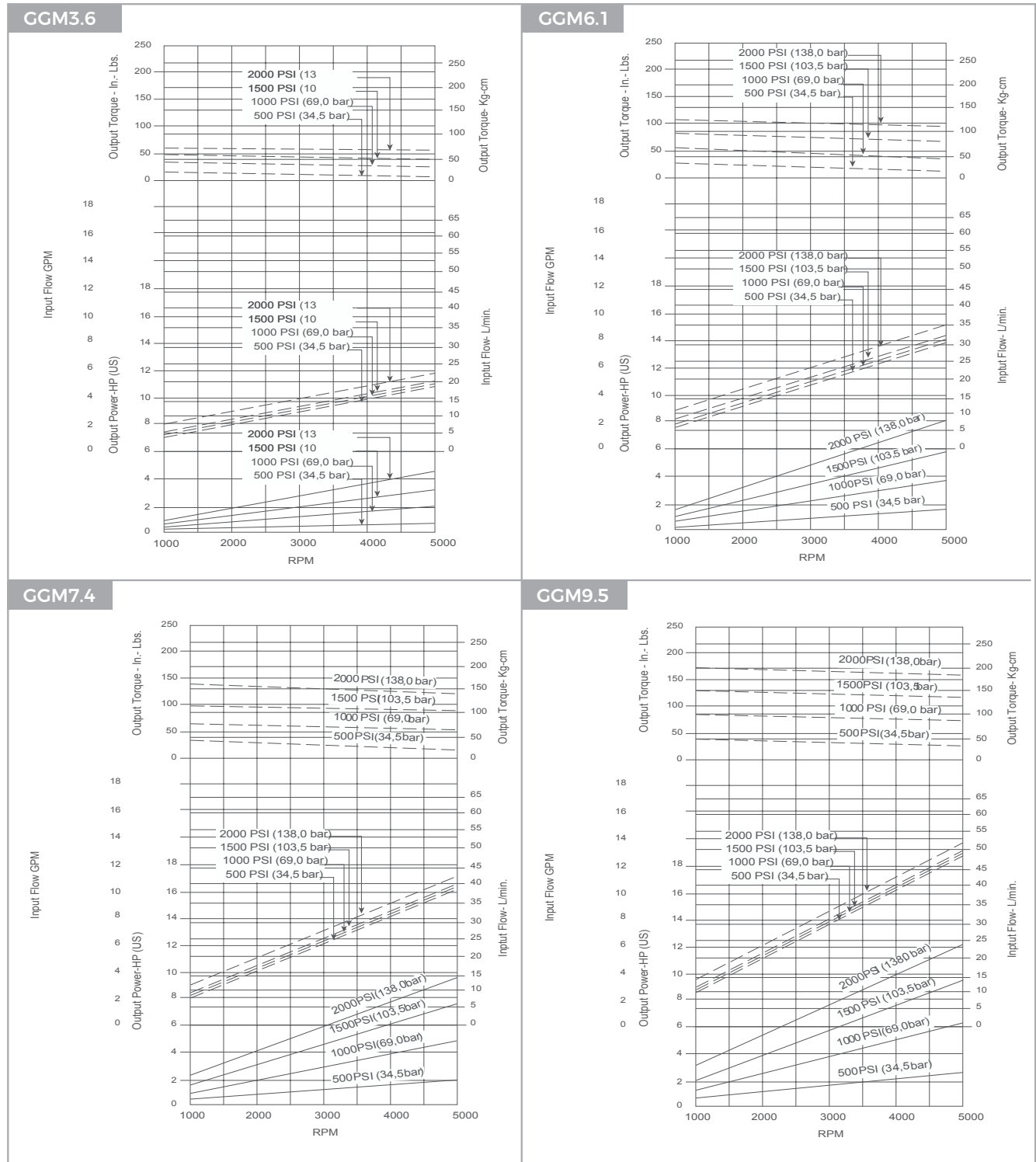

Function Diagrams

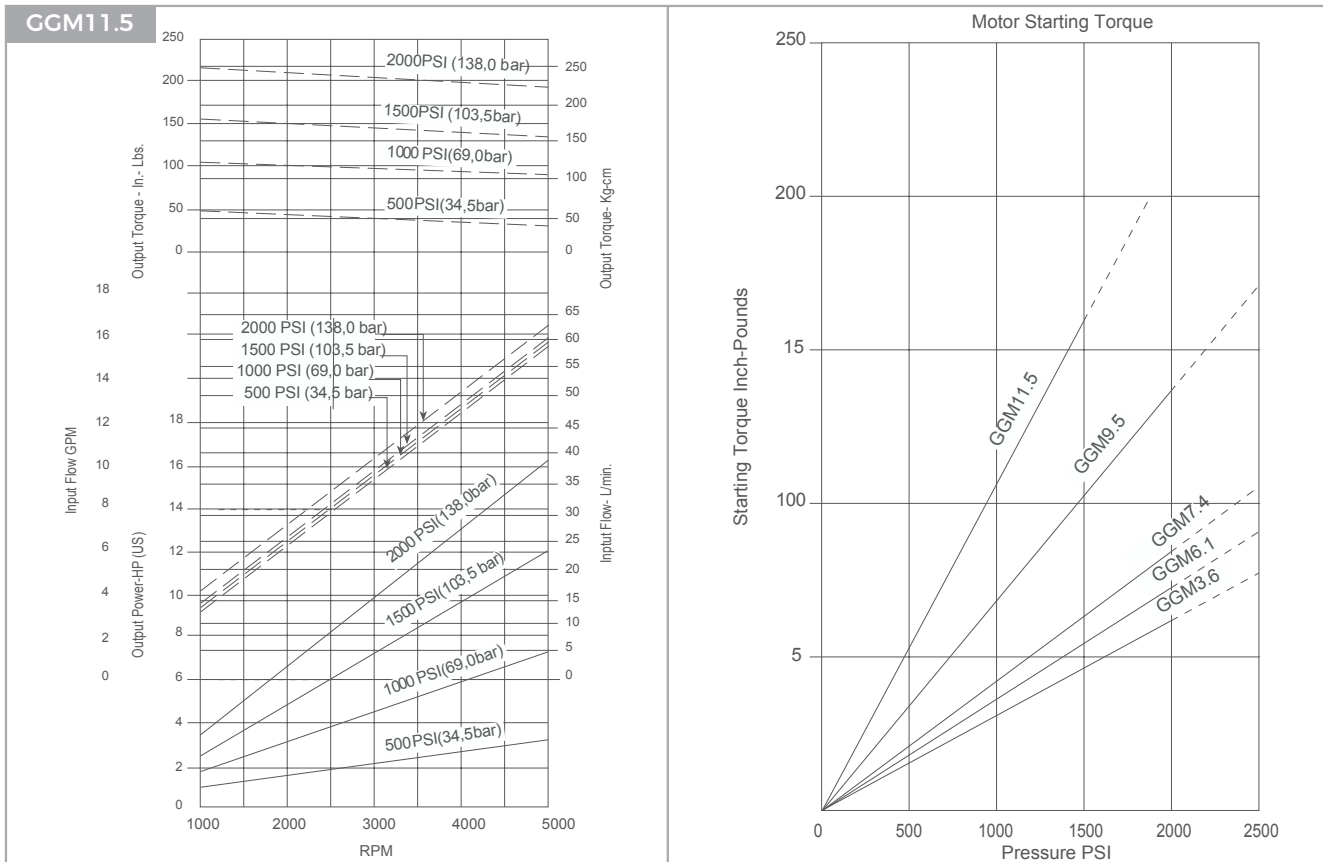

GGM Dimensions and Mountings

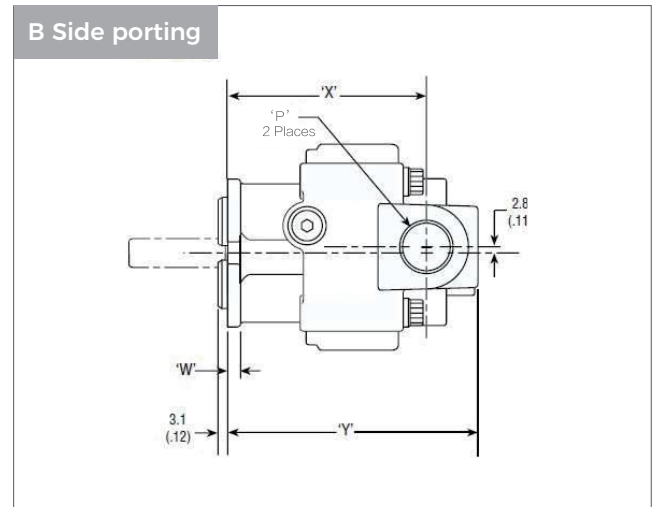
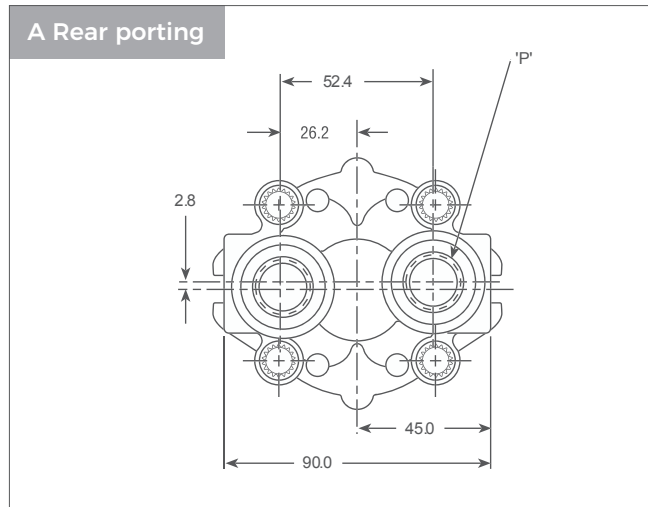

Model	Size	
	"X"	"Y"
GGM3.6	73.1(2.88)	93.1(3.67)
GGM6.1	77.3(3.04)	97.3(3.83)
GGM7.4	79.4(3.13)	99.4(3.91)
GGM9.5	83.0(3.27)	103.0(4.06)
GGM11.5	86.3(3.40)	106.3(4.19)

Flange	"W"
2 holes "SAE A-A"	6.3
4 holes	6.3
2 holes "SAE A"	9.5

Model	"P" SAE Straight thread oil port, O-ring seal
GGM3.6	SAE 8(3/4-16UNF)
GGM6.1	SAE 8(3/4-16UNF)
GGM7.4	SAE 8(3/4-16UNF)
GGM9.5	SAE 10(7/8-14UNF)
GGM11.5	SAE 10(7/8-14UNF)

GGM Flange Covers Dimensions

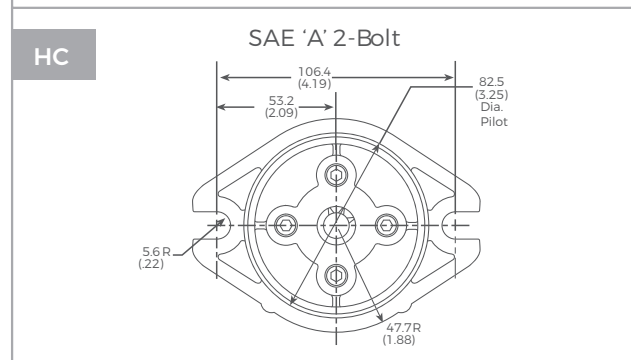
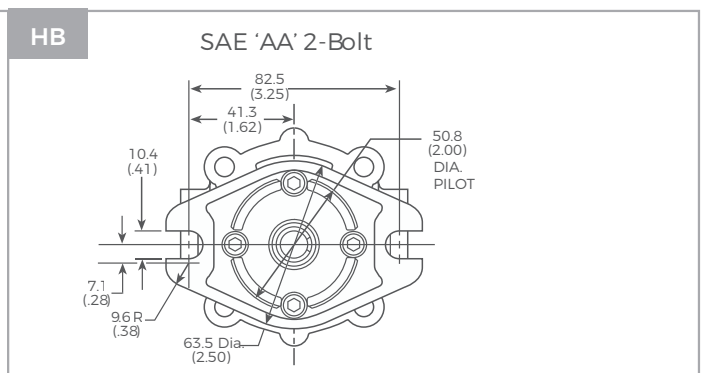
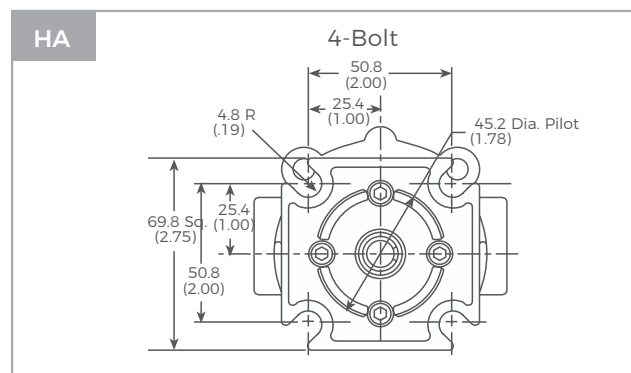

GGM Shafts Dimensions

<p>SQ</p> <p>Flat key shaft $\varnothing 9/16$ Max. allowable torque 52.9Nm</p>	<p>RD</p> <p>Spline shaft 8 teeth $\varnothing 9/16$ Flat tooth side fit-Class 2 Max. allowable torque 52.9Nm</p>
<p>SR</p> <p>Flat key shaft $\varnothing 5/8$ Max. allowable torque 25.8Nm Standard model(recommended)</p>	<p>RG</p> <p>Spline shaft 9 teeth $\varnothing 9/16$ Flat tooth side fit-Class 2 Max. allowable torque 52.9Nm Standard model (recommended)</p>
<p>RF</p> <p>Spline shaft 9 teeth $\varnothing 5/8$ Flat tooth side fit-Class 1 Max. allowable torque 70.5Nm Standard model (recommended)</p>	



GKM Series Hydraulic Motors

Options

- Flange connection
- Motor with needle roller bearing
- Side and rear ports
- Shaft seal for high and low pressure
- Straight, splined and tapered shafts
- Metric and BSPP ports
- Other special features

Applications

- Agricultural augers, harvesters, seeders
- Car wash tire spray wands and brushes
- Marine bow thrusters
- Food processing
- Snow blower chute rotator
- Conveyors



General

Max.Displacement	cm ³ /rev [in ³ /rev]	50 [3.0]
Max.Speed	RPM	1992
Max.Torque	daNm [lb-in]	cont.:84[743] int.:62[549]
Max.Output	kW [HP]	86[765]
Max.Pressure Drop	bar [PSI]	cont.:165[2400] int.:140[2030]
Max.Oil Flow	lpm [GPM]	25[6.5]
Pressure fluid		Mineral based-HLP (DIN 51524) or HM (ISO 6743/4)
Temperature Range	°C [°F]	-34–82[-93–180]
Optimal Viscosity range	mm ² /s [SUS]	Premium quality, anti-wear type hydraulic oil with a viscosity of not less than 13 cSt [70 SUS] at operating temperature.
Filtration		Per ISO Cleanliness Code 4406, level 20/18/13

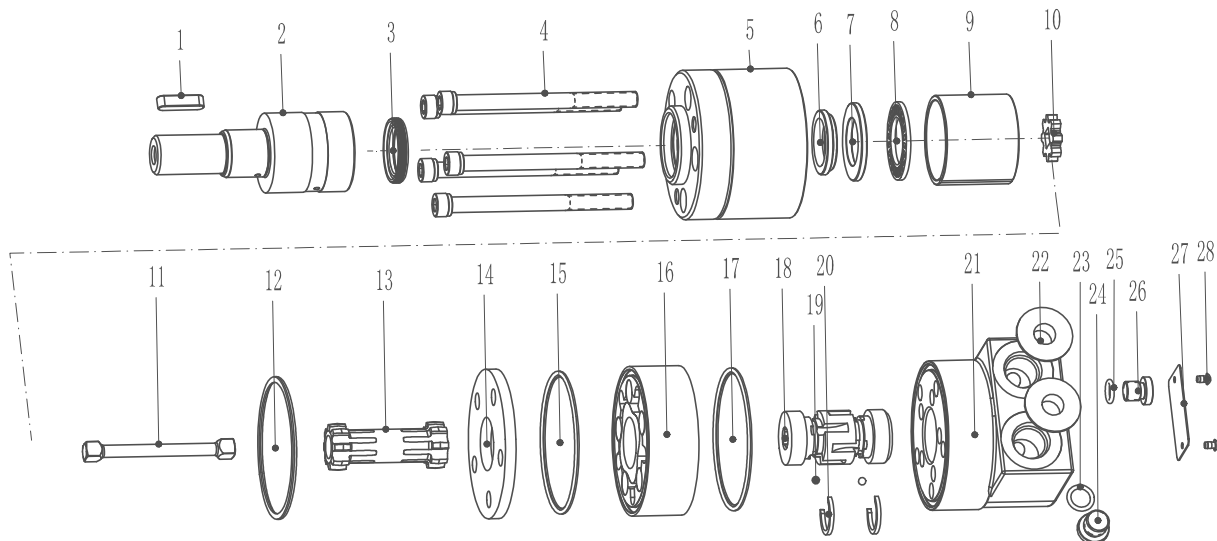

- | | | | | |
|---------------------|--------------------------------|--------------------------------|--------------------------------|-----------------------|
| 1 Flat key | 7 Bearing retaining ring | 13 Transmission shaft | 19 Steel ball | 25 O-Ring |
| 2 Output shaft | 8 Plane needle roller bearings | 14 Spacer | 20 Valve core retaining spring | 26 5/16 - 24 UNF plug |
| 3 Anti-dust cover | 9 DU bearing | 15 Special-shaped sealing ring | 21 rear housing | 27 Nameplate |
| 4 Screw | 10 Spline spacers | 16 Rotor and stator | 22 Oil port plug | 28 Rivet |
| 5 Front housing | 11 Valve core connecting rod | 17 Special-shaped sealing ring | 23 O-Ring | |
| 6 Skeleton oil seal | 12 Special-shaped sealing ring | 18 Flow control valve core | 24 3/8 - 24UNF plug | |

GKM Specifications

Type		GKM8	GKM12.5	GKM20	GKM32	GKM50
Displacement cm ³ /rev [in ³ /rev]		8.2[0.50]	12.9[0.79]	19.8[1.21]	31.6[1.93]	50.0[3.00]
Max.Speed RPM	Int.	1992	1575	1043	650	393
Max.Oil Flow	Cont.	17[4.5]	21[5.5]	21[5.5]	21[5.5]	21[5.5]
lpm [GPM]	Int.	21[5.5]	25[6.5]	25[6.5]	25[6.5]	25[6.5]
Max.Differential Pressure	Cont.	140[2030]	140[2030]	140[2030]	121[1750]	97[1400]
bar [PSI] Int.	Int.	165[2400]	165[2400]	165[2400]	150[2175]	140[2030]
Max.Supply Pressure bar [PSI]		220[3190]	220[3190]	220[3190]	190[2756]	150[2175]
Max.Torque	Cont.	16[141]	25[225]	38[333]	50[446]	62[549]
daNm [lb-in]	Int.	19[164]	30[263]	46[405]	62[546]	84[743]
Max.Performance kW [HP]		22[193]	36[321]	48[425]	83[733]	86[765]
Weight.kg [lb]		2[4.4]	2.1[4.6]	2.2[4.8]	2.3[5.0]	2.4[5.4]

GKM Dimensions and Mountings

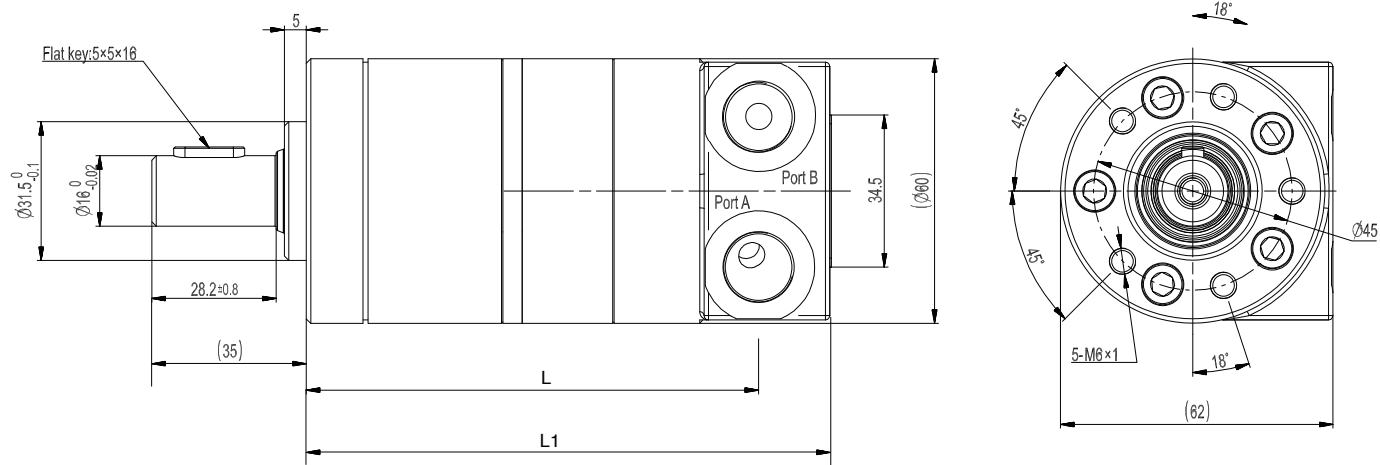

Side

Model	L(mm)	L1(mm)
8	103.9	87.4
12.5	106.9	90.4
20	112.5	94.7
32	118.9	102.4
50	130.0	113.9

End port

Model	L(mm)
8	103.9
12.5	106.9
20	112.5
32	118.9
50	130.0
160	132.3

Mounting	GA (depth)	U8 (depth)	GB (depth)	U9 (depth)
P(A, B)	G3/8(12)	9/16-18UNF(12)	Rear oil port G3/8(12)	Rear oil port 9/16-18UNF(12)
T	G1/8(8)	3/8-24UNF(8)	G1/8(8)	3/8-24UNF(8)

GKM Flange Covers Dimensions

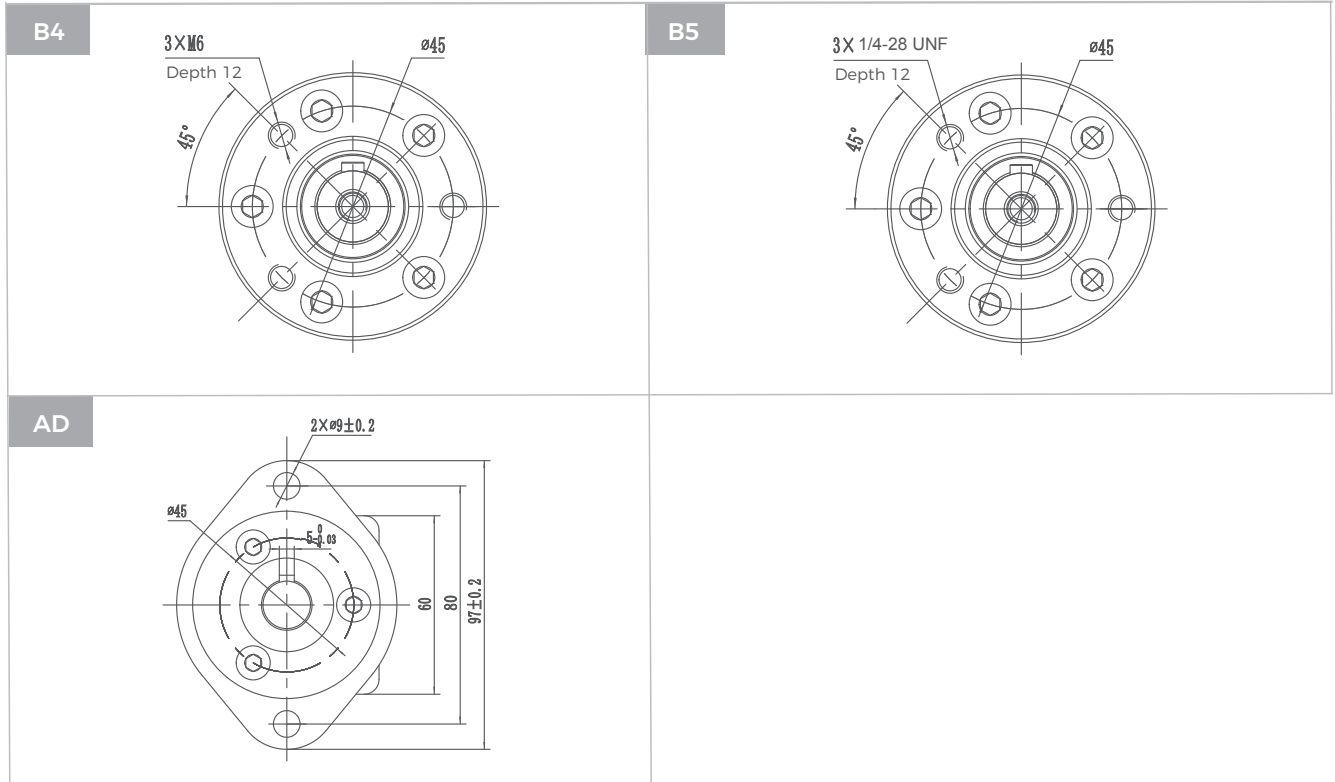

GKM Shafts Dimensions

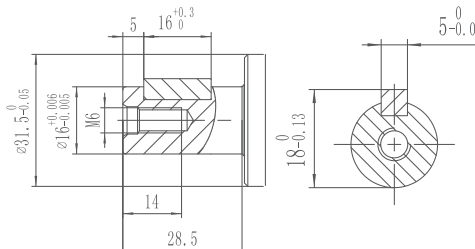
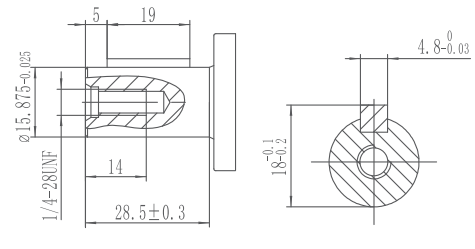
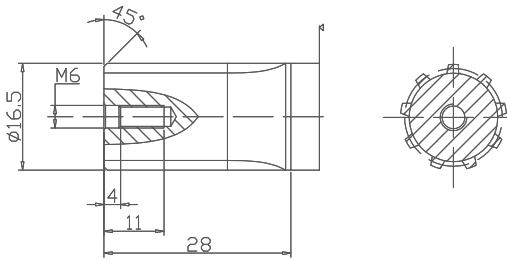
<p>SG</p>  <p>Straight shaft $\varnothing 16$ Parallel key 5 x 5 x 16</p>	<p>TF</p>  <p>Straight shaft $\varnothing 15.875$ Parallel key 4.8 x 4.8 x 19.05</p>
<p>S4</p>  <p>Splined shaft $\varnothing 16.5$ B7 x 14 DIN5482</p>	

GKA Series Hydraulic Motors

Options

- Flange and circle
- Bearingless motor
- Motor with brake
- Tacho connection
- Speed sensing
- Side and rear ports
- Straight, splined and tapered shafts
- Shaft seal for high and low pressure
- Metric and BSPP ports
- Other special features

Applications

- Conveyors
- Paver
- Metal working machines
- Special vehicles
- Agricultural machines
- Food industries
- Mining machines







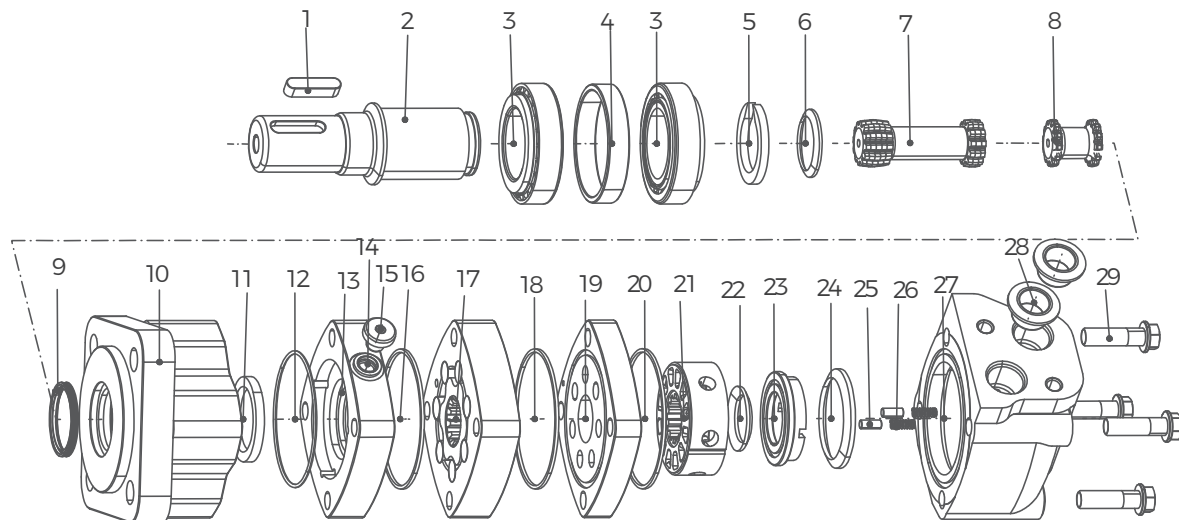





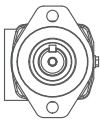



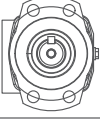

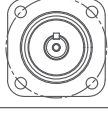
General

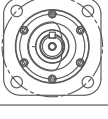
Max. Displacement	cm ³ /rev [in ³ /rev]	490 [29.8]
Max. Speed	RPM	1215
Max. Torque	daNm [lb-in]	cont.: 84,5 [7470] int.: 93,0 [8225]
Max. Pressure Drop	bar [PSI]	cont.: 205 [3000] int.: 310 [4500]
Max. Oil Flow	lpm [GPM]	150 [30]
Pressure Fluid		Mineral based- HLP (DIN 51524) or HM (ISO 6743/4)
Temperature Range	°C [°F]	-40-140 [-104-284]
Optimal Viscosity range	mm ² /s [SUS]	20-75 [98-347]
Filtration		ISO code 20/16 (Min. recommended fluid filtration of 25 microns)



- | | | | | |
|--------------------------|----------------------|-----------------------|----------------------------|----------------------|
| 1 Parallel Key | 7 Transmission shaft | 13 Connecting body | 19 Balance plate | 25 Positioning pins |
| 2 Output shaft | 8 Coupling shaft | 14 Sealing gasket | 20 Special shape ring | 26 Spring |
| 3 Tapered roller bearing | 9 Anti-dust ring | 15 Plug | 21 Flow distribution plate | 27 Rear housing |
| 4 Bearing retainer ring | 10 Front Cover | 16 O-ring | 22 Special shape ring | 28 Oil port plug cap |
| 5 Washers | 11 Shaft seal | 17 Rotor and stator | 23 Flow pressure plate | 29 Screw |
| 6 Special shape ring | 12 O-ring | 18 Special shape ring | 24 Special shape ring | |

Ordering Code

GKA SERIES		DISP	FLANGE	SHAFT	PORTS	ROTATION	PAINT	FUNCTION	
CODE	DISP cm ³ /rev in ³ /rev	CODE	FLANGE	CODE	SHAFT	CODE	ROTATION	CODE	FUNCTION
34	34 [2.1]	A7	2-Hole SAE A pilot Ø82.5×6.4 	R6	Ø31.25 Splined 14-DP 12/24 	A	Standard	A	Standard
41	41 [2.5]	H3	4- Ø13.5 Square pilot Ø82.5×6.4 	S6	Ø25.4 woodruff key Ø25.4×6.35 	R	Opposite	B	Blue
66	66 [4.0]	A9	4-Hole SAE A pilot Ø82.5×6.4 	R8	Ø25.4 splined SAE 6B 	C	Black	S	Silver grey
80	80 [4.9]	W1	4- Ø13.5 Square pilot Ø107.95×46.5 	S1	Ø25 parallel key 8×7×32 	A	No paint	A	Standard
90	90 [5.5]	W2	4- Ø13 Square pilot Ø100×6.5 	R5	Ø22 Splined 13-DP 16/32 	N	Big radial force	D	No case drain
100	100 [6.2]			S4	Ø32 parallel key 10×8×45 	F	Free running	F	Free running
130	130 [8.0]			T2	Tapered 1:8 Ø31.75 parallel key 7.96×7.96×25.4 	L	Low speed	L	Low speed
160	160 [9.6]			SG	Ø31.75 parallel key 7.96×7.96×31.75 	V	High temp.	V	High temp.
195	195 [11.9]			A1	Ø25 parallel key 8×7×2 	S	Low temp.	S	Low temp.
245	245 [14.9]			N	Ø30 Splined 6-30×25×6 				
305	305 [18.7]			Z	Ø32 Splined 6-32×26×6 				
495	395 [24.0]			RQ	Ø30 Splined 6-30×25×8 				
490	490 [29.8]								
				CODE	PORTS				
				G7	G1/2, G1/4				
				DU	G1/2, 7/16-20 UNF				
				U9	7/8-14 O-ring, 7/16-20 UNF				
				SB	7/8-14, O-ring G1/4				
				M4	M22x1.5, M14x1.5				
				MU	Ø12.7, Ø15.8, 7/16-20 UNF manifold 3x3/8-16 UNC				
				MM	Ø12.7Ø15.8, G1/4 manifold M10x1				

Specifications

Type		GKA34	GKA41	GKA66	GKA80	GKA90
Displ. cm ³ /rev [in ³ /rev]		34[2.1]	41[2.5]	66[4.0]	80[4.9]	90[5.5]
Max. Speed	Cont.	1215	1104	1075	908	836
RPM	Int.*	1215	1216	1214	908	1042
Flow	Cont.	42[11]	45[12]	72[19]	75[20]	75[20]
lpm [GPM]	Int.*	42[11]	53[14]	87[23]	75[20]	95[25]
Torque	Cont.	9.8[864]	11.2[988]	18.6[1643]	23.5[2065]	26.5[2326]
daNm [lb - in]	Int.*	14.2[1261]	16.9[1497]	27.6[2446]	34.5[3035]	39.0[3458]
Pressure	Cont.	205[3000]	205[3000]	205[3000]	205[3000]	205[3000]
bar [PSI]	Int.*	310[4500]	310[4500]	310[4500]	310[4500]	310[4500]
	Peak**	310[4500]	310[4500]	310[4500]	310[4500]	310[4500]
Weight kg [lb]	Standard or Wheel mount	8.8[19.4]	8.8[19.4]	8.8[19.4]	9.3[20.5]	9.3[20.5]
	Bearingless	6.8[15.0]	6.8[15.0]	6.8[15.0]	7.3[16.0]	7.3[16.0]

Type		GKA100	GKA130	GKA160	GKA195	GKA245
Displ. cm ³ /rev [in ³ /rev]		100[6.2]	130[8.0]	160[9.6]	195[11.9]	245[14.9]
Max. Speed	Cont.	742	576	477	385	308
RPM	Int.*	924	720	713	577	462
Flow	Cont.	75[20]	75[20]	75[20]	75[20]	75[20]
lpm [GPM]	Int.*	95[25]	95[25]	115[30]	115[30]	115[30]
Torque	Cont.	29.5[2630]	38.5[3420]	45.5[4040]	54.0[4780]	66.0[5850]
daNm [lb - in]	Int.*	44.5[3950]	56.0[4970]	57.0[5040]	66.5[5890]	82.0[7250]
Pressure	Cont.	205[3000]	205[3000]	205[3000]	205[3000]	205[3000]
bar [PSI]	Int.*	310[4500]	310[4500]	260[3750]	260[3750]	260[3750]
	Peak**	310[4500]	310[4500]	310[4500]	310[4500]	310[4500]
Weight kg [lb]	Standard or Wheel mount	9.5[21.0]	9.8[21.5]	10.0[22.0]	10.4[23.0]	11.3[25.0]
	Bearingless	7.5[16.5]	7.7[17.0]	7.9[17.5]	8.4[18.5]	9.3[20.5]

Type		GKA305	GKA395	GKA490
Displ. cm ³ /rev [in ³ /rev]		305[18.7]	395[24.0]	490[29.8]
Max. Speed	Cont.	246	191	153
RPM	Int.*	265	335	230
Flow	Cont.	75[20]	75[20]	75[20]
lpm [GPM]	Int.*	115[30]	115[30]	115[30]
Torque	Cont.	76.5[6750]	77.5[6840]	84.5[7470]
daNm [lb - in]	Int.*	88.5[7820]	92.5[2250]	93.6[8225]
Pressure	Cont.	205[3000]	155[2250]	120[1750]
bar [PSI]	Int.*	240[3500]	190[2750]	140[2000]
	Peak**	310[4500]	225[3250]	170[2500]
Weight kg [lb]	Standard or Wheel mount	11.3[25.0]	11.8[26.0]	12.2[27.0]
	Bearingless	9.3[20.5]	9.8[21.5]	10.2[22.5]

GKA Dimensions and Mountings

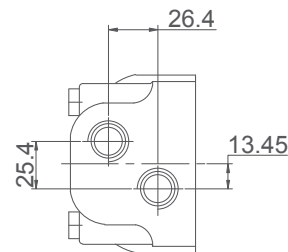
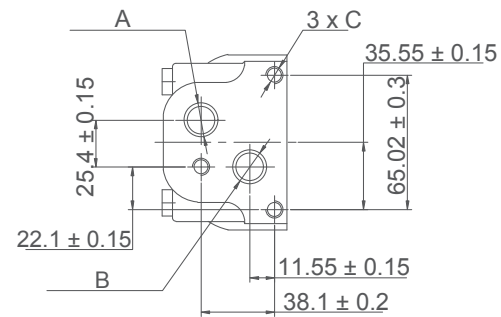
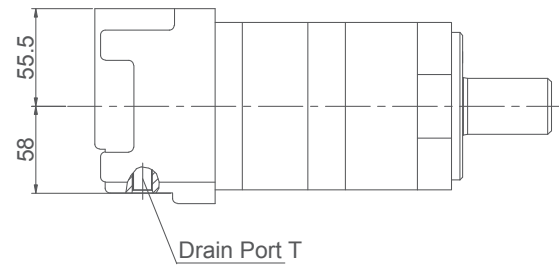
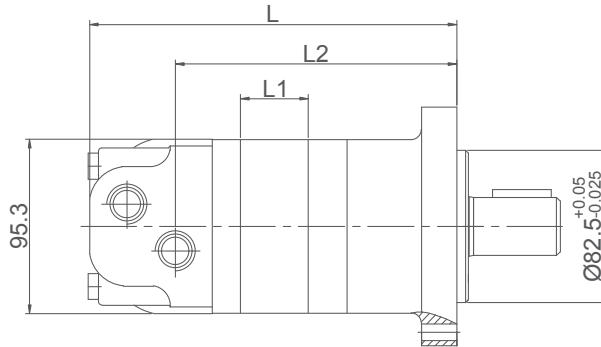

Model	L(mm)	L1(mm)	L2(mm)
GKA34	182	14.5	133.5
GKA41	185	17.8	136.5
GKA66	189.5	22.5	141.5
GKA80	196	28.9	148
GKA90	196	28.9	148
GKA100	202.5	35.6	154.5
GKA130	211.5	44.6	163.5
GKA160	223	56	175
GKA195	235.3	72	188.3
GKA245	256.5	89.3	208.5
GKA305	277.8	107.8	212.5
GKA395	296.5	125.5	237.5
GKA490	313.8	142.3	245

Mounting	G7 (depth)	DU (depth)	U9 (depth)	SB (depth)	M4 (depth)	MU (depth)	MM (depth)
P(A, B)	G1/2 (15)	G1/2 (15)	7/8-14 O-ring (17)	7/8-14 O-ring (17)	M22 x 1.5 (15)	Ø12.7, Ø15.8	Ø12.7, Ø15.8
T	G1/4(12)	7/16-20 UNF (12)	7/16-20 UNF (12)	G1/4 (12)	M14 x 1.5 (12)	7/16-20 UNF (12)	G1/4 (12)
C	—	—	—	—	—	3/8-16 UNC (15)	M10 x 1(15)

GKA with Brake Dimensions and Mountings

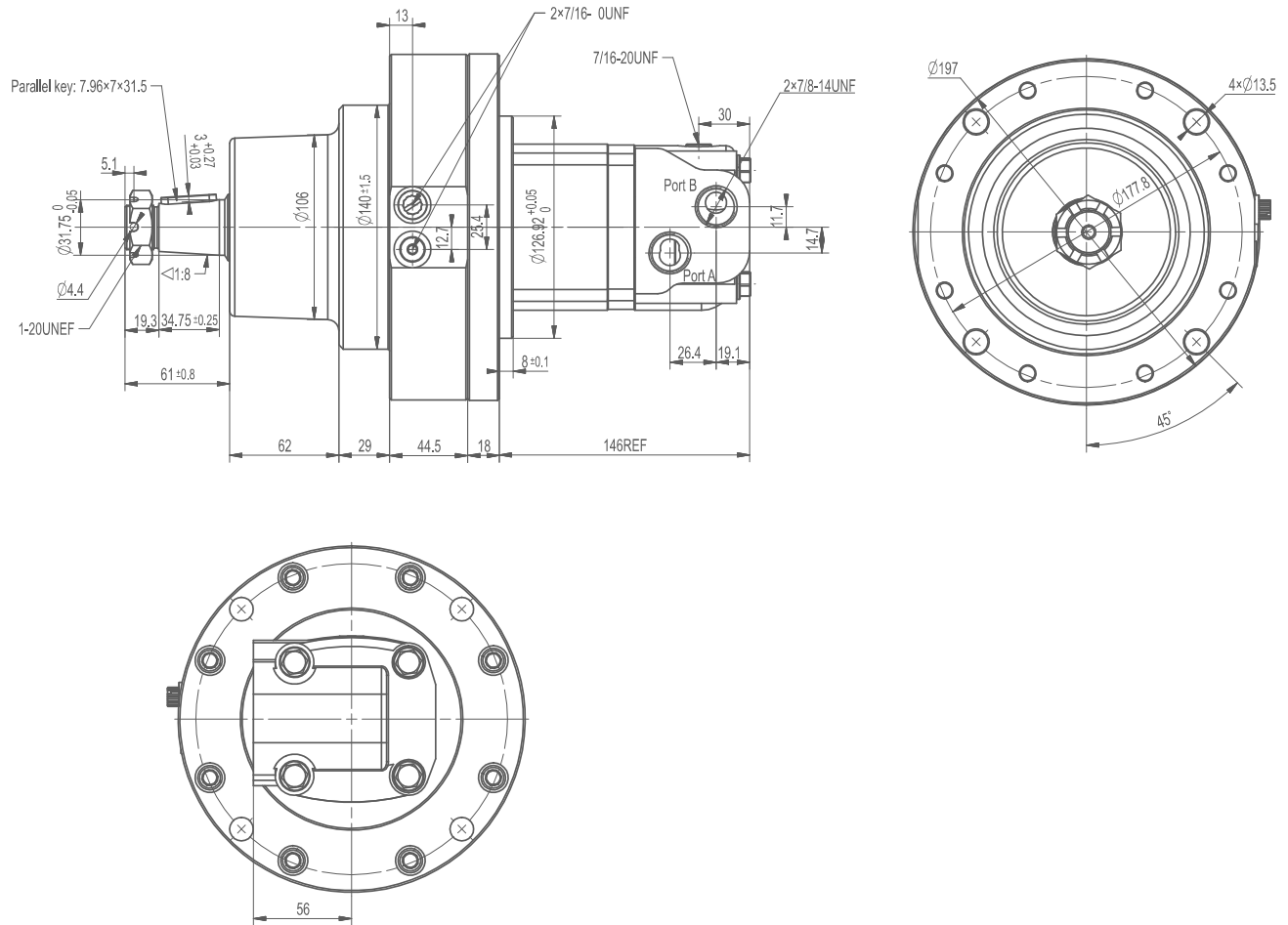

DISPLACEMENT	293cm ³ /rev
MAX.CONTINUOUS RATING PRESSURE	20.5MPa
BRAKE TORQUE	1130Nm
THE BRAKE RELEASE PRESSURE	2.8MPa,Max
RELEASE PRESSURE	20.7MPa,Max
WORKING TEMPERATURE	82°C
PAINT	BLACK

Nominal working temperature is 30-60°C,max.working temperature is 82°C

the temperature range of HNBR seal is -40 to 150°C

Initial brake release pressure is 2.8MPa.Full release pressure is 3.0MPa

GKA Flange Covers Dimensions

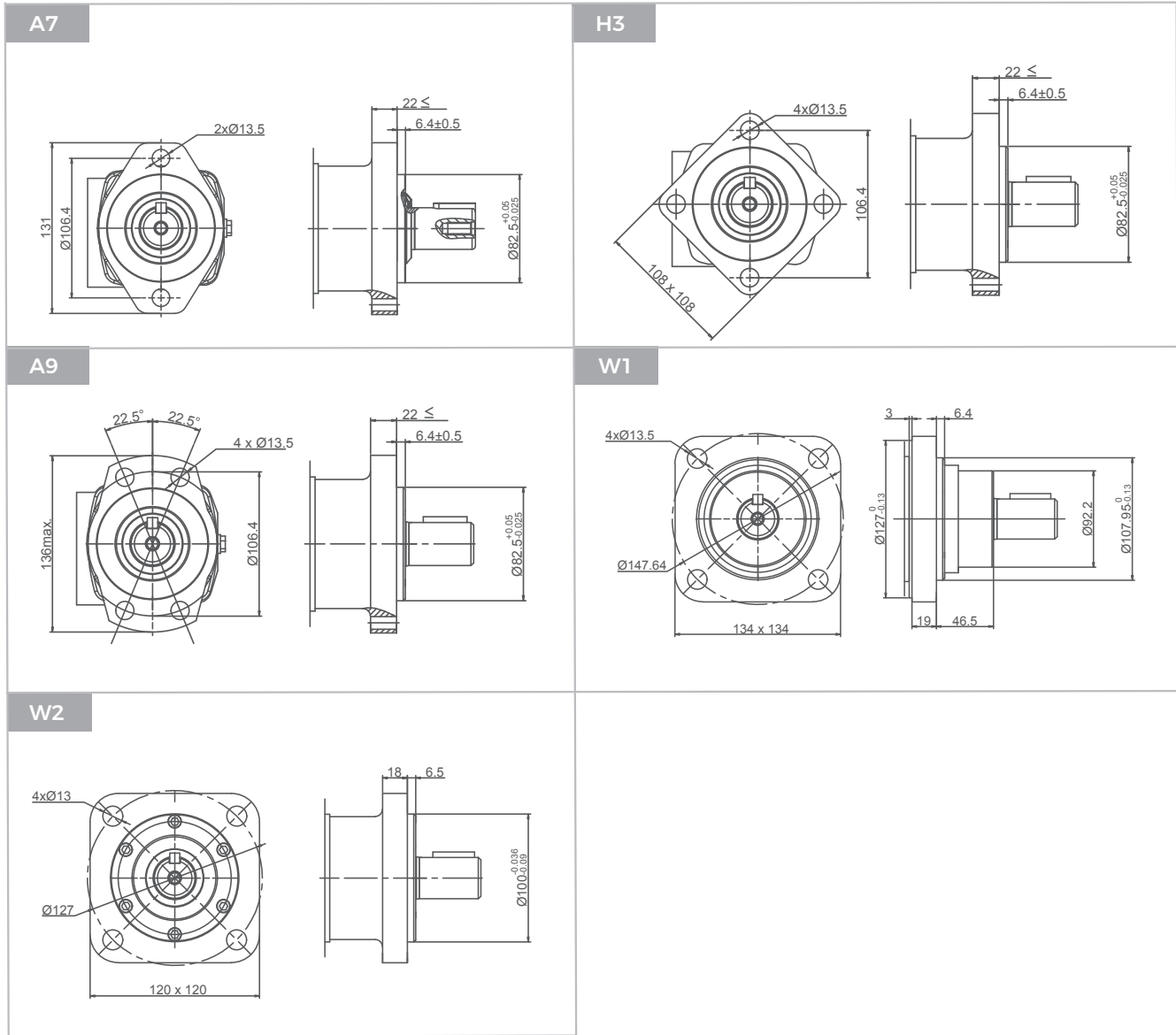



GKA Shafts Dimensions

<p>R6</p> <p>3/8-16UNC</p> <p>Ø31.25</p> <p>47.5</p> <p>35</p> <p>20</p> <p>56</p> <p>Ø28.25</p> <p>Splined shaft 14-DP 12/24</p>	<p>S6</p> <p>6.35^{+0.025}₀</p> <p>Ø25.4</p> <p>41.5</p> <p>18.5±0.5</p> <p>15±1</p> <p>50</p> <p>1/4-20UNC</p> <p>28.3±0.3</p> <p>Straight shaft Ø25.4 Woodruff key 25.4 x 6.35</p>
<p>R8</p> <p>6-6.25±0.05</p> <p>Ø21.47±0.07</p> <p>1/4-20UNC</p> <p>41.5 ≥</p> <p>23</p> <p>15</p> <p>50</p> <p>Ø25.4±0.10</p> <p>Ø21</p> <p>Splined shaft Ø25.4 SAE 6B</p>	<p>S1</p> <p>8⁰_{±0.036}</p> <p>Ø25±0.03</p> <p>4</p> <p>32</p> <p>18</p> <p>41.5</p> <p>50</p> <p>M8</p> <p>28±0.3</p> <p>Straight shaft Ø25 Parallel key 8 x 7 x 32</p>
<p>R5</p> <p>31.5</p> <p>Ø22±0.1</p> <p>13±0.5</p> <p>40</p> <p>Ø18.5±0.1</p> <p>Splined shaft 13-DP 16/32</p>	<p>S4</p> <p>10⁰_{±0.036}</p> <p>Ø32^{+0.018}_{-0.002}</p> <p>5</p> <p>45</p> <p>18</p> <p>57.5</p> <p>65</p> <p>M8</p> <p>35±0.3</p> <p>Straight shaft Ø32 Parallel key 10 x 8 x 45</p>

GKA Shafts Dimensions

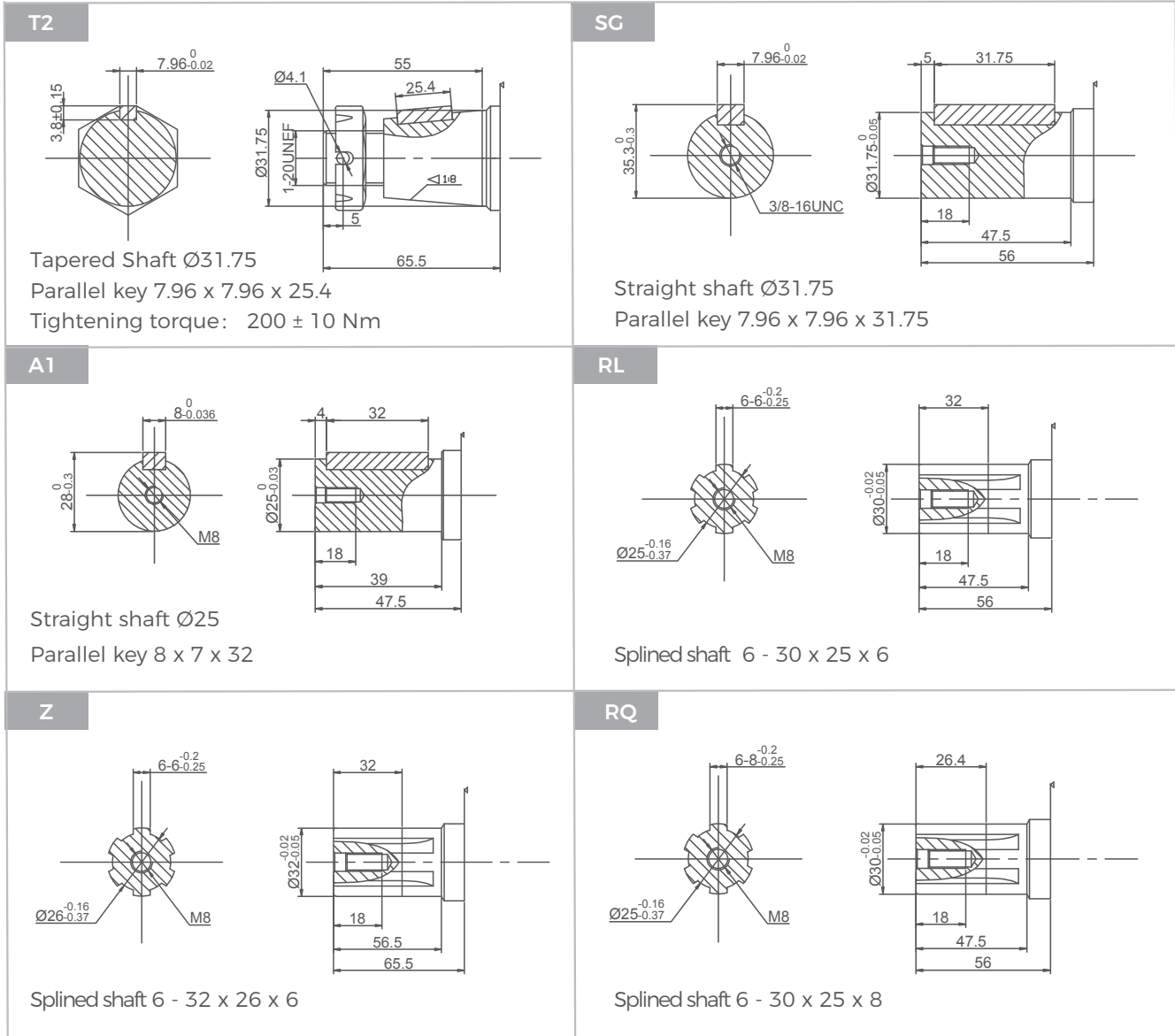

GKA Series Hydraulic Motors

Permissible shaft seal pressure

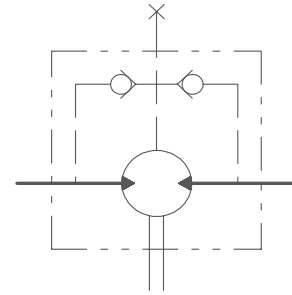
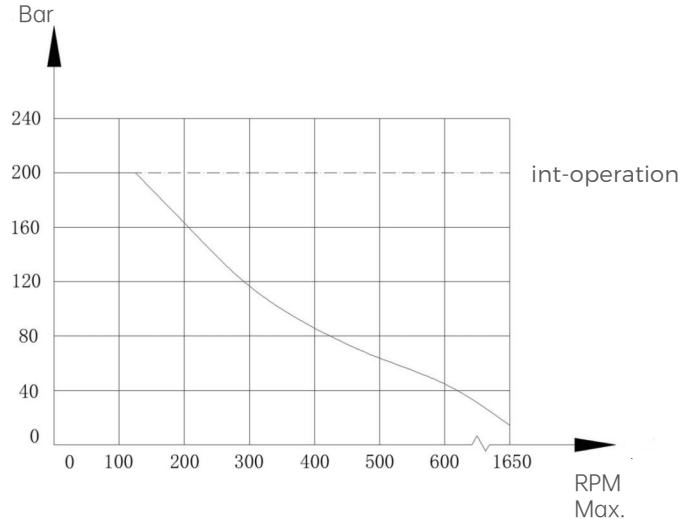

GKA with standard shaft seal check valves and without use of drain connection: The pressure on the shaft seal never exceeds the pressure in the return line.

GKA with standard shaft seal, check valves and with drain connection: The shaft seal pressure equals the pressure on the drain line.

Drain Port

In applications without drain line, output shaft seal exceeds a bit of the pressure in the return line. In applications using the drain line, the pressure of output shaft seal equals the pressure in drain line.

Standard direction of shaft rotation: Standard

When facing shaft end of motor, shaft to rotate:
Clockwise. When port A is pressurized.
Counter-clockwise port B is pressurized.

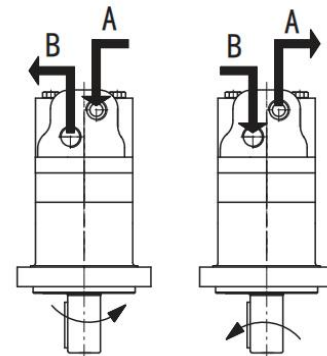

Output shaft axial and radial force

Fr: Radial force

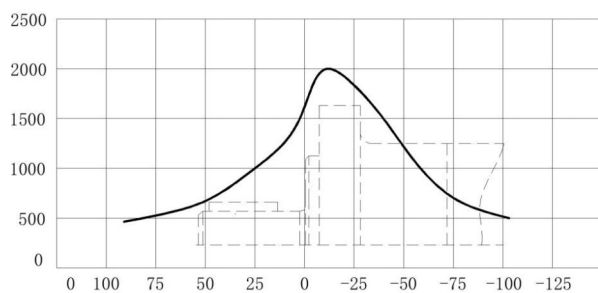

Distance between force and flange surface (mm)

This radial force curve is derived from the permissible bearing life B10 load at rated torque (2,000 hours or 12x10⁶ revolutions at 150 rpm) and must be multiplied by a factor for other speeds.



GKB Series Hydraulic Motors

Options

- Flange connection
- Bearingless motor
- Speed sensing
- Straight, splined and tapered shafts
- Metric and BSPP ports
- Other special features

Applications

- Metal working machines
- Agricultural machines
- Road building machines
- Mining machines
- Food industries
- Special vehicles
- Injection molding machines
- Conveyors



General



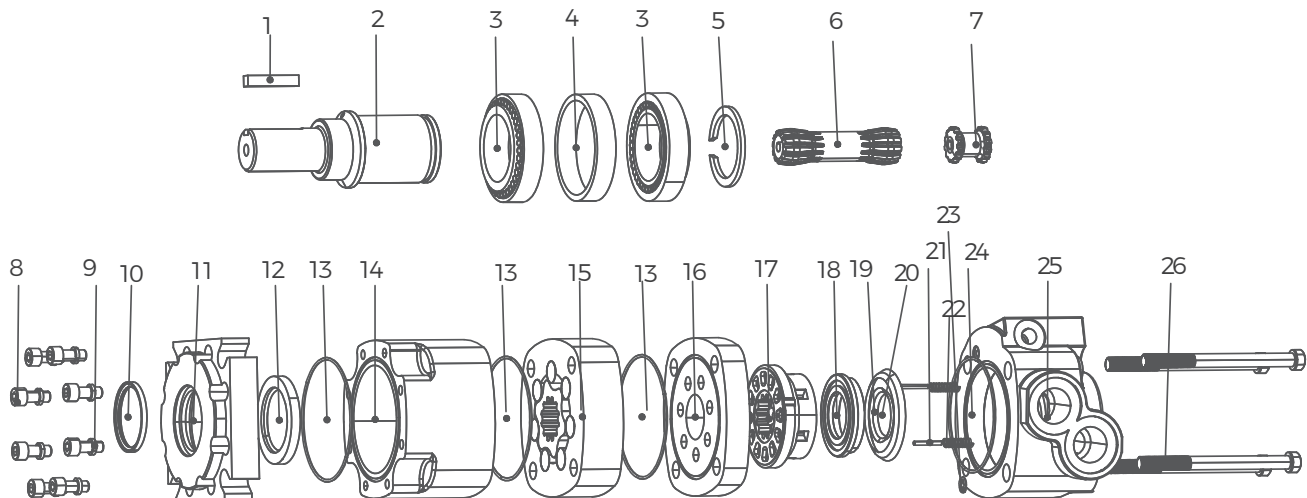



Max. Displacement	cm ³ /rev [in ³ /rev]	625 [38.0]
Max. Speed	RPM	697
Max. Torque	daNm [lb-in]	cont.: 97,2 [8605] int.: 118,1 [10450]
Max. Pressure Drop	bar [PSI]	cont.: 205 [3000] int.: 310 [4500]
Max. Oil Flow	lpm [GPM]	150 [40]
Pressure Fluid		Mineral based- HLP (DIN 51524) or HM (ISO 6743/4)
Temperature Range	°C [°F]	-40-140 [-104-284]
Optimal Viscosity range	mm ² /s [SUS]	20-75 [98-347]
Filtration		ISO code 20/16 (Min. recommended fluid filtration of 25 microns)

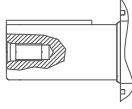

- | | | | | |
|-------------------------------|----------------------|---------------------|----------------------------|---------------------|
| 1 Flat key | 6 Transmission shaft | 11 Flange | 16 Balance plate | 21 Positioning pins |
| 2 Output shaft | 7 Coupling shaft | 12 Shaft seal | 17 Flow distribution plate | 22 Spring |
| 3 Tapered roller bearing | 8 Bolt | 13 Sealing gasket | 18 Flow pressure plate | 23 O-ring |
| 4 Bearing outer retainer ring | 9 Spring washer | 14 Rear housing | 19 Inner butterfly ring | 24 O-ring |
| 5 Washers | 10 Anti-dust ring | 15 Rotor and stator | 20 Outer butterfly ring | 25 Rear housing |
| | | | | 26 Screw |

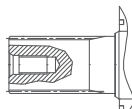

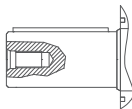
Ordering Code

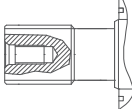
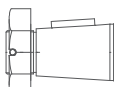
GKB SERIES		DISP	FLANGE		SHAFT		PORTS		ROTATION		PAINT		FUNCTION	
CODE	DISP cm ³ /rev [in ³ /rev]	CODE	FLANGE	CODE	SHAFT	CODE	PORTS	CODE	ROTATION	CODE	PAINT	CODE	FUNCTION	
110	110 [6.7]	H9	4- Ø15 square pilot Ø101.6×9 	SM	Ø31.75 parallel key 7.96×7.96×41 	U5	1-1/16-12 O-ring, 7/16-20UNF	A	Standard	A	No Paint	A	Standard	
130	130 [7.9]	HL	4- Ø14.5 square pilot Ø127×12.3 	RT	Ø31.7 Splined 14-DP 12/24 	UK	7/8-14 O-ring, 9/16-18UNF	R	Opposite	B	Blue	N	Big radial force	
160	160 [9.9]	W7	4- Ø14.5 wheel pilot Ø139.6 	SA	Ø40 paralle key 12×8×70 	MD	M22×1.5, M14×1.5			C	Black	V	High Temp.	
205	205 [12.5]	HM	4- Ø15 bolt (bearingless) pilot Ø127×12.4 	RV	Ø38.1 Splined 17-DP 12/24 	UL	Ø19.05, 7/16-20UNF manifold 3×3/8-16UNC			S	Silver grey	S	Low Temp.	
245	245 [15.0]			TE	Tapered 1:8 Ø41.25 parallel key 11.13×11.13×31.4 									
280	280 [17.1]													
310	310 [19.0]													
395	395 [24.0]													
495	495 [30.0]													
625	625 [38.0]													

Specifications

Type		GKB100	GKB130	GKB160	GKB205	GKB245
Displ. cm ³ /rev [in ³ /rev]		110[6.7]	130[7.9]	160[9.9]	205[12.5]	245[15.0]
Max. Speed	Cont.	626	722	582	459	383
RPM	Int*	697	862	693	546	532
Flow	Cont.	75[20]	95[25]	95[25]	95[25]	95[25]
lpm [GPM]	Int*	95[25]	115[30]	115[30]	115[30]	130[35]
Torque	Cont.	32,2[2850]	37,6[3330]	48,5[4290]	59,9[5300]	70,5[6240]
daN.m [lb - in]	Int*	47,0[4160]	55,8[4940]	70,5[6240]	80,2[7100]	84,4[7470]
Pressure Δ	Cont.	205[3000]	205[3000]	205[3000]	205[3000]	205[3000]
bar [Δ PSI]	Int*	310[4500]	310[4500]	310[4500]	310[4500]	260[3750]
	Peak**	310[4500]	310[4500]	310[4500]	310[4500]	310[4500]
Weight kg [lb]	Standard or Wheel mount	17.9[39.5]	18.1[40.0]	18.1[40.0]	18.4[40.5]	18.6[41.0]
	Bearingless	14.1[31.0]	14.1[31.0]	14.3[31.5]	14.5[32.0]	14.7[32.5]

Type		GKB280	GKB310	GKB395	GKB495	GKB625
Displ. cm ³ /rev [in ³ /rev]		280[17.1]	310[19.0]	395[24.0]	495[30.0]	625[38.0]
Max. Speed	Cont.	336	303	239	191	151
RPM	Int*	468	422	376	305	241
Flow	Cont.	95[25]	95[25]	95[25]	95[25]	95[25]
lpm [GPM]	Int*	130[35]	130[35]	150[40]	150[40]	150[40]
Torque	Cont.	75,3[6666]	85,1[7530]	93,1[8240]	94,6[8375]	97,2[8605]
daNm [lb - in]	Int*	95,7[8471]	106,4[9420]	118,3[10470]	116,9[10350]	118,1[10450]
Pressure	Cont.	205[3000]	205[3000]	190[2750]	140[2000]	115[1700]
bar [PSI]	Int*	260[3750]	260[3750]	240[3500]	170[2500]	140[200]
	Peak**	310[4500]	310[4500]	295[4250]	230[3300]	180[2600]
Weight kg [lb]	Standard or Wheel mount	19.1[42.0]	19.5[43.0]	20.4[45]	21.8[48.0]	23.1[51.0]
	Bearingless	15.2[33.5]	15.6[34.5]	16.6[36.5]	17.9[39.5]	19.3[42.5]

GKB Dimensions and Mountings

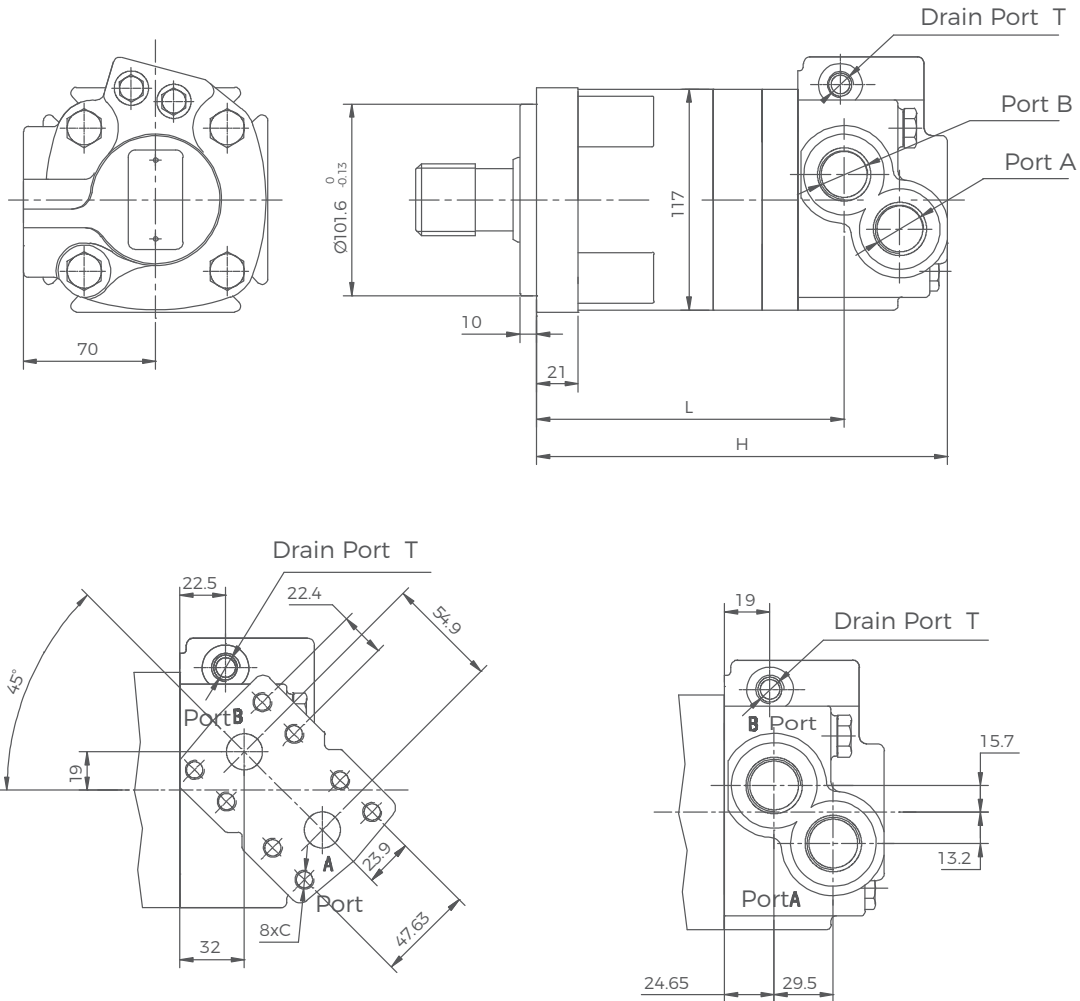

Model	1-1/16-12 or G3/4 Threaded Ports		3/4 Split Flange Oil Ports	
	H	L	H	L
GKB110	214.4	158.3	246.3	166.7
GKB130	218.4	162.3	250.4	170.8
GKB160	224.7	168.7	256.7	177.1
GKB205	233.2	177.2	265.2	185.6
GKB245	224.7	168.7	256.7	177.1
GKB310	233.2	177.2	265.2	185.6
GKB395	243.9	187.9	275.9	196.3
GKB495	256.8	200.7	288.8	209.2
GKB625	273.9	217.8	305.9	226.2

Mounting	U5 (depth)	UK (depth)	MD (depth)	UL (depth)
P(A, B)	1-1/16-12 O-ring	7/8-14 UNF O-ring	M22 x 1.5	2- \varnothing 19.05
T	7/16-20 O-ring	9/16-18 UNF O-ring	M22 x 1.5	7/16-20 UNF
C	—	—	—	3x3/8-16NNC

GKB Wheel Motor Dimensions and Mountings

Flange W7

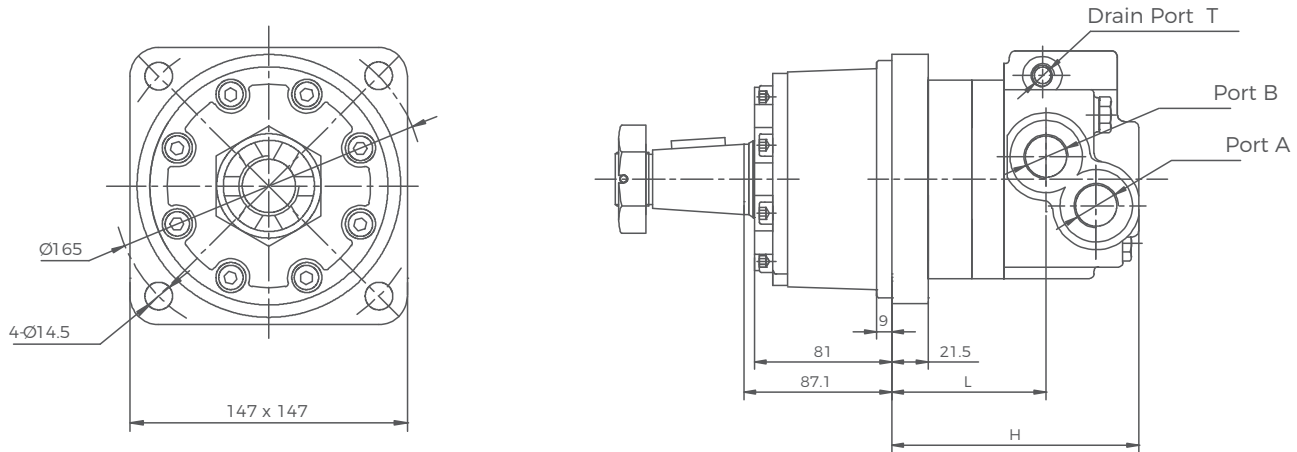

Model	1-1/16-12 or G3/4 Threaded Ports		3/4 Split Flange Oil Ports	
	H	L	H	L
GKB110	143.3	87.4	174.5	95.1
GKB130	147.3	91.5	178.5	99.1
GKB160	153.6	97.8	184.9	105.5
GKB205	162.2	106.3	193.4	114.0
GKB245	153.6	97.8	184.9	105.5
GKB310	162.2	106.3	193.4	114.0
GKB395	172.8	117.0	204.1	124.7
GKB495	185.8	129.9	217.0	137.6
GKB625	202.8	147.0	234.0	154.6

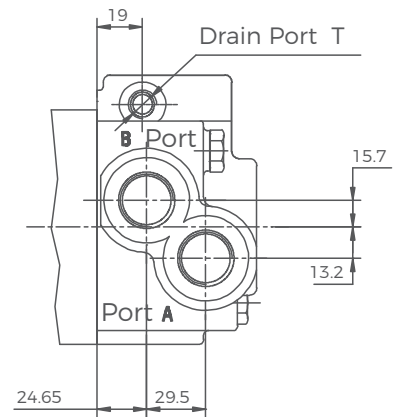

Mounting	U5 (depth)	UK (depth)	MD (depth)	UL (depth)
P(A, B)	1-1/16-12 O-ring	7/8-14 UNF O-ring	M22 x 1.5	2-Ø19.05
T	7/16-20 O-ring	9/16-18 UNF O-ring	M22 x 1.5	7/16-20 UNF
C	—	—	—	3x3/8-16NNC

GKB Bearingless Motor Dimensions and Mountings

Flange HM

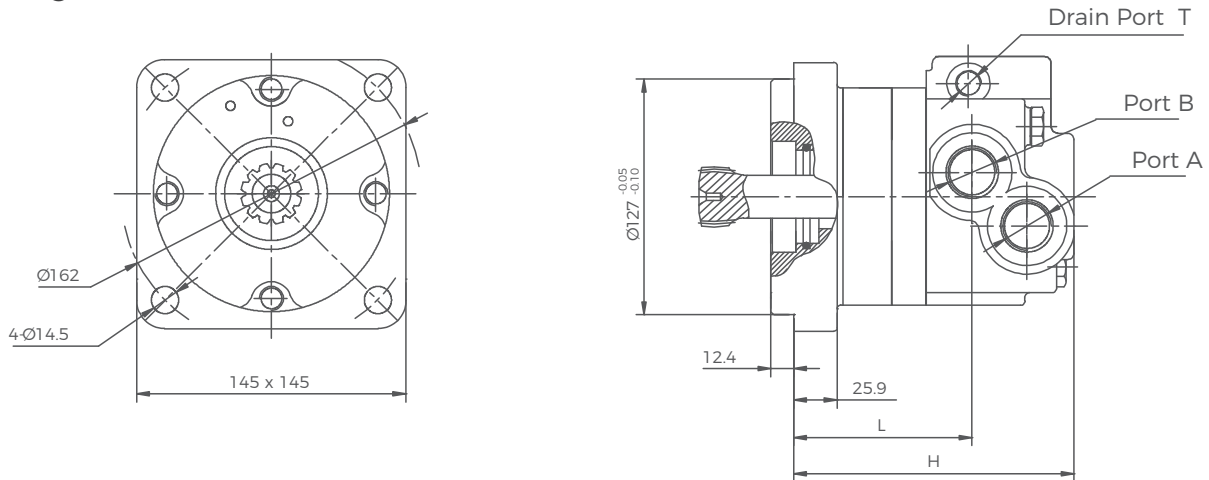

Model	1-1/16-12 or G3/4 Threaded Ports		3/4 Split Flange Oil Ports	
	H	L	H	L
GKB110	146.8	91.0	178.7	99.4
GKB130	150.8	95.1	182.8	103.5
GKB160	157.1	101.4	189.1	109.8
GKB205	165.7	109.9	197.6	118.3
GKB245	157.1	101.4	189.1	109.8
GKB310	165.7	109.9	197.6	118.3
GKB395	176.3	120.6	208.3	129.0
GKB495	189.2	133.5	221.2	141.9
GKB625	206.3	150.5	238.3	159.0

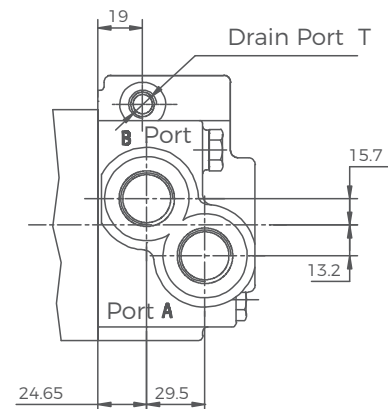

Mounting	U5 (depth)	UK (depth)	MD (depth)	UL (depth)
P(A, B)	1-1/16-12 O-ring	7/8-14 UNF O-ring	M22 x 1.5	2-Ø19.05
T	7/16-20 O-ring	9/16-18 UNF O-ring	M22 x 1.5	7/16-20 UNF
C	—	—	—	3 x 3/8-16UNC



GKB Flange Covers Dimensions

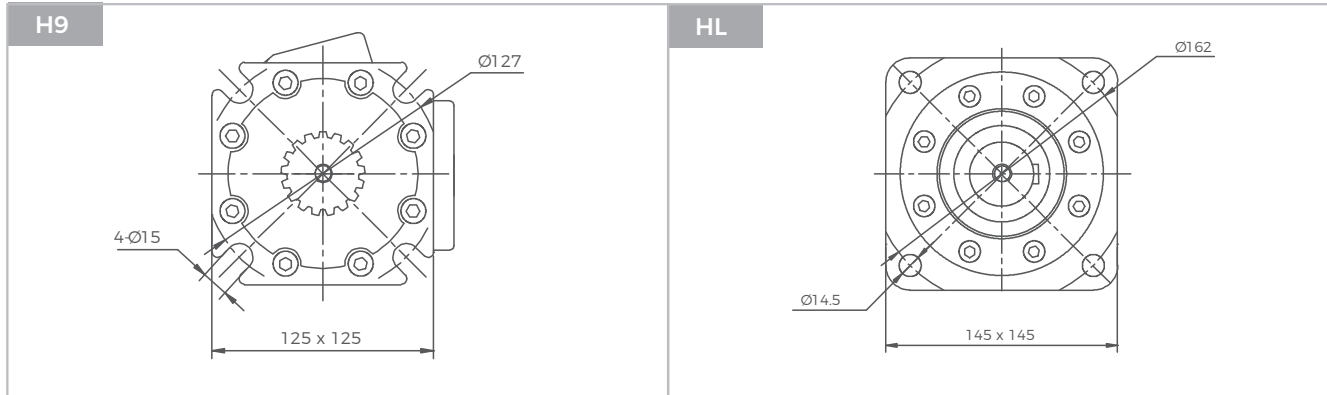

GKB Shafts Dimensions

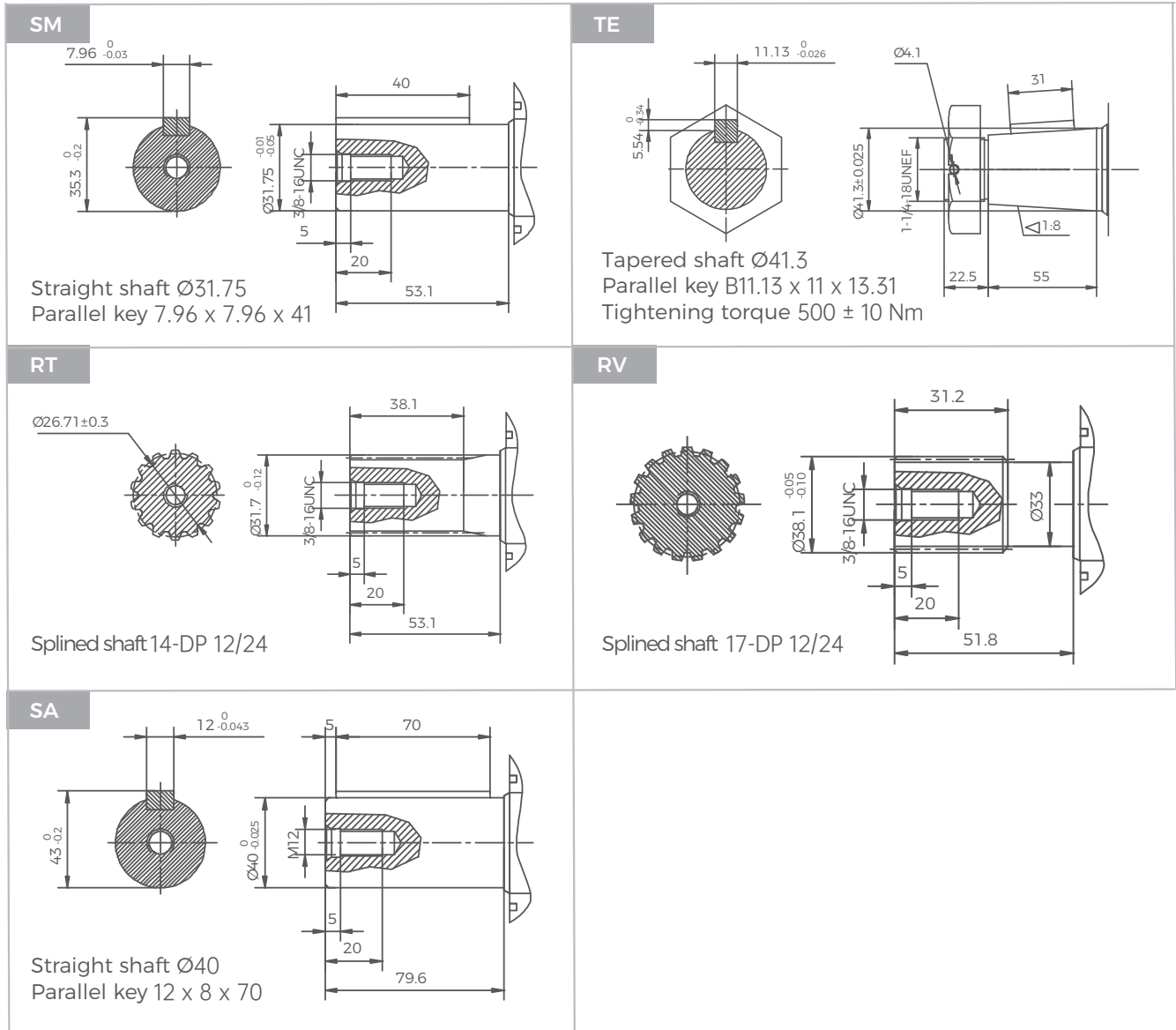

GKB Series Hydraulic Motors

Standard direction of shaft rotation: Standard

When facing shaft end of motor, shaft to rotate:
Clockwise. When port A is pressurized.
Counter-clockwise when port B is pressurized.

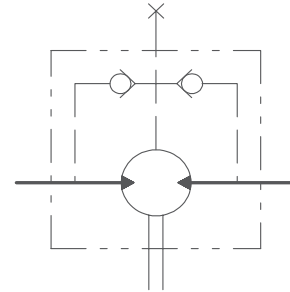
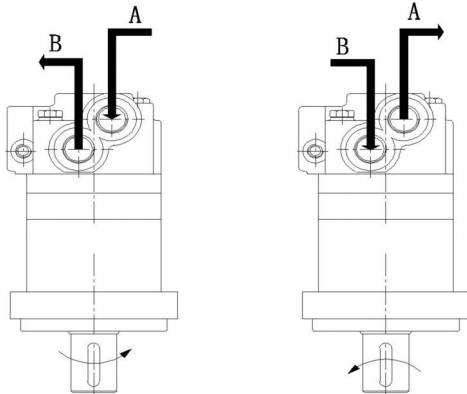

GKB with standard shaft seal check valves and without use of drain connection: The pressure on the shaft seal never exceeds the pressure in the return line.
GKB with standard shaft seal, check valves and with drain connection: The shaft seal

Output shaft axial and radial force

The following curves represent the load capacity at various locations along the radial direction of the motor output shaft. The curves are based on B10 bearing life at rated output torque. (2000 hours or 12,000,000 revolutions at 100RPM). To determine the radial load at speeds other than 100 RPM, multiply the load values on the bearing curves by the factors given in the table below.

RPM	Coefficients
50	1.23
100	1.00
200	0.81
300	0.72
400	0.66
500	0.62
600	0.58
700	0.56
800	0.54

52% increase in load capacity at 3,000,000 rpm or 500 hours.

Wheel motor with tapered shaft

Radial force (daN)

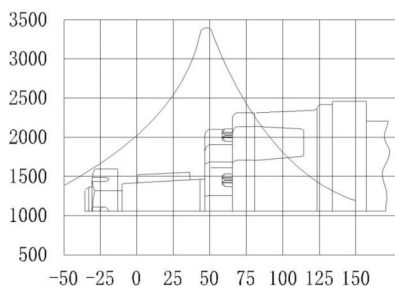

The distance between the force point and the flange surface (mm)

Standard motor with cylindrical shaft

Radial force (daN)

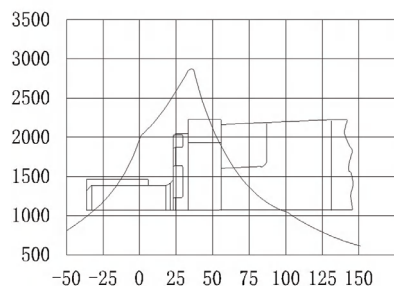

The distance between the force point and the flange surface (mm)

Standard motor with spline shaft

Radial force (daN)

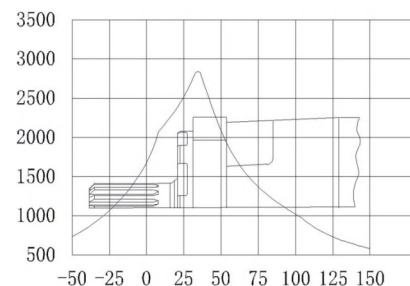

The distance between the force point and the flange surface (mm)

GKC Series Hydraulic Motors

OPTIONS

- Flange connection
- Straight, splined and tapered shaft
- Metric and BSPP ports
- Other special features

APPLICATION

- Conveyors
- Feeding machinery
- Metal working machines
- Textile machines
- Agricultural machines
- Food industries
- Mining machines



General

Max. Displacement	cm ³ /rev [in ³ /rev]	985 [60.0]
Max. Speed	RPM	866
Max. Torque	daNm [lb-in]	cont.:168,5 [14920] int.:187,5 [16580]
Max. Pressure Drop	bar [PSI]	cont.:205 [3000] int.:300 [4500]
Max. Oil Flow	lpm [GPM]	225 [60]
Pressure fluid		Mineral based-HLP (DIN 51524) or HM (ISO 6743/4)
Temperature Range	°C [°F]	-40–140[-104 – 284]
Optimal Viscosity range	mm ² /s [SUS]	20–75[98–347]
Filtration		ISO code 20/16 (Min. recommended fluid filtration of 25 microns)

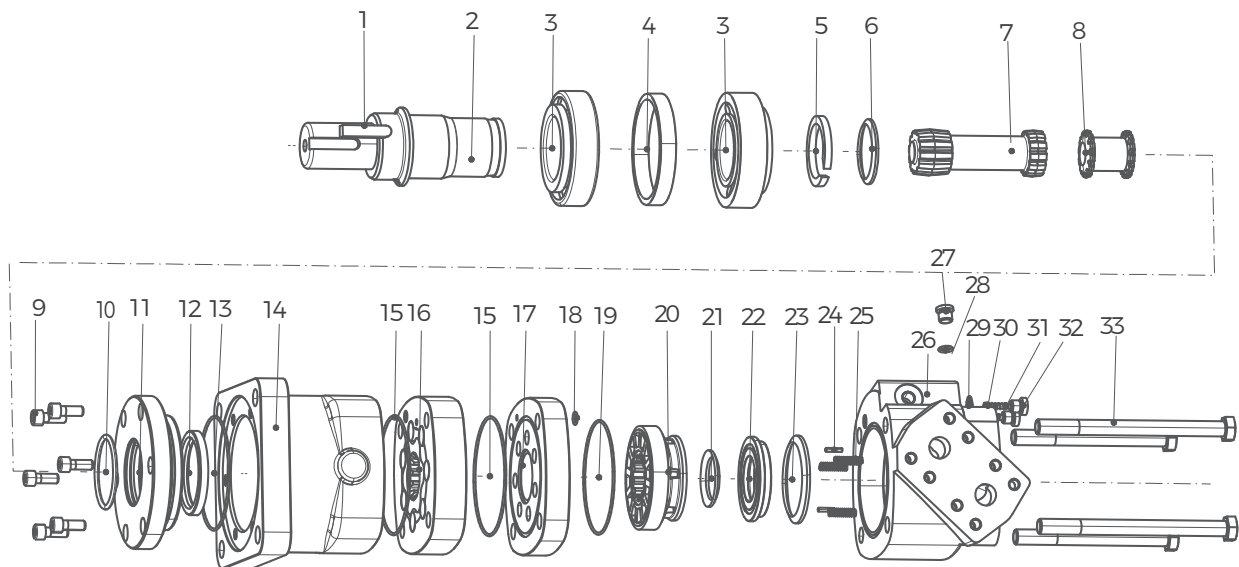

- | | | | | |
|-------------------------------|------------------|-----------------------|-------------------------------|------------------|
| 1 Paralled key | 8 Coupling shaft | 15 O-ring | 22 Distributor pressure plate | 29 Washer |
| 2 Output shaft | 9 Screw | 16 Rotor and stator | 23 Special shape ring | 30 Steel Ball |
| 3 Tapered roller bearing | 10 O-ring | 17 Balance plate | 24 Positioning pins | 31 Spring |
| 4 Bearing outer retainer ring | 11 Front cover | 18 O-ring seal | 25 Spring | 32 Hexagon plugs |
| 5 Washers | 12 Shaft seal | 19 O-ring seal | 26 Rear housing | 33 Screw |
| 6 Special shape ring | 13 O-ring | 20 Distribution plate | 27 Plug | |
| 7 Transmission shaft | 14 Housing | 21 Special shape ring | 28 O-ring | |

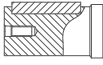
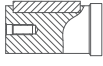
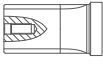
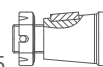

Ordering Code

GKC SERIES		DISP	FLANGE	SHAFT	PORTS	ROTATION	PAINT	FUNCTION
CODE		DISP cm ³ /rev [in ³ /rev]	CODE	FLANGE	CODE	SHAFT	CODE	ROTATION
195		195 [11.9]	CC	4- Ø14.2 square Ø162, pilot Ø 127x13.2 	Y1	Ø35 parallel key 12x12x63 	A	Standard
245		245 [15.0]			G2	Ø38.1 parallel key 9.53x9.53x41.9 	R	Opposite
310		310 [19.0]			FE	Ø38.1 splined tooth 14-DP 12/24 		
390		390 [23.9]			T1	Tapered 1: 8 Ø45 parallel key 11.13x11.13x31.75 		
490		490 [30.0]						
625		625 [38.0]						
735		735 [45.0]						
805		805 [49.0]						
985		985 [60.0]						
							CODE	PORTS
					G3	G3/4, G1/4, manifold 4xM10	A	No paint
					SF5	1-5/16-12UNF O-ring, 7/16-20UNF	B	Blue
					SF7	G1, G1/4	C	Black
							S	Silver grey
							CODE	FUNCTION
							A	Standard
							N	Big radial force
							D	No case drain
							F	Free running
							L	Low speed
							V	High temp.
							S	Low temp.

Specifications

Type		GKC195	GKC245	GKC310	GKC390	GKC490
Displacement cm ³ /rev [in ³ /rev]		195[11.9]	245[15.0]	310[19.0]	390[23.9]	490[30.0]
Max. Speed	Cont.	775	615	485	387	307
RPM	Int.*	866	834	698	570	454
Max. Oil Flow	Cont.	150[40]	150[40]	150[40]	150[40]	150[40]
lpm [GPM]	Int.*	170[45]	210[55]	225[60]	225[60]	225[60]
Max. Torque	Cont.	57,5[5100]	73,5[6510]	93,0[8230]	115,5[10230]	144,5[12800]
daNm [lb - in]	Int.*	86,0[7620]	110,0[9740]	135,5[11990]	163,5[14490]	188,5[16670]
Max. Inter Pressure	Cont.	205[3000]	205[3000]	205[3000]	205[3000]	205[3000]
bar [PSI]	Int.*	310[4500]	310[4500]	310[4500]	310[4500]	275[4000]
	Peak**	310[4500]	310[4500]	310[4500]	310[4500]	310[4500]
Weight, kg [lb]	Standard or Wheel mount	24,9[55.0]	25,2[55.5]	25,6[56.5]	26,3[58.0]	27,0[59.5]
	Bearingless	20,2[44.5]	20,4[45.0]	20,9[46.0]	21,5[47.5]	22,2[49.0]

Type		GKC625	GKC735	GKC805	GKC985
Displacement cm ³ /rev [in ³ /rev]		625[38.0]	735[45.0]	805[49.0]	985[60.0]
Max. Speed	Cont.	241	203	187	153
RPM	Int.*	353	303	280	230
Max. Oil Flow	Cont.	150[40]	150[40]	150[40]	150[40]
lpm [GPM]	Int.*	225[60]	225[60]	225[60]	225[60]
Max. Torque	Cont.	148,0[13100]	1378[12192]	158,2[14004]	168,5[14920]
daNm [lb - in]	Int.*	189,8[16800]	169,9[15040]	185,0[16377]	187,5[16580]
Max. Inter Pressure	Cont.	170[2500]	140[2000]	140[2000]	140[2000]
bar [PSI]	Int.*	221[3200]	170[2500]	170[2500]	140[2000]
	Peak**	240[3500]	205[3000]	170[2500]	170[2500]
Weight, kg [lb]	Standard or Wheel mount	27,9[61.5]	28,6[63.0]	29[64.0]	30,4[67.0]
	Bearingless	23,1[51.0]	23,8[52.5]	24,3[53.5]	25,6[56.5]



GKC Shafts Dimensions

<p>G2</p> <p>Straight shaft $\varnothing 32$ Parallel key 9.525 x 9.525 x 41.9</p>	<p>FE</p> <p>Spline shaft 14-DP 12/24</p>
<p>T1</p> <p>Tapered shaft $\varnothing 45$ Parallel key 11.13 x 11.13 x 31.75 Tightening torque: 500 ± 10 Nm</p>	<p>Y1</p> <p>Straight shaft $\varnothing 35$ Parallel key 12 x 12 x 63</p>

GKC Series Hydraulic Motors

Permissible shaft seal pressure

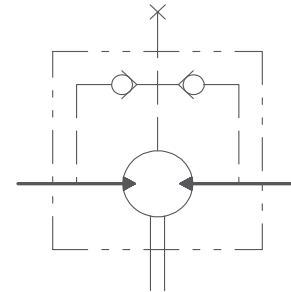
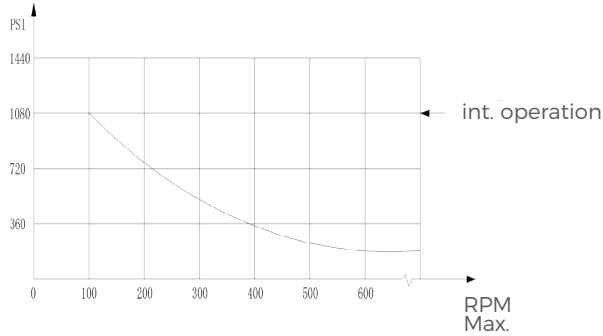

GKC with standard shaft seal check valves and without use of drain connection: The pressure on the shaft seal never exceeds the pressure in the return line.

GKC with standard shaft seal, check valves and with drain connection: The shaft seal pressure equals the pressure on the drain line.

Drain Port

In applications without a motor drain line, the pressure exerted on the shaft seal is marginally in excess of the return line pressure. When the Drain line is used, the pressure exerted on the shaft seal is equal to the return line pressure.

Standard direction of shaft rotation: Standard

When facing the shaft end of the motor, the shaft rotates: clockwise when port "A" is pressurized. When port "B" is pressurized, it rotates counterclockwise.

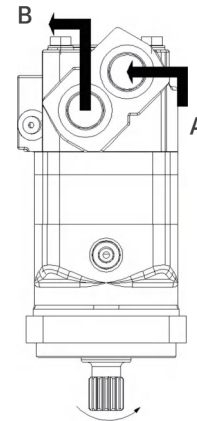

GKC for CC Mounting Radial forces

Radial forces-(daN)

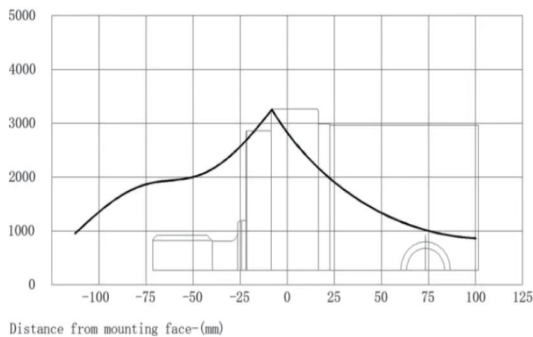

The bearing curve represents allowable bearing loads for an B10 bearing life(2000 hours or 12×10^6 revolutions at 100rpm) at rated output torque. Other speed load multiply a load values. The maximum load curve is defined by bearing static load capacity. This curve should not be exceeded at any time including shock loads.

GKS Series Hydraulic Motors

Options

- Flange connection
- Motor with needle roller bearing
- Shaft seal for high and low pressure
- Straight, splined and tapered shafts
- Metric and BSPP ports
- Other special features

Applications

- Harvesters
- Augers
- Sprayers
- Grinders and Mixers
- Horizontal/Vertical Drilling
- Material Handling



General

Single-Speed		
Max.Displacement	cm ³ /rev [in ³ /rev]	677 [41.3]
Max.Speed	RPM	cont.:495 int.:770
Max.Torque	daNm [lb-in]	cont.:2,469 [21,856] int.:2,893 [25,602]
Max.Pressure Drop	bar [PSI]	cont.:310 [4,500] int.:345 [5,000] peak:379 [5,500]
Max.Oil Flow	lpm [GPM]	cont.:170 [45] int.:265 [70]
Temperature Range	°C [°F]	MAX 82°C [180°F]
Optimal Viscosity range	mm ² /s [SUS]	Premium quality, anti-wear type hydraulic oil with a viscosity of not less than 13 cSt [70 SUS] at operating temperature.
Filtration		Per ISO Cleanliness Code, 4406: 20/18/13.

General

Two Speed		
Max.Displacement	cm ³ /rev [in ³ /rev]	677 [41.3]
	RPM	High Speed Mode:743
Max.Speed		Low Speed Mode:495
Max.Torque	daNm [lb-in]	High Speed Mode
		cont.:1,646 [14,571] int.:1,929 [17,068]
		Low Speed Mode
		cont.:2,469 [21,856] int.:2,893 [25,602]
Max.Pressure Drop	bar [PSI]	cont.:310 [4,500] int.:345 [5,000] peak:379 [5,500]
Max.Oil Flow	lpm [GPM]	170 [45]
Temperature Range	°C [°F]	MAX 82°C [180°F]
Optimal Viscosity range	mm ² /s [SUS]	Premium quality, anti-wear type hydraulic oil with a viscosity of not less than 13 cSt [70 SUS] at operating temperature.
Filtration		Per ISO Cleanliness Code, 4406: 20/18/13.

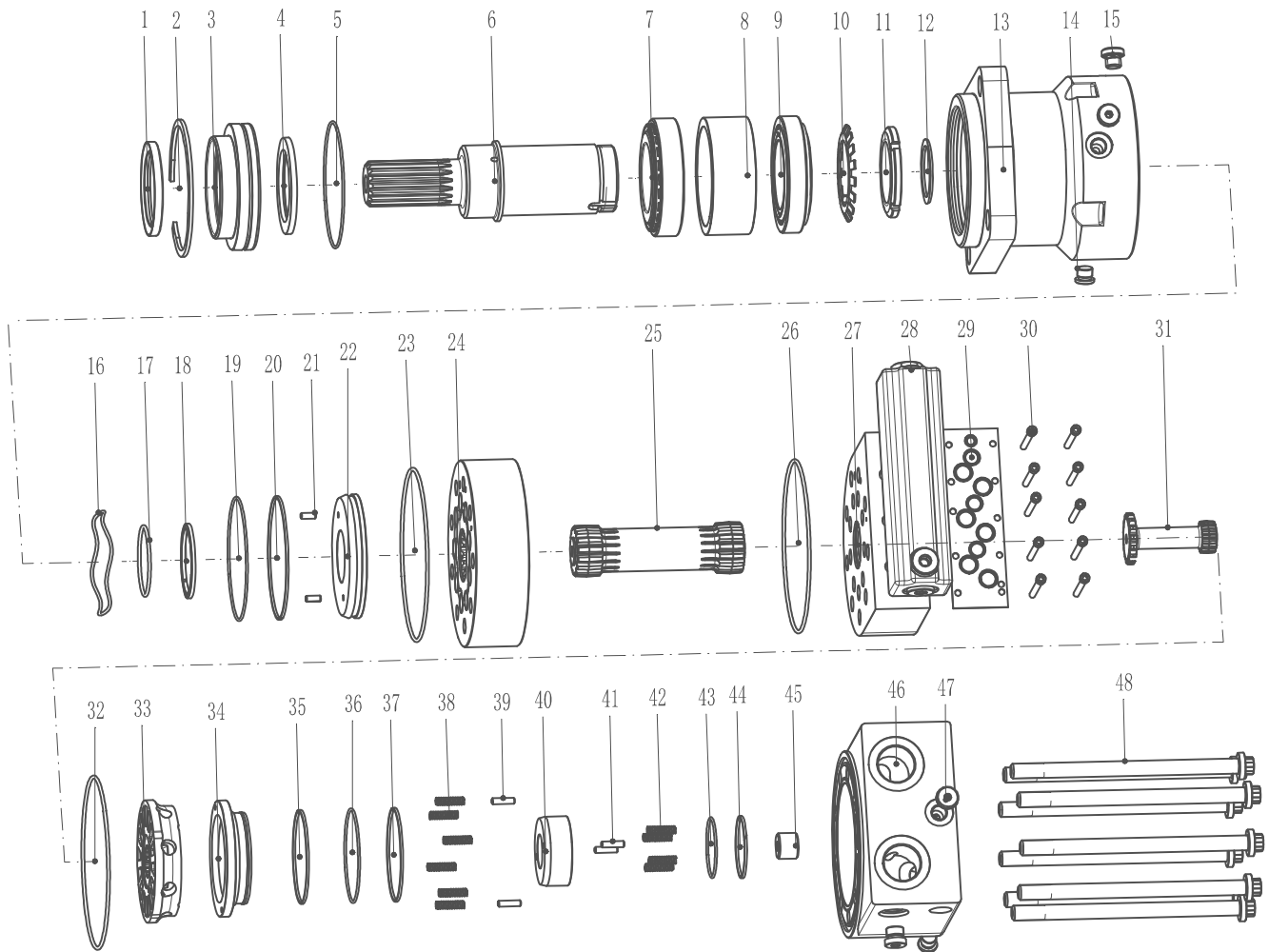

- | | | | |
|--------------------------|----------------------------|--------------------------------|------------------------------|
| 1 Dust seal | 13 Front housing | 25 Transmission shaft | 37 Spacer |
| 2 Hole retaining ring | 14 1/2-20UNF Plug | 26 O-ring | 38 Spring |
| 3 Bearing cover | 15 G1/4 Plug | 27 Balancing disc | 39 Spring cylindrical pin |
| 4 Shaft seal | 16 Wave spring | 28 Two speed motor manifold | 40 Rear housing pressing cap |
| 5 O-ring | 17 O-ring | 29 Manifold partition assembly | 41 Spring cylindrical pin |
| 6 Output shaft | 18 Dottle pin | 30 Bolt 3/16-32UNF | 42 Spring |
| 7 Tapered roller bearing | 19 O-ring | 31 Drive shaft | 43 O-ring |
| 8 Bearing spacer | 20 Spacer | 32 O-ring | 44 Spacer |
| 9 Tapered roller bearing | 21 Elastic cylindrical pin | 33 Valve Plate | 45 Washer |
| 10 Lock washer | 22 Piston | 34 Rear Housing Pressure Ring | 46 Rear housing |
| 11 Lock nut | 23 O-ring | 35 Spacer Sleeve | 47 9/16-18UNF plug |
| 12 Dottle pin | 24 Rotor and stator | 36 O-Ring | 48 Bolt |

Ordering Code

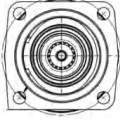
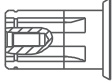
GKS SERIES		DISP	FLANGE		SHAFT	PORTS	ROTATION	PAINT	FUNCTION	
CODE	DISP cm ³ /rev [in ³ /rev]	CODE	FLANGE	CODE	SHAFT	CODE	ROTATION	CODE	FUNCTION	
344	343.8 [20.98]	SA	Standard, 4 bolt: 127.00 pilot dia. 17.02 dia. Bolt circle dia. 161.92 	A1	Splined shaft 17 DP 12/24 M12 	U1 1-1/16-12 UN-2B 9/16-18 UNF-2B	A	No paint Blue Black Silver grey	A	Standard
400	400.0 [24.40]			R			Opposite			
434	434.2 [26.50]			U5	G1 (BSP) O-ring G1/4 (BSP) O-ring	C	Black			
480	479.5 [29.26]			N	Big radial force	S	Silver grey			
677	677.3 [41.33]			F	Free running	L	Low speed			
		V	High temp.	S	Low temp.					

GWD Series Hydraulic Motors

Options

- Rotor flow distribution, geroler type
- Geroler type
- Motor with needle bearing
- Align the ports on the side
- Straight, splined and tapered shafts
- High pressure seal
- Metric, SAE and BSPP ports

Applications

- Aerial work platform
- Material handling and lifting machines
- Agricultural machines
- Marine machines
- Road machines
- Garden machines
- Lawn and turf machines



General



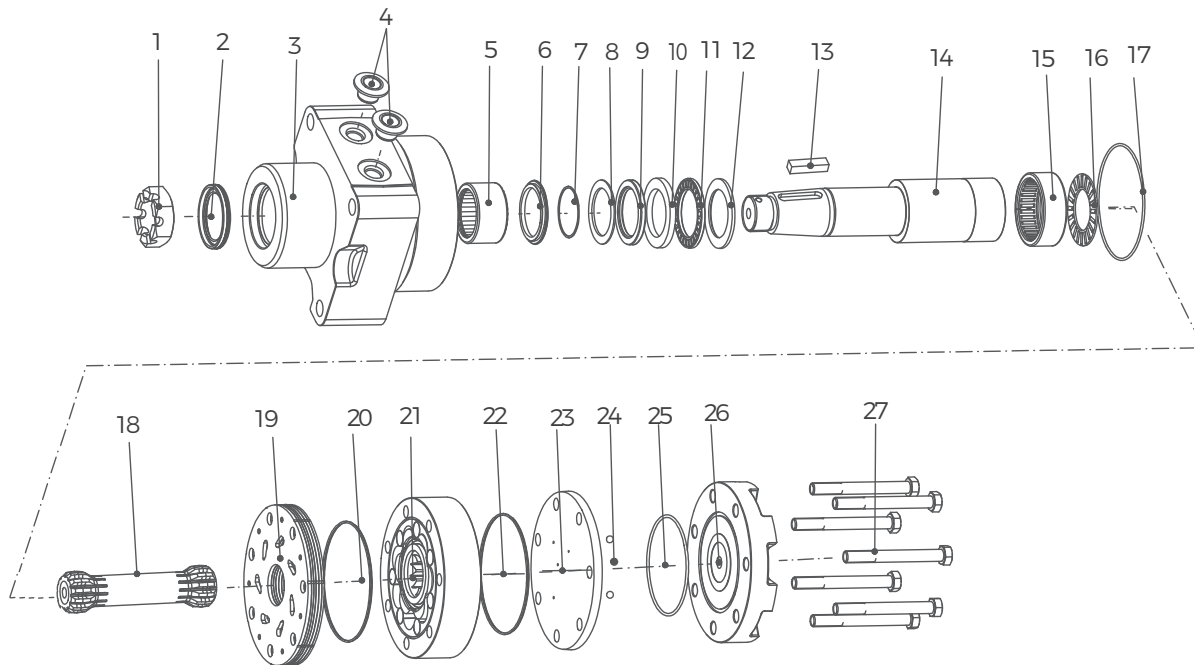









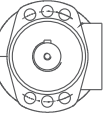

Max. Displacement	cm ³ /rev [in ³ /rev]	748[45.6]
Max. Speed	RPM	490
Max. Torque	daNm [lb-in]	cont.: 106,2[9400] int.: 123,7[10950]
Max. Pressure Drop	bar [PSI]	cont.: 207 [3000] int.: 241 [3500]
Max. Oil Flow	lpm [GPM]	95 [25.1]
Pressure fluid		Mineral based- HLP (DIN 51524) or HM (ISO 6743/4)
Temperature Range	°C [°F]	-40-140 [-104-284]
Optimal Viscosity range	mm ² /s [SUS]	20-75 [98-347]
Filtration		ISO code 20/16 (Min. recommended fluid filtration of 25 microns)



- | | | | | |
|-----------------------|----------------------|-------------------------------|-----------------------|---------------|
| 1 Castle nut | 7 O-ring | 13 Flat key | 19 Distribution plate | 26 Rear cover |
| 2 Shaft seal | 8 Washer | 14 Output shaft | 20 Special shape ring | 27 Screw |
| 3 Housing | 9 shaft seal | 15 Rear needle roller bearing | 22 Special shape ring | |
| 4.Port Plug | 10.Bearing Stop Ring | 16.Plane Bearing | 23.Balance Disk | |
| 5.Thrust Ball Bearing | 11.Plane Bearing | 17.O-Ring | 24.Steel Ball | |
| 6.Bearing Pedestal | 12.Bearing Stop Ring | 18.Transmission Shaft | 25.O-Ring | |



Ordering Code

CWD SERIES		DISP	FLANGE	SHAFT	PORTS	ROTATION	PAINT	FUNCTION		
CODE	DISP cm ³ /rev	CODE	FLANGE	CODE	SHAFT	CODE	ROTATION	CODE	FUNCTION	
120	121	W4	Wheel Ø147.6 front pilot 4- Ø13.1 rear pilot Ø127×3 	SH	Ø35 parallel key 10×8×45 	A	Standard	CODE	PAINT	
160	162		W5	Wheel Ø147.6 front pilot 4- Ø13.1 rear pilot Ø127×6 	SL	Ø38 parallel key 9.5×9.5×38.1 	B			Blue
200	204			A9	6- Ø13.5 SAE Ø106.4 pilot Ø82.5×3 	TB	Tapered Ø35 1:10 parallel key 7.96×7×31.5 Nut Fastening Torque: 325 Nm 			C
230	232	W6			Ø106.4 wheel 4- Ø13.5 pilot Ø82.5×5 	TA	Tapered Ø38.1 1:8 parallel key 7.96×7×36.5 Nut Fastening Torque: 415-540 Nm 	S	Silver grey	
260	261		T2	Ø106.4 wheel 4- Ø13.5 pilot Ø82.5×5 	RQ	Ø25.3 Splined 6-25.3×21×6.2 	CODE			FUNCTION
300	300	UD			Ø106.4 wheel 4- Ø13.5 pilot Ø82.5×5 	CODE			PORTS	A
350	348		UF	Ø106.4 wheel 4- Ø13.5 pilot Ø82.5×5 		CODE			PORTS	N
375	363	GC			Ø106.4 wheel 4- Ø13.5 pilot Ø82.5×5 	CODE			PORTS	D
470	465		MC	Ø106.4 wheel 4- Ø13.5 pilot Ø82.5×5 		CODE			PORTS	F
540	536	CODE			PORTS	UD	9/16-18UNF	L	Low speed	
620	631	CODE			PORTS	UF	7/8-14UNF	V	High temp.	
750	748	CODE			PORTS	GC	G1/2	S	Low temp.	
			CODE			PORTS	MC	M22×1.5		



Specifications

Type		GWD120	GWD160	GWD200	GWD230	GWD260	GWD300
Disp. cm ³ /rev.		121	162	204	232	261	300
Max. Speed	Cont	360	370	300	260	260	250
RPM	Int.	490	470	370	320	350	320
Max. Flow	Cont	45	61	68	68	76	83
LPM	Int.	61	76	83	83	91	95
Max. Torque	Cont	327	475	542	611	712	825
Nm	Int.	383	542	633	712	791	938
Max. Pressure Drop	Cont	207	207	207	207	207	207
bar	Int.	241	241	241	241	241	241
	Peak	276	276	276	276	276	276
Max. No-load Pressure		8	10	10	10	10	10
bar							
Min Operating Nm	Drop Cont	235	342	390	440	513	513
Torque At Max. Pres.	Drop Int.	280	396	462	520	577	577
Weight kg	GWD	13.3	13.3	13.7	13.8	14.1	14.1

Type		GWD350	GWD375	GWD470	GWD540	GWD620	GWD750
Disp. cm ³ /rev.		348	363	465	536	631	748
Max. Speed	Cont	220	200	160	140	120	100
RPM	Int.	270	250	200	170	150	130
Max. Flow	Cont	76	76	76	76	76	76
LPM	Int.	95	91	91	91	91	91
Max. Torque	Cont	921	1006	1096	983	1014	1062
Nm	Int.	1045	1158	1184	1243	1291	1237
Max. Pressure Drop	Cont	207	207	172	138	121	103
bar	Int.	241	241	189	173	155	121
	Peak	276	276	207	207	173	138
Max. No-load Pressure		10	10	10	12	12	12
bar							
Min Operating Nm	Drop Cont	663	724	822	737	761	797
Torque At Max. Pres.	Drop Int.	763	845	900	945	981	940
Weight kg	GWD	15.5	15	15.5	16.1	16.8	17.5

GWD Dimensions and Mountings

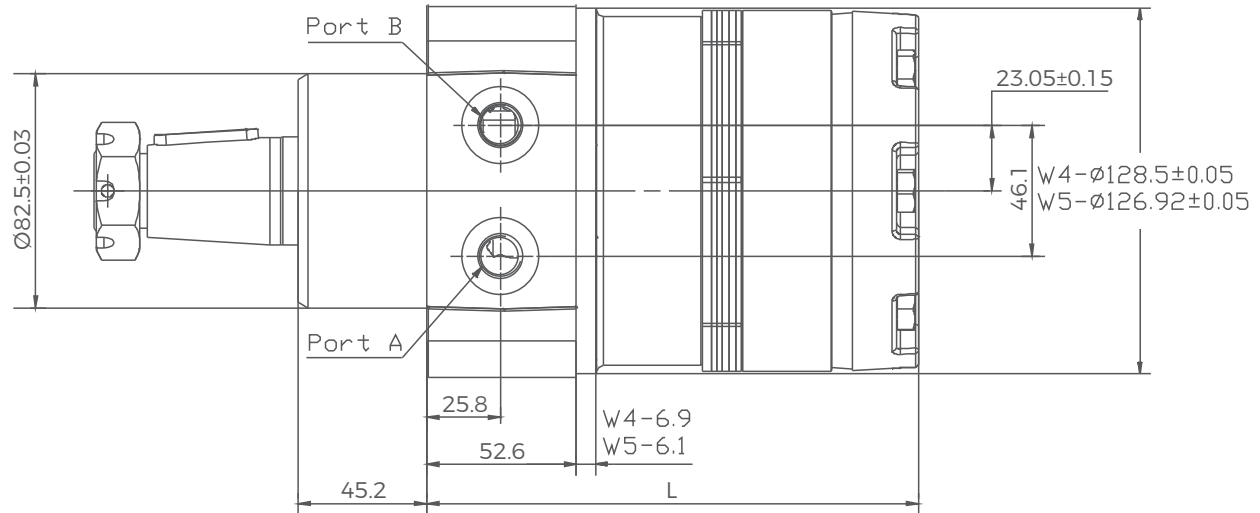

Model	L	Weight
	mm	kg
GWD120	156	13.3
GWD160	156	13.3
GWD200	159	13.7
GWD230	162	13.8
GWD260	165	14.1
GWD300	168	14.4
GWD350	172	15.5
GWD375	174	15.0
GWD470	182	15.5
GWD540	188	16.1
GWD620	196	16.8
GWD750	206	17.5

GWD with Brake Dimensions and Mountings

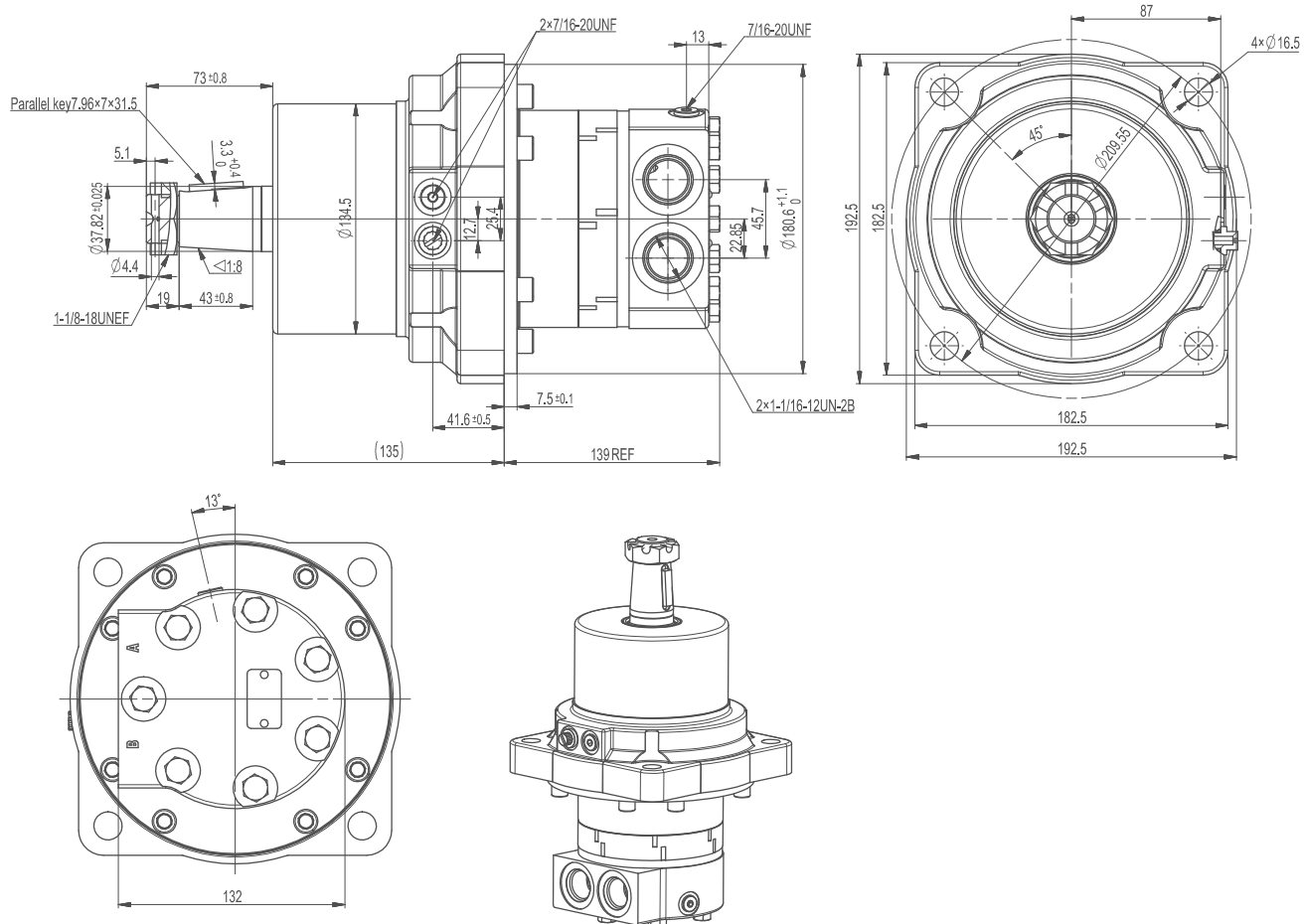

DISPLACEMENT	540cm ³ /rev
MAX.CONTINUOUS RATING PRESSURE	20.5MPa
RATED BRAKE TORQUE	2600Nm
THE BRAKE RELEASE PRESSURE	4MPa, Max.
RELEASE PRESSURE	20.7MPa, Max.
WORKING TEMPERATURE	82 °C
Brake Spring Quantity	25
PAINT	BLACK



CWD Flange Covers Dimensions

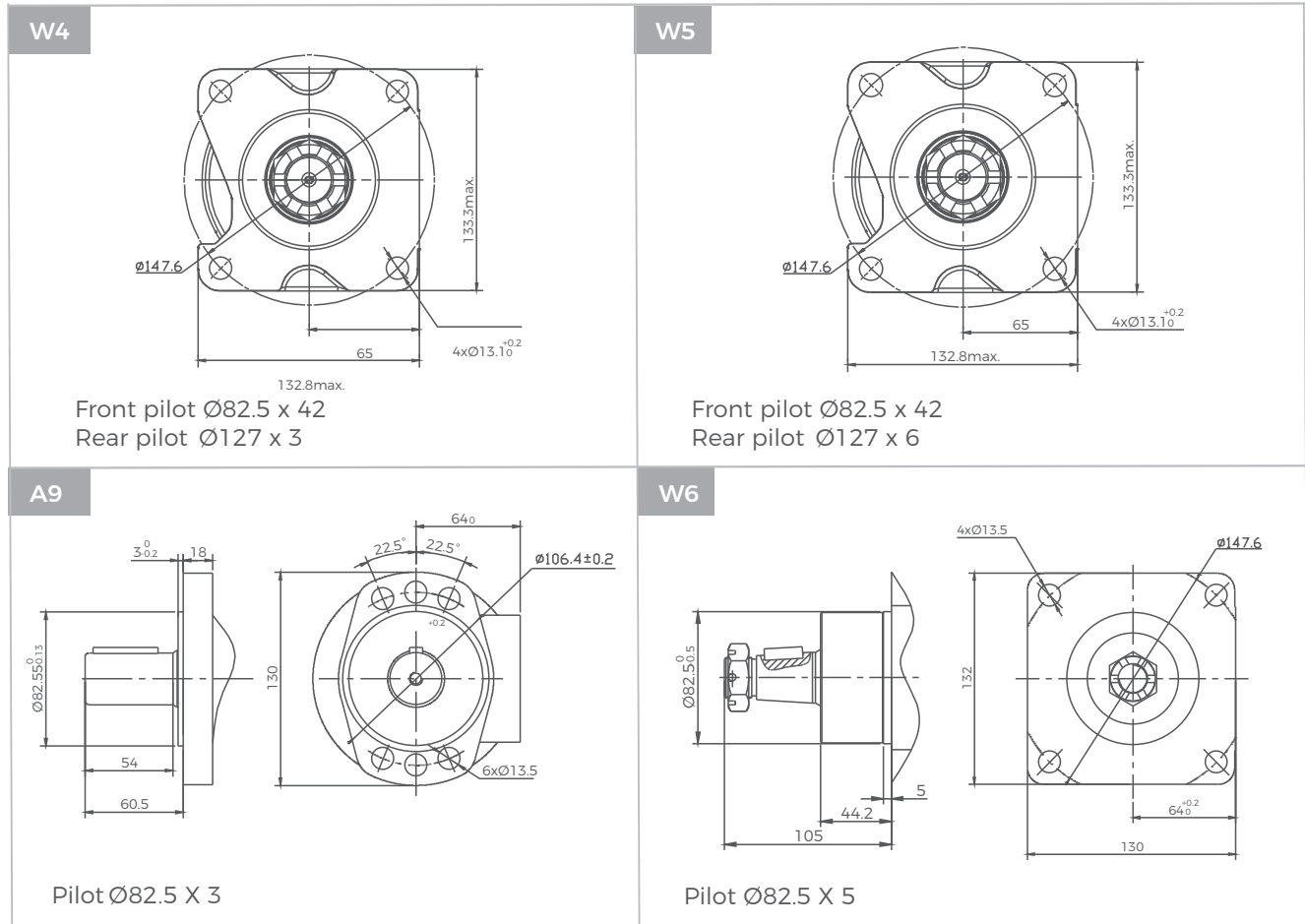

GWD Shafts Dimensions

<p>TB</p> <p>Tapered shaft Ø35 Parallel key 7.96 x 7 x 31.5 Tightening torque: 325 Nm</p>	<p>TA</p> <p>Tapered shaft Ø38.1 Parallel key 7.96 x 7 x 36.5 Tightening torque: 410-540 Nm</p>
<p>SL</p> <p>Straight shaft Ø38.1 Parallel key 9.5 x 9.5 x 38.1</p>	<p>SH</p> <p>Straight shaft Ø35 Parallel key 10 x 8 x 45</p>
<p>T2</p> <p>Tapered shaft Ø31.75 Parallel key 7.96 x 7.96 x 25.4 Tightening torque: 200 ± 10 Nm</p>	<p>RQ</p> <p>Splined shaft 6-25.3 x 21 x 6.2</p>

GWD Series Hydraulic Motors

Shaft Rotation Direction: Standard

When looking at the shaft end of motor, shaft will rotate:

-Clockwise.

When port B is pressurized.

-Counter-clockwise when port A is pressurized.

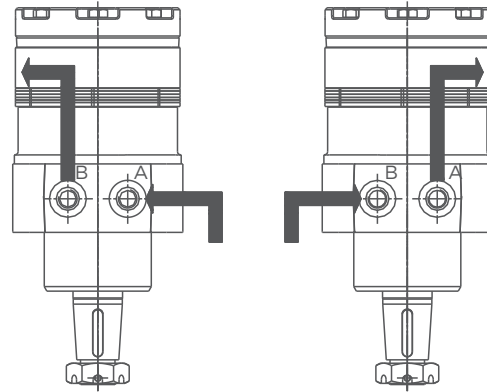
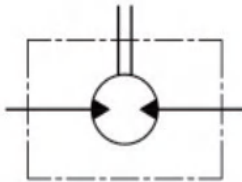

W4 & W5 Wheel Mounts

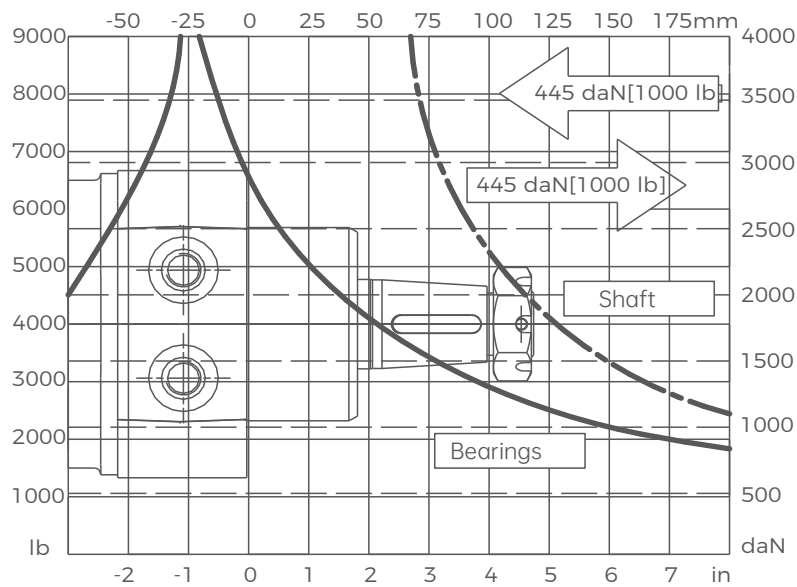

GWH Series Hydraulic Motors

Options

- Flange connection
- Motor with needle roller bearing
- Shaft seal for high and low pressure
- Straight, splined and tapered shafts
- Metric and BSPP ports
- Other special features

Applications

- Agricultural Equipment
- Utility & Off-Road Vehicles
- Material Handling machines
- Forklifts
- Street sweepers
- Mining machines



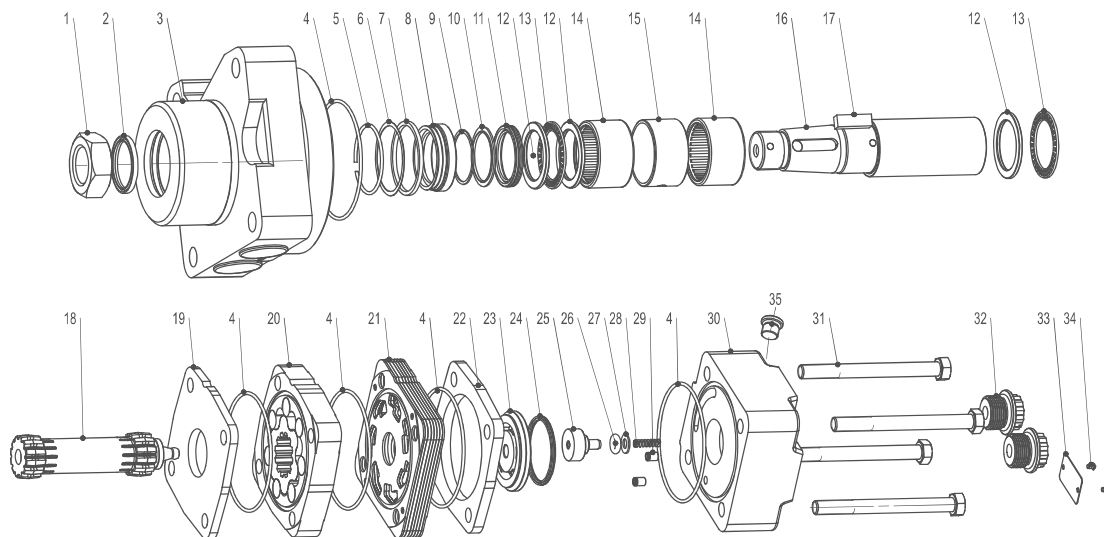

General

Max.Displacement	cm ³ /rev [in ³ /rev]	409[24.9]
Max.Speed	RPM	830
Max.Torque	daNm [lb-in]	cont:946[8400] int:1019[9050]
Max.Pressure Drop	bar [PSI]	cont:207[3000] int:276[4000]
Max.Oil Flow	lpm [GPM]	95[25]
Min. Speed	[RPM]	5
Pressure fluid		Mineral based- HLP (DIN 51524) or HM (ISO 6743/4)
Temperature Range	°C [°F]	-40-140[-104-284]
Optimal Viscosity range	mm ² /s [SUS]	20-75[98-347]
Filtration		ISO code 20/16 (Min.recommended fluid filtration of 25 microns)



- | | | | |
|-------------------------------|--|---------------------------------|--------------------------------|
| 1. Hexagon Nut | 11. Shaft Seal | 19. Partition Plate | 28. spring |
| 2. Dust Seal | 12. Thrust Washer | 20. Rotor Subassembly | 29. Check Valve |
| 3. Housing | 13. Plain Bearing | 21. Welded Valve Plate Assembly | 30. Rear Cover |
| 4. O-Ring | 14. Needle Roller Bearing
with Retainer | 22. Spacer Sleeve | 31. Hexagon Head Bolt |
| 5. Wire Spring Retaining Ring | 15. Spacer Ring | 23. Valve Plate | 32. Oil Port Cap (with O-Ring) |
| 6. Gasket | 16. Output shaft | 24. Seal Ring | 33. Nameplate |
| 7. Rectangular Seal | 17. Square Key | 25. Brake Pad Assembly | 34. Nameplate Rivet |
| 8. Combined Oil Seal Bracket | 18. Drive Shaft | 26. O-Ring | 35. O-Joint |
| 9. Shaft Seal Retainer | | 27. Quad-Ring Retainer | |

Ordering Code

GWH SERIES		DISP	FLANGE		SHAFT	PORTS	ROTATION	PAINT	FUNCTION	
CODE	DISP	CODE	FLANGE	CODE	SHAFT	CODE	ROTATION	CODE	FUNCTION	
	cm ³ /rev [in ³ /rev]									
50	52 [3.2]	W9	Wheel Ø147.62 4-Ø13.1 Front pilot Ø82.5x41 Rear pilot Ø126.92x5 	TC	Tapered Ø31.75 Parallel key 7.96 x7 x 24 	A	Standard	A	No paint	
80	76 [4.6]		W10							Wheel Ø147.62 4-Ø13.1 Front pilot Ø82.5x45.2 Rear pilot Ø126.92x5 
90	89 [5.4]			R	Opposite	C	Black	D	No case drain	
110	111 [6.8]									S
125	127 [7.7]	S		Silver grey	S	Low temp.	V	High temp.	S	
160	164 [10.0]		S							Silver grey
200	205 [12.5]	S		Silver grey	S	Low temp.	S	Low temp.	S	
250	254 [15.5]		S							Silver grey
300	293 [17.9]	S		Silver grey	S	Low temp.	S	Low temp.	S	
400	409 [24.9]		S							Silver grey



GWH Specifications

Type		GWH050	GWH080	GWH090	GWH110	GWH125
Displacement cm ³ /rev [in ³ /rev]		52[3.2]	76[4.6]	89[5.4]	111[6.8]	127[7.7]
Max. Speed, [RPM]	Cont.	680	800	680	680	580
	Int.	830	950	840	850	740
Max. Torque daNm [lb-in]	Cont.	135[1200]	191[1700]	225[2000]	298[2650]	338[3000]
	Int.	158[1400]	222[1975]	270[2400]	349[3100]	394[3500]
Max. Pressure Drop Cont. Drop bar [PSI]	cont.	207[3000]	207[3000]	207[3000]	207[3000]	207[3000]
	int.	242[3500]	242[3500]	242[3500]	242[3500]	242[3500]
	Peak**	276[4000]	276[4000]	276[4000]	276[4000]	276[4000]
Max. Oil Flow lpm [GPM]	Cont.	38 [10]	53[14]	61 [16]	76 [20]	76 [20]
	int.	45[12]	64[17]	76[20]	95 [25]	95[25]

Type		GWH050	GWH080	GWH090	GWH110	GWH125
Displacement cm ³ /rev [in ³ /rev]		164[10.0]	205[12.5]	254[15.5]	293[17.9]	409[24.9]
Max. Speed, [RPM]	Cont.	460	370	290	250	180
	Int.	580	460	370	320	230
Max. Torque daNm [lb-in]	Cont.	44[3975]	569[5050]	704[6250]	811[7200]	946[8400]
	Int.	512[4550]	653[5800]	799[7100]	929[8250]	1019[9050]
Max. Pressure Drop Cont. Drop bar [PSI]	cont.	207[3000]	207[3000]	207[3000]	207[3000]	173[2500]
	int.	242[3500]	242[3500]	242[3500]	242[3500]	189[2750]
	Peak**	276[4000]	276[4000]	276[4000]	276[4000]	207[3000]
Max. Oil Flow lpm [GPM]	Cont.	76[20]	76 [20]	76 [20]	76 [20]	76 [20]
	int.	95[25]	95 [25]	95[25]	95[25]	95[25]

GBD Series Hydraulic Motor Brakes

Options

- Double heavy-duty roller bearings
- Double release ports
- Wet braking, spring loaded
- Smaller axial installation size
- Low noise, long service life

Applications

- Aerial work platform
- Wheel drive
- Swing drive
- Transmission



General

Specifications		GBD10	GBD15
Min. static torque	Nm	1150	1500
Brake release pressure	MPa	2.8	2.8
Max. release pressure	MPa	27.6	27.6
Min. oil released by brake	cm ³	11.5	11.5
Max. speed	rpm	250	250
Brake chamber oil volume	cm ³	100-120	100-120
Max. working oil temperature	°C	82	82
Weight	Kg	18	20

GBD Dimensions and Mountings

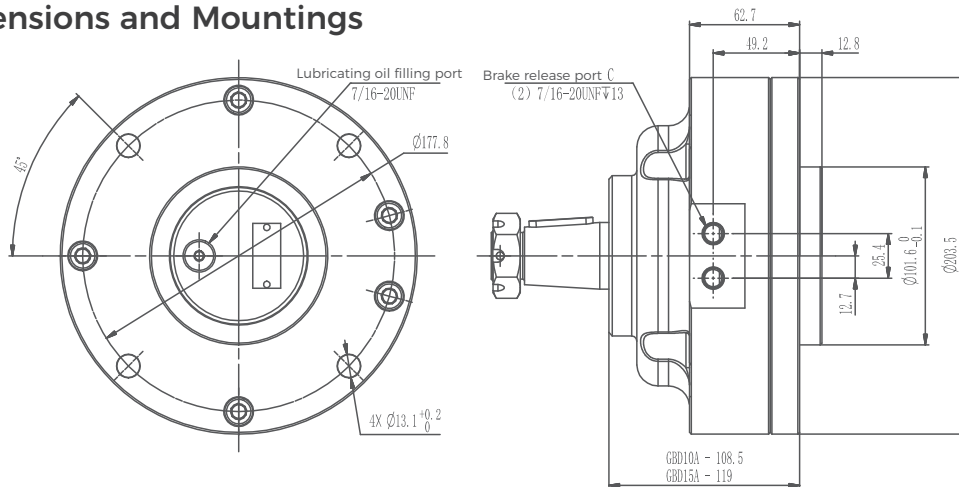

GBD Shaft Dimension

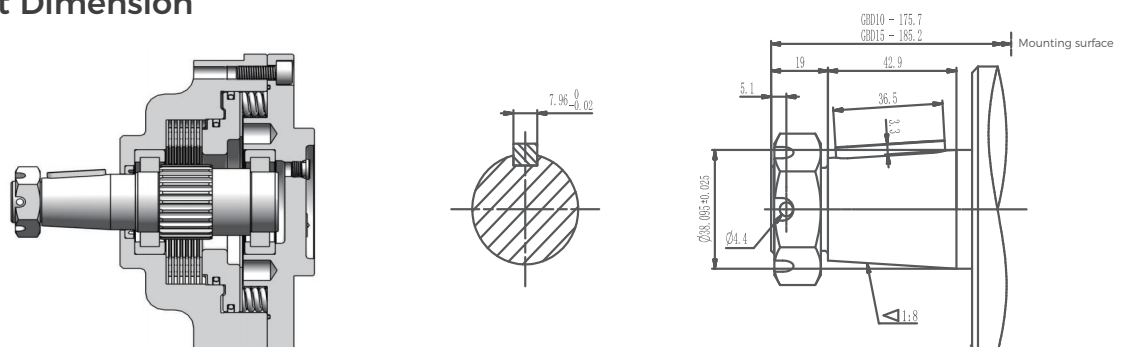

Ordering Code

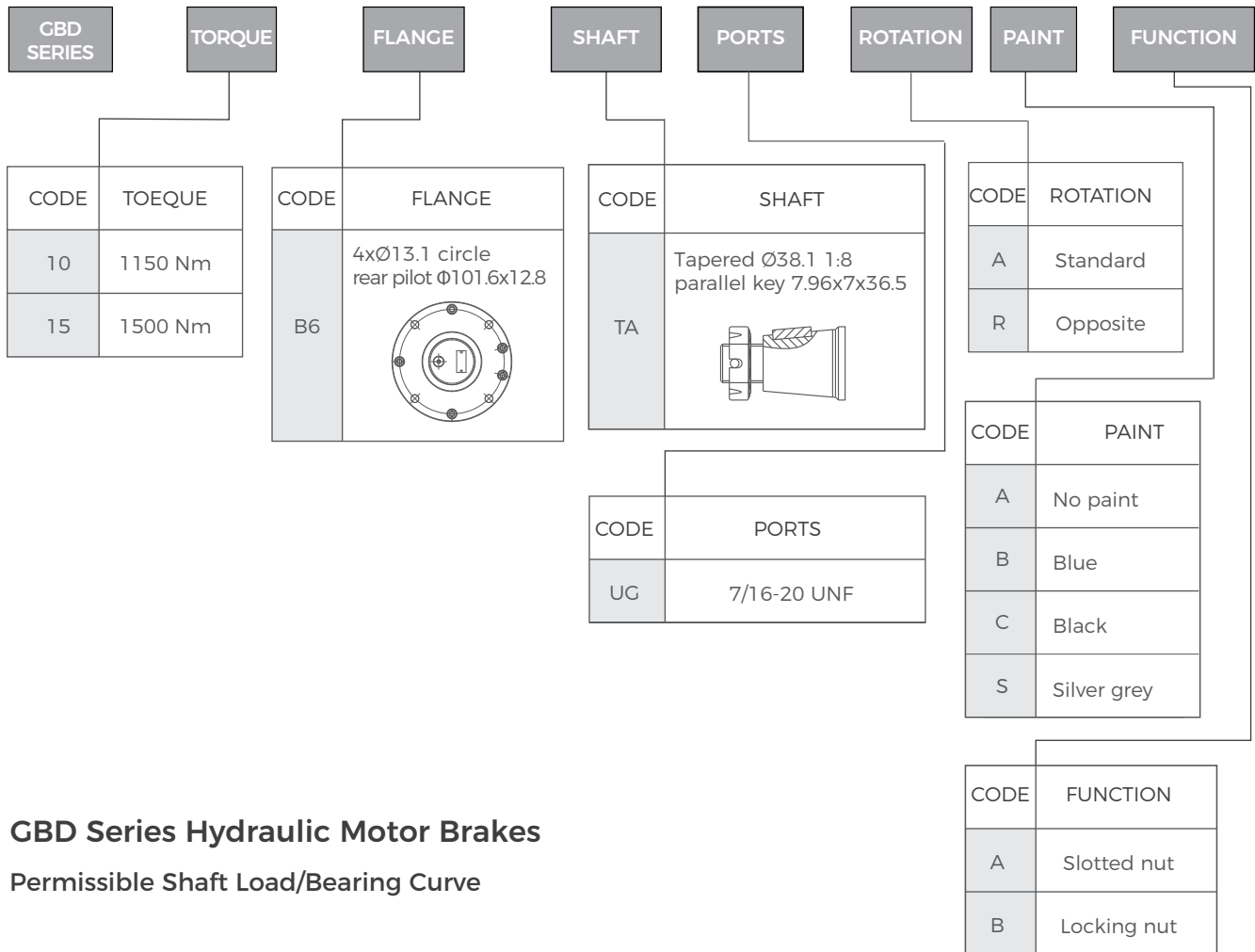

GBD Series Hydraulic Motor Brakes

Permissible Shaft Load/Bearing Curve

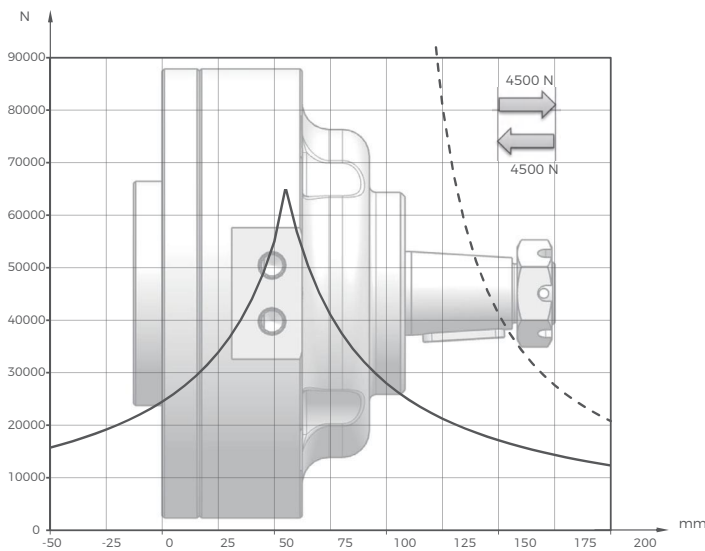

As shown in the figure, when the axial load is 0N, the radial allowable load of the output shaft is related to the distance between the mounting surface of the flange and the point where the load is applied. The solid line shows the allowable bearing radial load. Denotes the use of hydraulic oil containing anti-wear additives, and the curve is established on the basis of continuous output torque cut, motor speed of 100rpm, bearing L10 service life of 2000 hours. The dashed line shows the maximum radial load on the shaft. If the shaft extension load exceeds this value, the motor will be damaged.