

Technical Information

Load Sensing Proportional Valves

GBV60 / GBV80 / GBV100 / GBV200

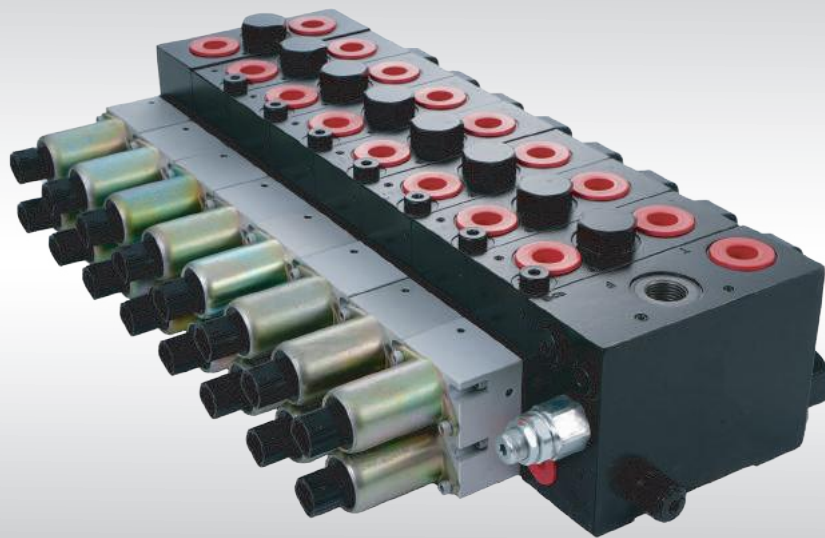



GUORUI HYDRAULICS

Innovation Leads the Future

GRH try our best to create more value for you with products and service

Guorui Hydraulics

About GRH

GRH was established in 1986, focusing on providing customers with quality hydraulic components and solutions to hydraulic system in the applications of engineering machinery, mobile industries, agricultural machinery, aviation, mining, and other fields. Main products include gear pump, gear motor, flow divider, orbital motor, load sensing proportional valve, monoblock valve, sectional valve, manifold assembly and hydraulic power unit as well.

Long-term Development Strategy

Reducing emissions by new energy is one of GRH's long-term strategies. GRH will be providing innovative technologies, products and services for the global development of new energy, moving towards a century development strategy, and writing a century-new chapter in the hydraulic field.





Innovation Leads the Future

Through a few decades of development, GRH has built an intelligent manufacturing factory, gathering international R&D talents, accumulating rich R&D and manufacturing experience, possessing independent intellectual property rights, continuously providing customers with new products and technologies, and creating value for all of the customers.

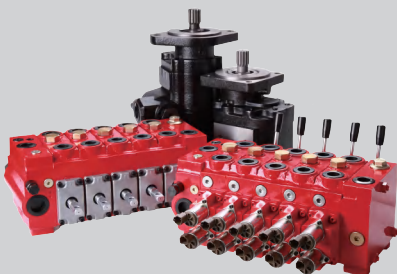

Proportional Control Valves

	04-14	└ GBV60 Proportional Control Valves
GBV80 Proportional Control Valves	└	15-26
	27-38	└ GBV100 Proportional Control Valves
GBV200 Proportional Control Valves	└	39-56

GBV60 Proportional Control Valves

Introduction	└	04
	05	└ Dimensions
Standard Spool Flow Characteristics Curves	└	06
	07	└ Technical Specification
Inlet Section Valve Functions and Schematics	└	08
	09	└ Main Valve Functions and Schematics
Drive Types for Main Valve Section	└	10
	11	└ End Section Functions and Schematics
Hydraulic System Examples	└	12
	13-14	└ Ordering Code and Example



Introduction of GBV60

GBV60 Proportional valve is a load sensitive and pre-pressure compensated proportional valve. Because of the pressure compensation, working flow is independent of load. All the proportional valves in this series have been load sensing. We can choose different cartridge unit for the main valve body to accomplish different function. This series valve is building with modular design concept, system designer can choose different module to accomplish various complicated system design. Valve spool can provide excellent flow characteristics and low flow force.

Functions

- Inlet section matches with fixed displacement pump
- Inlet section matches with variable displacement pump
- Multiple control operations
- Overload protections
- Manual proportional valve can provide mechanical and friction detent
- Floating function

Valve Options

- Manually controlled proportional valve or manually controlled flow sharing proportional valve
- Hydraulic pilot controlled proportional valve or hydraulic pilot controlled flow sharing proportional valve
- Electrically controlled proportional valve or electrically controlled flow sharing proportional valve
- Electro-hydraulic proportional valve or electro-hydraulic flow sharing proportional valve

Max flow of this series is 60L/min. Maximun working pressure is 31 MPa, intermittent pressure is 35 MPa.

Electro-Hydraulic proportional valve can use two direct current coils: 12VDC and 24VDC, corresponding current is 0 ~ 1.5 Amp and 0 ~ 0.75 Amp.

Dimensions

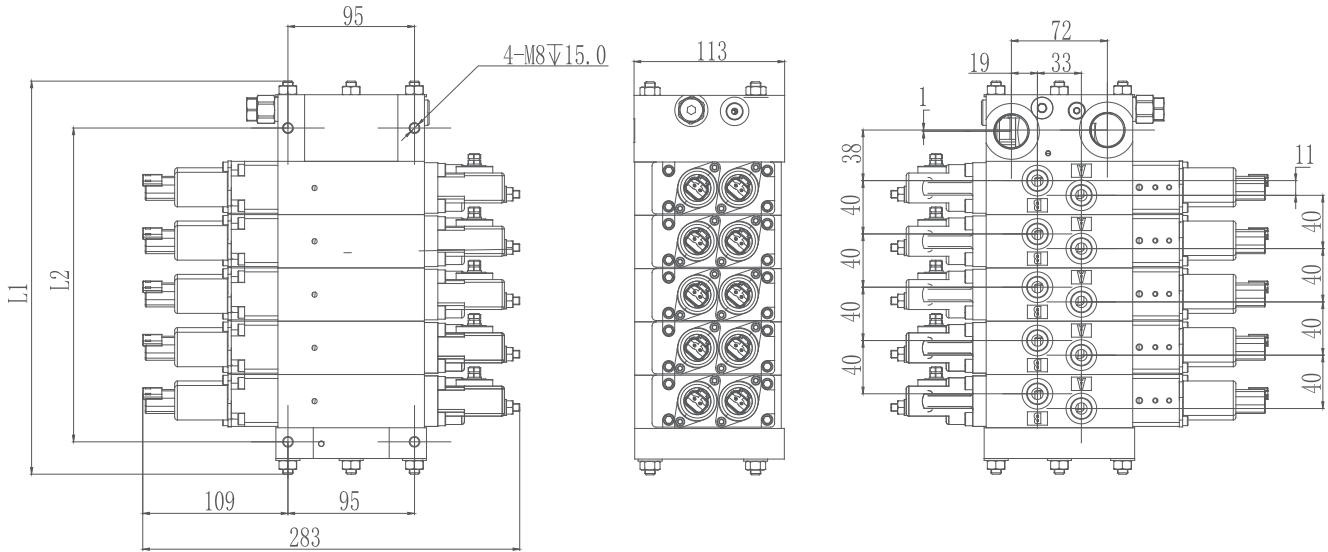

Section		1	2	3	4	5	6	7
L1	mm	135	175	215	255	295	335	375
L2	mm	75.5	115.5	155.5	195.5	235.5	275.5	315.5

Inlet section drawing

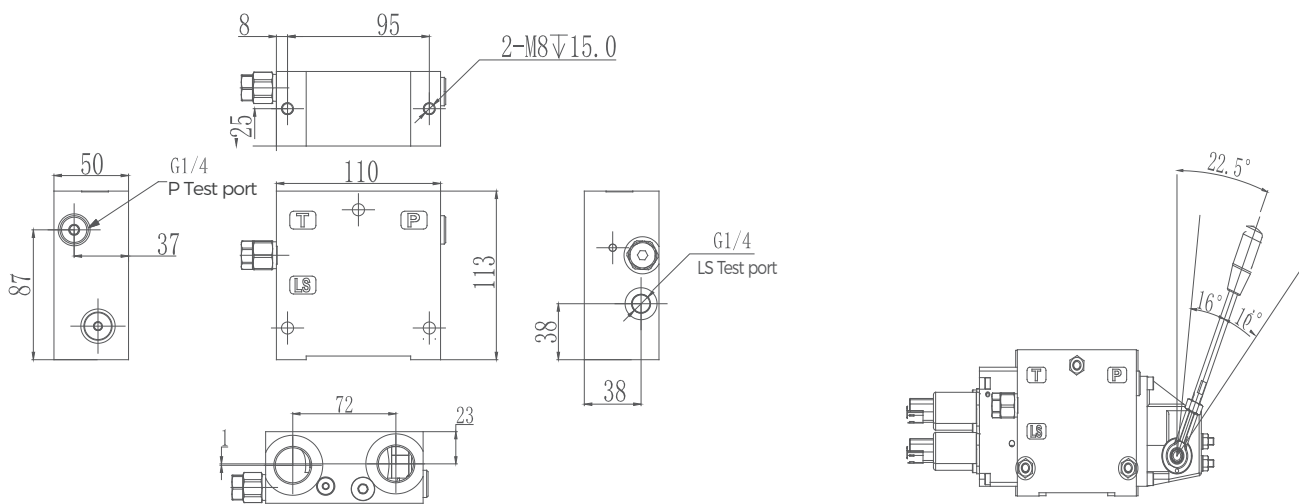

Standard Spool Flow Characteristics

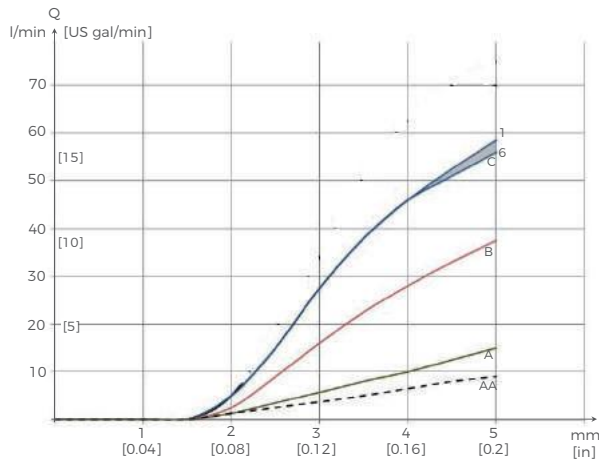

AA, A, B, C indicate spool

All tests are based on 32 @ 21 mm²/s.

Spool stroke and flow rate with open spool.

The flow rate depends on the supply volume (Q).

This characteristic applies to total supply volume of 100 l/min.

1, 6 represent the spool(C)

Load Independent Flow Characteristics (Pressure Compensation)

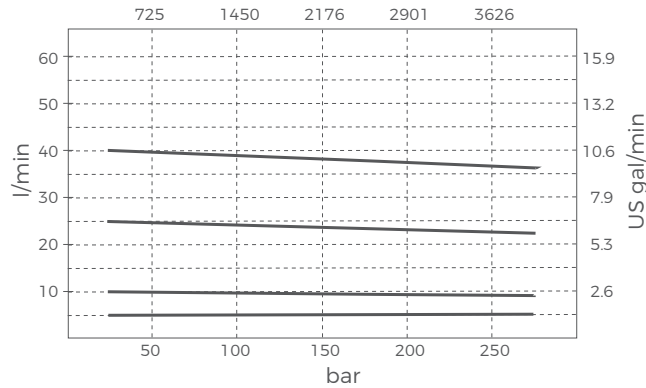

Cartridge Valve Characteristics

GBV60 Buffer Valve

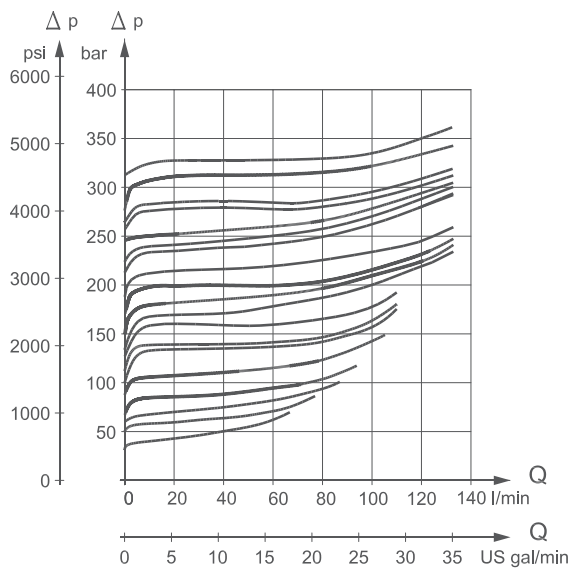

GBV60 Charge Valve

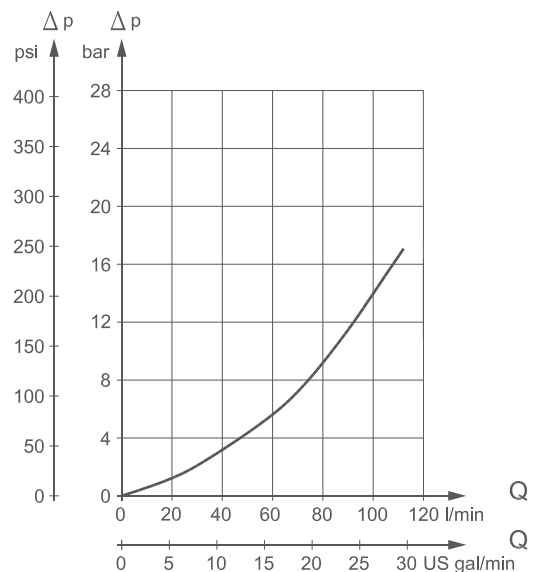

Technical Specification

Max. pressure	P port(Con.)	310 bar	[4495 psi]
	P port(Int.)	350 bar	[5075 psi]
	A/B port(Con.)	310 bar	[4495 psi]
	A/B port(Int.)	350 bar	[5075 psi]
	T port(Static/dynamic)	25/40 bar	[365/580 psi]
Rated flow	P port	100 l/min	[22 US gal/min]
	A/B port	55 l/min	[12 US gal/min]
Spool Stroke	Dead Zone	±1.5 mm	[±0.06 in]
	Proportional range	±5.0 mm	[±0.2 in]
	Floating position	±7.5 mm	[±0.3 in]
Max. internal leakage at 100bar [1450 psi] and 21mm ² [102 SUS]	A/B → T w/o cushion valve	20 cm ³ /min	[1.85 in ³ /min]
	A/B → T cushion valve system setup 30 bar [435 psi]	25 cm ³ /min	[2.15 in ³ /min]
Oil port (Temperature)	Recommend	30 → 60 °C	[86 → 140 °F]
	Min.	-30 °C	[-22 °F]
	Max.	90 °C	[194 °F]
Ambient temperature		-30 → 60 °C	[-22 → 140 °F]

Main Spool Functions

Code	Symbol	Functions	Notes
FG1		Standard 3 position-4 way O type middle function Pre-pressure compensation	Usually used in controlling cylinder
FG2		3 position-4 way Y type middle function Pre-pressure compensation	Usually used in controlling motor
FG3		Standard 3 position-4 way O type middle function 4th position floating Pre-pressure compensation	Usually used in controlling cylinder
FG4		3 position-4 way Y type middle function 4th position floating Pre-pressure compensation	Usually used in controlling cylinder

Inlet Section Valve Functions and Schematics

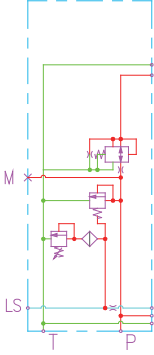
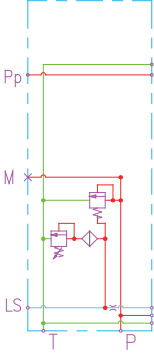
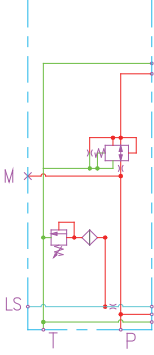
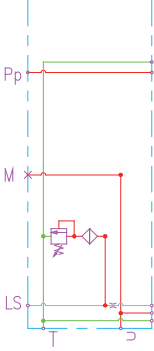
Code	Schematics	Main Functions	Standard Port Sizes
J01		Used in closed circuits with electronically controlled fixed displacement pumps. With pilot oil source.	LS: M14X1.5, G1/4 M: M14X1.5, G1/4 T: M22X1.5, G1/2 P: M22X1.5, G1/2
J02		Used in closed circuits with electronically controlled fixed displacement pumps. Requires external pilot oil source.	Pp: M14X1.5, G1/4 LS: M14X1.5, G1/4 M: M14X1.5, G1/4 T: M22X1.5, G1/2 P: M22X1.5, G1/2
J03		Used in closed circuits with electronically controlled variable displacement pumps. With pilot oil source.	LS: M14X1.5, G1/4 M: M14X1.5, G1/4 T: M22X1.5, G1/2 P: M22X1.5, G1/2
J04		Used in closed circuits with electronically controlled variable displacement pumps. Requires external pilot oil source.	Pp: M14X1.5, G1/4 LS: M14X1.5, G1/4 M: M14X1.5, G1/4 T: M22X1.5, G1/2 P: M22X1.5, G1/2

Main Valve Functions and Schematics

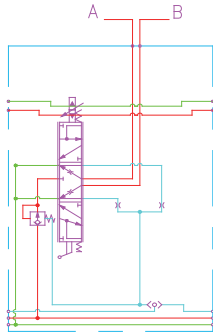
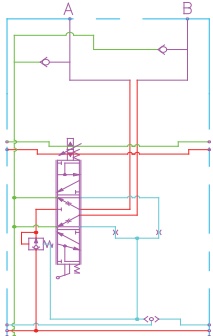
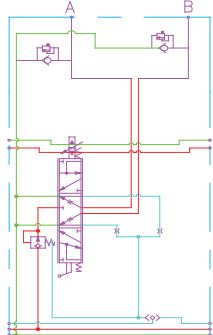
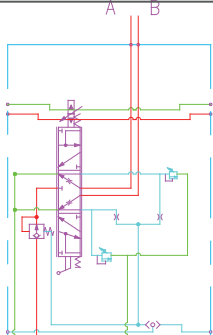
Code	Schematics	Main Functions	Notes
Z01		<p>Pre-pressure compensation (load sensing)</p> <p>Basic module</p>	
Z02		<p>Pre-pressure compensation (load sensing)</p> <p>Oil suction valve at working port prevents system from cavitation</p>	Mostly used for motors
Z03		<p>Pre-pressure compensation (load sensing)</p> <p>Relief valve at the working port to prevent system overload</p> <p>Oil suction valve to prevent the system from cavitation</p>	
Z04		<p>Pre-pressure compensation (load sensing)</p> <p>Relief valve on the LS port of work port to avoid system overloading</p>	



Drive Types for Main Valve Section

Code	Symbol	Functions
Q1		Standard manually operated
Q2		Hydraulic proportional control
Q3		Manually operated with detent
Q4		Manually operated with floating function
Q5		Electric on/off control
Q6		Standard Electro-hydraulic proportional control
Q7		Standard Electro-hydraulic proportional control with manual override
Q8		Standard Electro-hydraulic proportional control with floating function

End Section Functions and Schematics

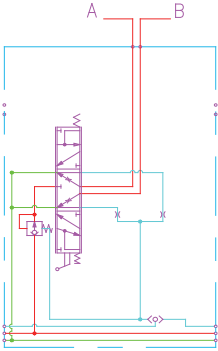
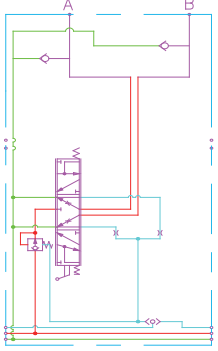
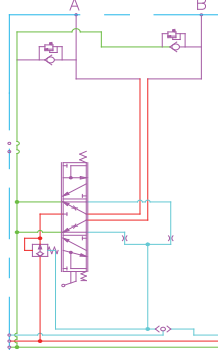
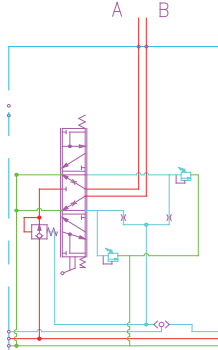
Code	Schematics	Main Functions	Notes
Z05		<p>Pre-pressure compensation (load sensing) Basic valve section</p>	
Z06		<p>Pre-pressure compensation (load sensing) Check valve in working port to prevent air cavitation of system</p>	<p>Mostly used for motors</p>
Z07		<p>Pre-pressure compensation (load sensing) Relief valve in working port to prevent overload and check valve to prevent air cavitation of system</p>	
Z08		<p>Pre-pressure compensation (load sensing) Relief valve on the LS port of work port to avoid system overloading</p>	

Hydraulic System Examples

Electro-hydraulic proportional control circuit with fixed displacement pump
(Pre-pressure compensation)

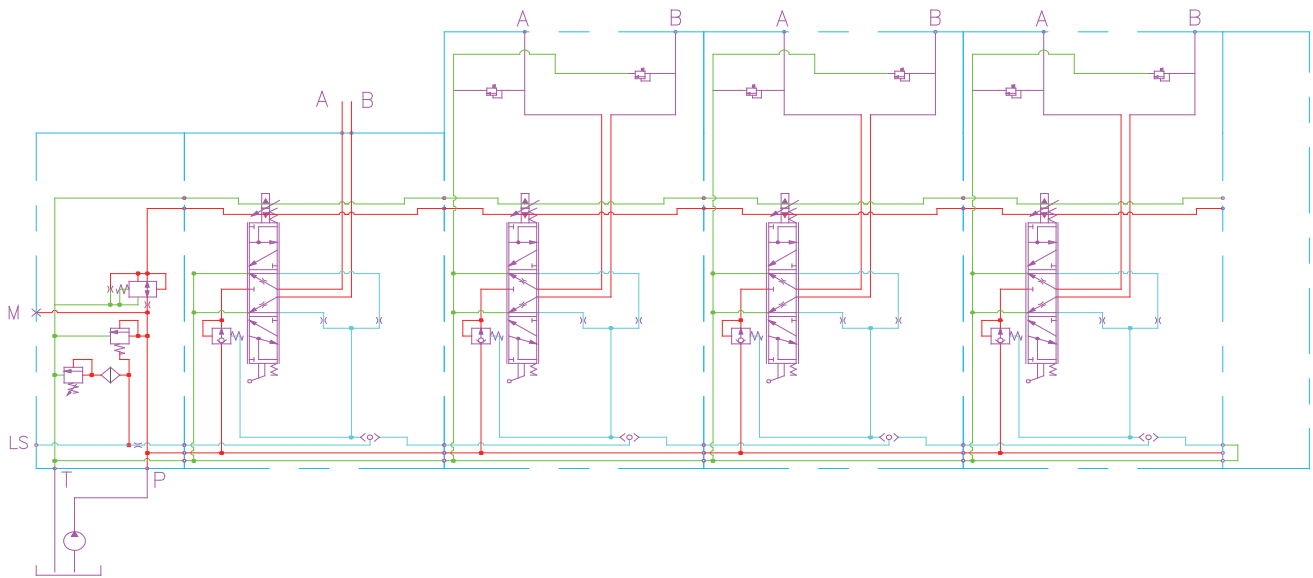

Electro-hydraulic proportional control circuit with variable displacement pump
(Pre-pressure compensation)

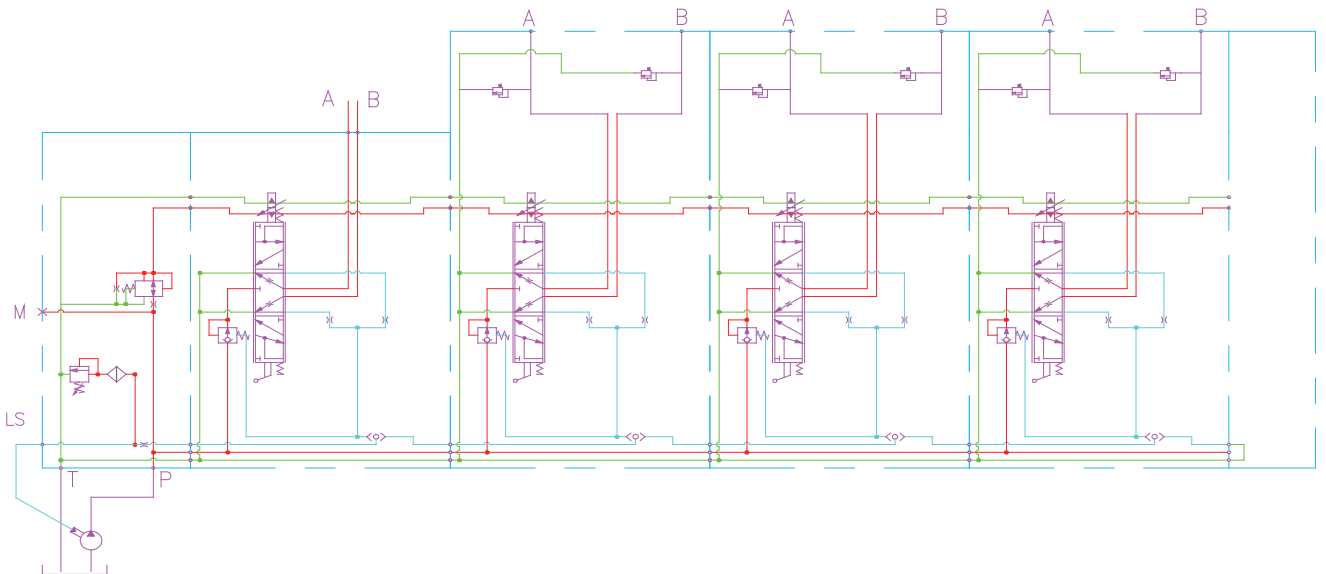

Ordering Code

GBV60	-*	-J**	/***	-D**	-O1	-Z**	Q*	-FG*	-DC/**	-QL/***	-O2	...
a	b	c	d	e	f	g	h	i	j	k	l	m

- | | |
|--|---|
| <ul style="list-style-type: none"> Ⓐ Model Ⓑ Number of main section Ⓒ Inlet section code Ⓓ Main relief valve setting pressure (bar) Ⓔ End section code(End cap)
if no end cap is required use code D00 Ⓕ First main section Ⓖ Main section code | <ul style="list-style-type: none"> Ⓗ Drive style code Ⓘ Spool function code ⓵ Electrical option
12VDC, 24VDC, 00=None electrical Ⓚ Flow rate Ⓛ Second section Ⓜ |
|--|---|

**If the standard port is not selected, please provide the order code and the port size.

Ordering Example

GBV60	-3	-J03	/210	-D00	-O1	-Z02	-Q6	-FG1	-DC/24	-QL/60
a	b	c	d	e	f	g	h	i	j	k

- | | |
|--|---|
| <ul style="list-style-type: none"> Ⓐ Model Ⓑ Three main sections Ⓒ Inlet code Ⓓ Relief setting 210bar Ⓔ No end cap Ⓕ First section | <ul style="list-style-type: none"> Ⓖ Main section code Ⓗ Drive style Ⓘ Spool function ⓵ 24VDC Ⓚ Flow 60L/min |
|--|---|

-O2	-Z01	-Q6	-FG1	-DC/24	-QL/50
l	m	n	o	p	q

-O3	-Z01	-Q6	-FG1	-DC/24	-QL/40
r	s	t	u	v	w

Ⓛ Second section

Ⓜ Main section code

Ⓝ Drive style code

Ⓞ Spool function code

Ⓟ 24VDC

Ⓠ Flow 40L/min

Ⓡ Third section

Ⓢ Main section code

Ⓣ Drive style code

Ⓤ Spool function code

Ⓡ 24VDC

Ⓢ Flow 30L/min

Ordering example notes: From system example, the selected valve is GBV60 series, we know that the valve has three sections. Inlet relief valve setting pressure is 21MPa. There is no end section. Return from inlet section, the first section has no load relief valve. The section is driven by 24VDC coils. The spool middle function is a O type. The required flow is 60L/min. The second section is also driven by 24VDC coils. There is no overload relief on neither A or B port. The spool middle function is O type, The required flow is 40L/min. The third section is driven by 24VDC coils. No overload relief on neither A or B port. Spool middle function is O type. The required flow is 30L/min.

Proportional Control Valves

GBV80 Proportional Control Valves	└	15-26	
		27-38	└ GBV100 Proportional Control Valves
GBV200 Proportional Control Valves	└	39-56	

GBV80 Proportional Control Valves

Introduction	└	16	
		17	└ Dimensions
Standard Spool Flow Characteristics Curves	└	18	
		19	└ Technical Specification
Inlet Section Valve Functions and Schematics	└	20-21	
		22	└ Main Valve Functions and Schematics
Drive Types for Main Valve Section	└	23	
		24	└ End Section Functions and Schematics
Hydraulic System Examples	└	25	
		26	└ Ordering Code and Example

GBV80 Load-Sensing Proportional Control Valve Introduction

GBV80 is a load-sensing proportional hydraulic control valve, designed to achieve optimal equipment performance and maximum design flexibility. The control valve adopts a modular concept, allowing equipment designers to customize solutions to meet diverse applications in the diverse market. It belongs to the GBV product platform and interface of other valve series, enabling a single valve block to control all machine functions.

It can regulate a maximum operating flow rate of 125 L/min [33 US gal/min] and an operating oil pressure of up to 420 bar [6090 psi].

Load-independent proportional control, high-performance electro-hydraulic technology, and low-pressure-drop design optimize equipment performance and efficiency, increasing productivity while reducing energy consumption.

GBV80 Features

The features and advantages of the GBV80 load-sensing proportional valve are summarized as follows:

- Load-independent flow control:
 - The supply flow to a specific actuator is independent of its load pressure
 - The supply flow to a specific actuator is independent of the load pressure of other actuators
- When using the interface module, it can be combined with other products in the GBV series
- Each GBV80 valve bank can be equipped with up to 12 working modules
- Excellent speed adjusting characteristics
- Pressure reduction at ports A and B reduces energy loss while achieving the required pressure
- Pipe joint and flange connection options
- Compact design, easy to install and maintain
- Energy-efficient
- Lightweight

Other Technical Characteristics

The features of the oil inlet, working module housing, and actuation methods are as follows:

Oil Inlet Includes:

- Internal flow control valve
- Pressure test port
- Applicable to different types of models:

Open circuit system, with fixed-displacement pump

Closed circuit system, with variable-displacement pump

- Integrated pilot oil supply

Working Module Housing Includes:

- Replaceable valve spool
- Pressure test port
- Applicable to models for different application requirements:

Internal compensator for load-independent flow

P-channel integrated load-holding check valve

Integrated pilot pressure compensator

Integrated local drain valve

Actuation Methods Include:

- Manual control:
 - With handle
 - With friction positioning
- Hydraulic control
- Electro-hydraulic control:
 - On/off control
 - Proportional control
 - CAN bus proportional control
 - PWM proportional control

Dimensions

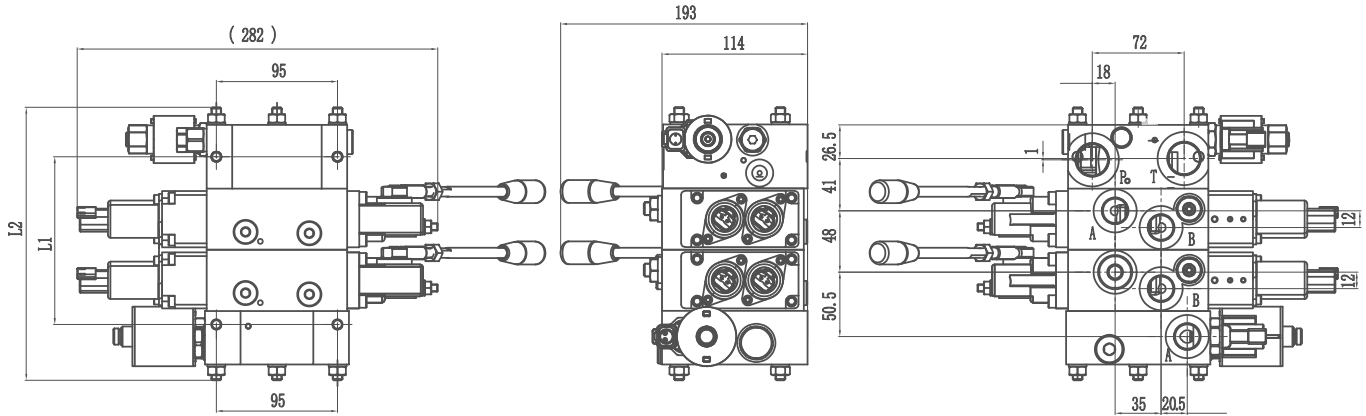

Section		1	2	3	4	5	6	7	8
L1	mm	83	131	179	227	275	323	371	419
L2	mm	118	166	214	262	310	358	406	454

Inlet section drawing

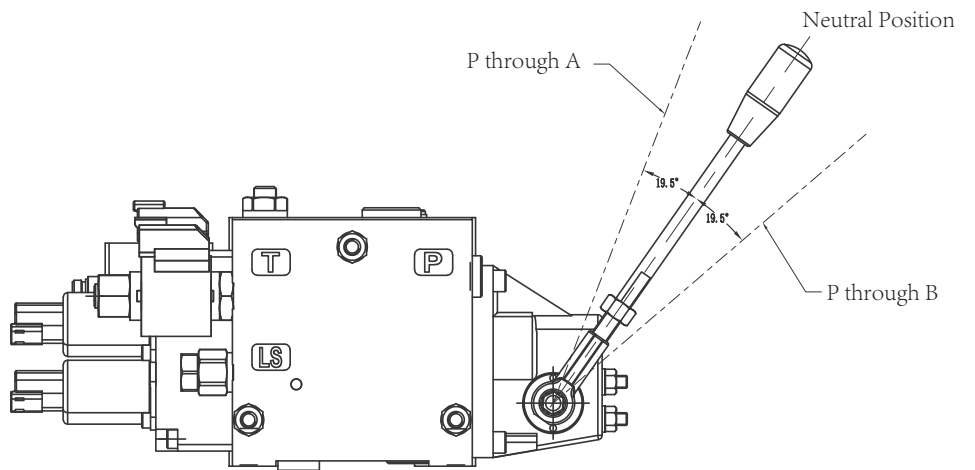
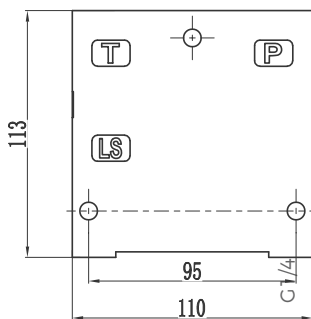
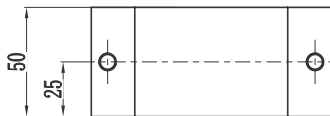

Fixed displacement pump

Variable displacement pump



Main valve body pressure compensation curve

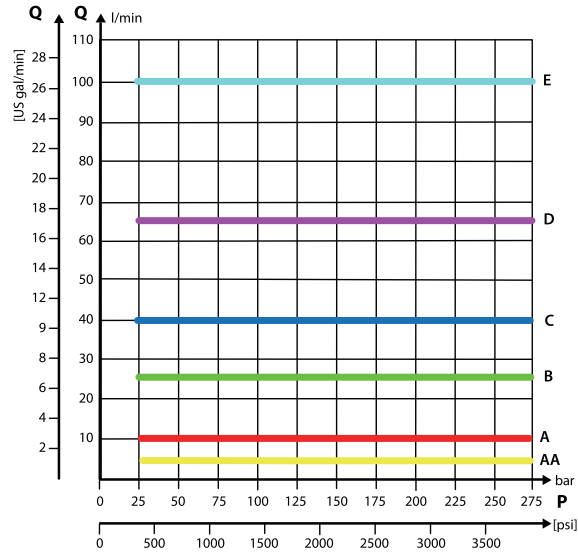

Main valve body LS A/B pressure curve

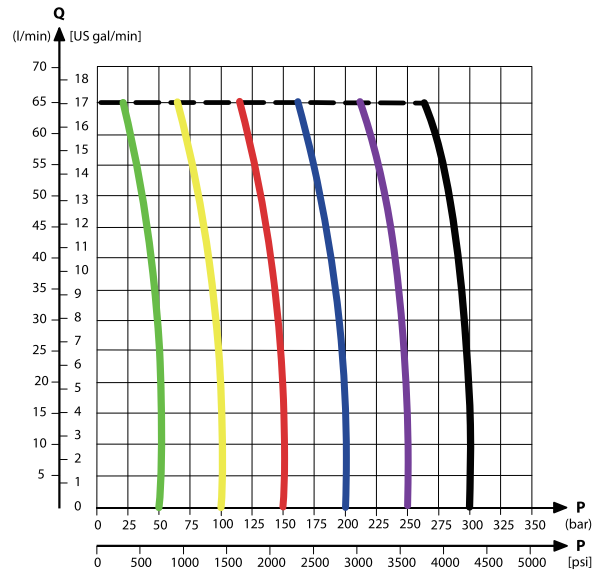

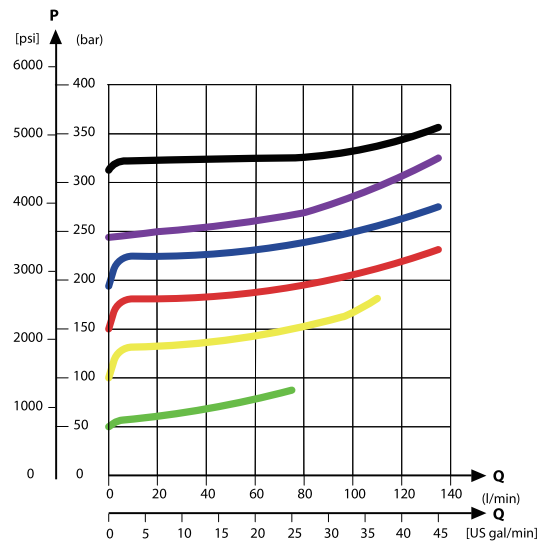

Main valve body cushion valve pressure curve



Technical Parameters

Maximum Pressure	Port P Continuous	310 bar
	Port P Intermittent	350 bar
	Ports A/B Continuous	310 bar
	Ports A/B Intermittent	350 bar
	Port T Static/Dynamic	25/40 bar
Rated Flow	Port P	140 l/min
	Ports A/B	120 l/min
Spool Stroke	Dead Zone	±1.5 mm
	Proportional Range	±7.0 mm
Maximum Internal Leakage@ 100bar [1450 psi]&21mm ² [102 SUS]	A/B→T without Cushion Valve	20cm ³ /min
	A/B→T with Cushion Valve 30bar [435 psi] System Set 30 bar [435 psi]	25cm ³ /min
Port Temperature	Recommended Temperature	30 → 60 °C
	Minimum Temperature	-30 °C
	Maximum Temperature	90 °C
Ambient Temperature		-30 → 60 °C

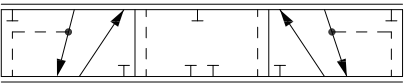
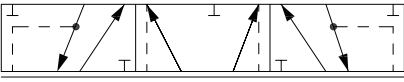
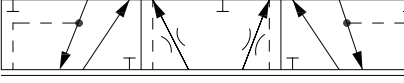
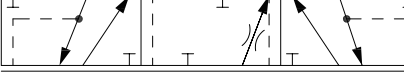
Spool Functions

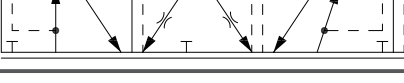
Code	Schematics	Main Functions
FG1		Flow Control Spool - Closed Neutral
FG2		Flow Control Spool - Open Neutral
FG3		Flow Control Spool - Throttle Open Neutral
FG4		Flow Control Spool - Throttle A-T Neutral
FG5		Flow Control Spool - Throttle B-T Neutral
FG6		O-Type Function 4th Section Float Pre-Position Compensation
FG7		Y-Type Function 4th Section Float Pre-Position Compensation

Inlet Section Valve Functions and Schematics

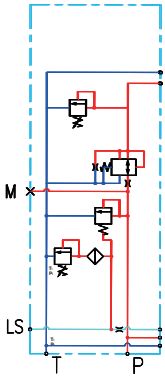
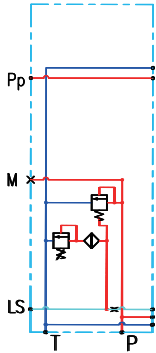
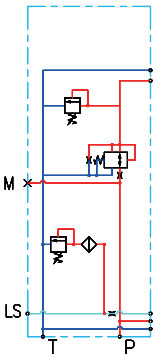
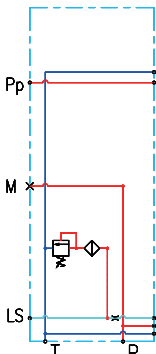
Code	Schematics	Main Functions	Notes
J01		<p>Used in closed circuits with electronically controlled fixed displacement pumps. Requires external pilot oil source.</p>	<p>P,T:G3/4;A,B:G1/2</p>
J02		<p>Used in closed circuits with electronically controlled fixed displacement pumps. With pilot oil source.</p>	<p>P,T:G3/4;A,B:G1/2</p>
J03		<p>Used in closed circuits with electronically controlled fixed displacement pumps. Requires external pilot oil source.</p>	<p>P,T:G3/4;A,B:G1/2</p>
J04		<p>Used in closed circuits with electronically controlled fixed displacement pumps. With pilot oil source.</p>	<p>P,T:G3/4;A,B:G1/2</p>

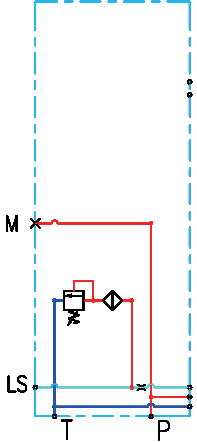
Code	Schematics	Main Functions	Notes
J05		<p>Used in closed circuits with electronically controlled fixed displacement pumps. Requires external pilot oil source.</p>	<p>P,T:G3/4;A,B:G1/2</p>

Main Valve Functions and Schematics

Code	Schematics	Main Functions	Notes
Z01		Pre-position pressure compensation (proportional distributor) Basic module	
Z02		Pre-position pressure compensation (proportional distributor) Work port with suction valve anti-cavitation	Mostly used for motors
Z03		Pre-position pressure compensation (proportional distributor) Work port with relief valve to prevent system overload and suction valve. anti-cavitation	
Z04		Pre-position pressure compensation (proportional distributor) Work port with relief valve to prevent system overload A,B with LS pressure protection valve	

Drive Types for Main Valve Section

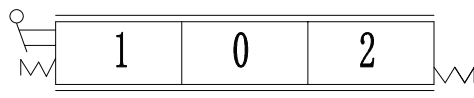
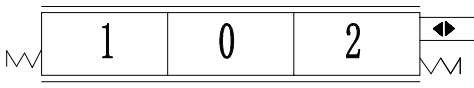
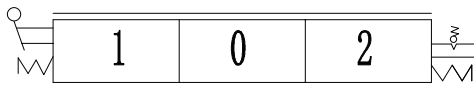
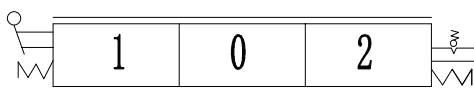
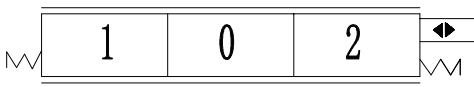
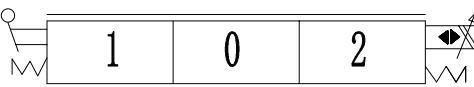
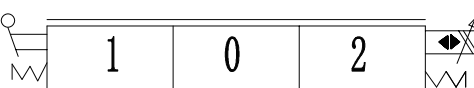
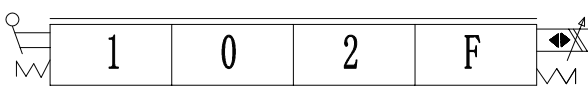
Code	Symbol	Functions
Q1		Standard manually operated
Q2		Hydraulic control
Q3		Manually operated with detent
Q4		Manually operated with floating function
Q5		Electric on/off control
Q6		Standard Electro-hydraulic proportional control
Q7		Standard Electro-hydraulic proportional control with manual override
Q8		

End Section Functions and Schematics

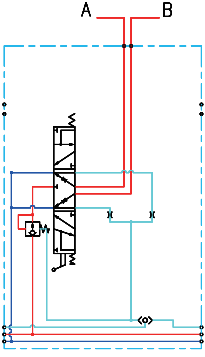
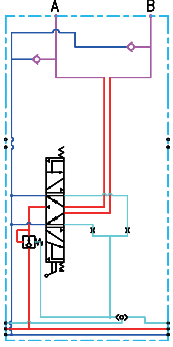
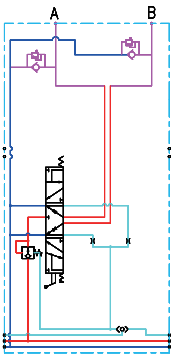
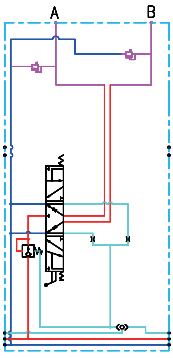
Code	Schematics	Main Functions	Notes
Z05		Pre-pressure compensation (load sensing) Basic module	
Z06		Pre-pressure compensation (load sensing) Check valve in working port to prevent air cavitation of system	Mostly used for motors
Z07		Pre-pressure compensation (load sensing) Relief valve in working port to prevent overload and check valve to prevent air cavitation of system	
Z08		Pre-pressure compensation (load sensing) Relief valve on the LS port of work port to avoid system overloading	

Hydraulic System Examples

Hydraulic schematic diagram

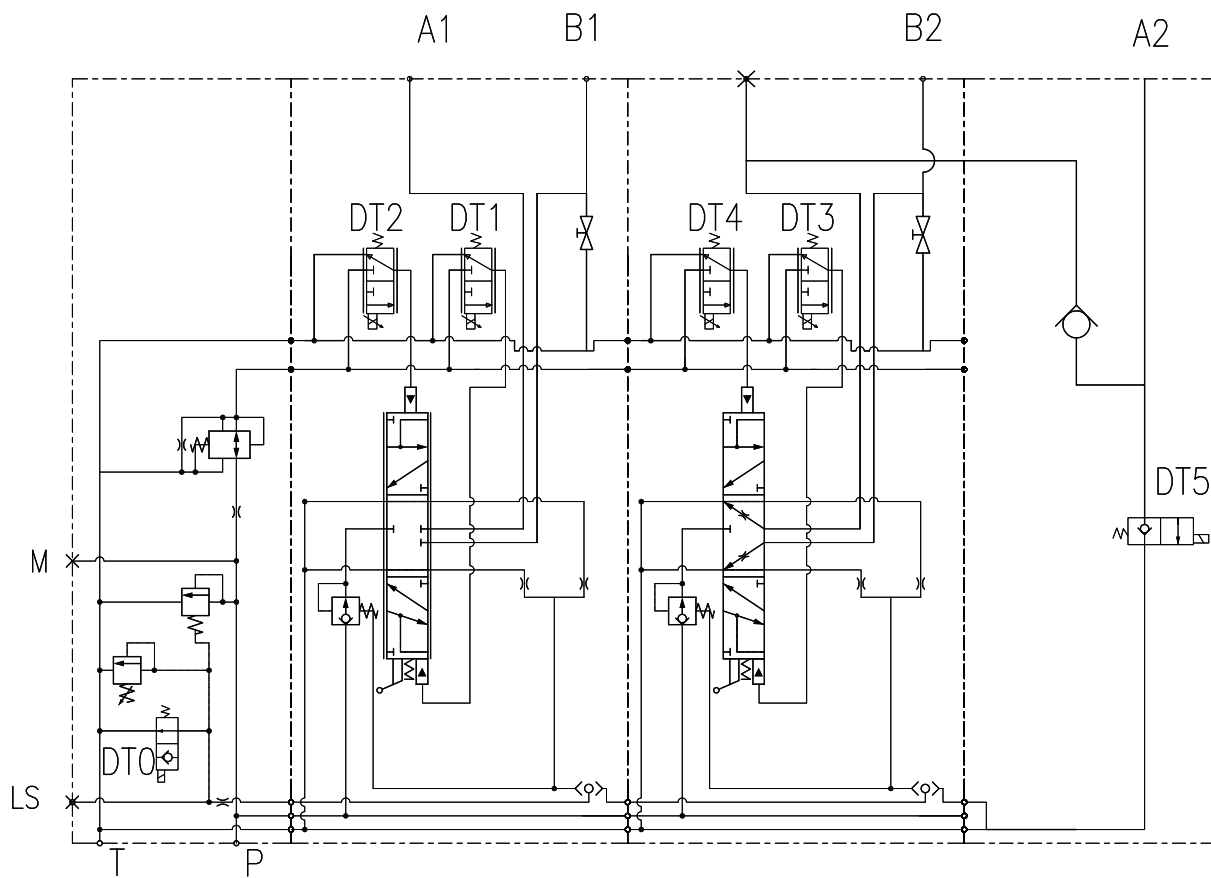

Ordering Code

GBV80	-*	-J**	/***	-D**	-O1	-Z**	Q*	-FG*	-DC/**	-QL/***	-O2	...
a	b	c	d	e	f	g	h	i	j	k	l	m

- Ⓐ Model
- Ⓑ Number of main section
- Ⓒ Inlet section code
- Ⓓ Main relief valve setting pressure (bar)
- Ⓔ End section code(End cap)
if no end cap is required use code D00
- Ⓕ First main section
- Ⓖ Main section code
- Ⓗ Drive style code
- Ⓘ Spool function code
- Ⓚ Electrical option
12VDC, 24VDC, 00=None electrical
- Ⓛ Flow rate
- Ⓜ Second section
- Ⓝ

**If the standard port is not selected, please provide the order code and the port size.

Ordering Example

GBV80	-3	-J03	/210	-D00	-O1	-Z02	-Q6	-FG1	-DC/24	-QL/80
a	b	c	d	e	f	g	h	i	j	k

- Ⓐ Model
- Ⓑ Three main sections
- Ⓒ Inlet code
- Ⓓ Relief setting 210bar
- Ⓔ No end cap
- Ⓕ First section
- Ⓖ Main section code
- Ⓗ Drive style
- Ⓘ Spool function
- Ⓚ 24VDC
- Ⓛ Flow 80L/min

-O2	-Z01	-Q6	-FG1	-DC/24	-QL/80
l	m	n	o	p	q

-O3	-Z01	-Q6	-FG1	-DC/24	-QL/30
r	s	t	u	v	w

- Ⓛ Second section
- Ⓜ Main section code
- Ⓝ Drive style code
- Ⓚ Spool function code
- Ⓟ 24VDC
- Ⓠ Flow 80L/min
- Ⓡ Third section
- Ⓢ Main section code
- Ⓣ Drive style code
- Ⓚ Spool function code
- Ⓟ 24VDC
- Ⓡ Flow 30L/min

Ordering example notes: From system example, the selected valve is GBV80 series, we know that the valve has three sections. inlet relief valve setting pressure is 21MPa. There is no end section. Return from inlet section, the first section has no load relief valve. The section is driven by 24vDc coils. The spool middle function is a 0 type. The required flow is 60L/min. The second section is also driven by 24vDc coils. There is no overload relief on neither A or B port. The spool middle function is O type, The required flow is 40L/min. The third section is driven by 24VDc coils. No overload relief on neither A or B port. spool middle function is O type. The required flow is 30L/min.

Proportional Control Valves

	27-38	└ GBV100 Proportional Control Valves
GBV200 Proportional Control Valves	└	39-56

GBV100 Proportional Control Valves

Introduction	└	28
		29
	└	Dimensions
Characteristic for Standard Spool	└	29
		30
	└	Inlet Section Valve Function and Schematics
Inlet Section Dimension	└	31
		32
	└	Main Valve Function and Schematics
Rear Cover Function and Schematics	└	33
		34
	└	Drive Types for Main Valve Section
Hydraulic System Examples	└	35
		36
	└	Hydraulic System Examples
Ordering Code and Example	└	37-38

Introduction of GBV100

GBV100 Proportional valve is a load sensitive and post-pressure compensated proportional valve. For post-pressure compensation valve, it can distribute flow proportionally for each working function. Because of the pressure compensation, working flow is independent of load. All the proportional valves in this series have been load sensing and spring return. We can choose different cartridge unit for the main valve body to accomplish different function. This series valve is building with modular design concept, system designer can choose different module to accomplish various complicated system design. Valve spool can provide excellent flow characteristics and low flow force.

Functions

- Inlet section matches with fixed displacement pump
- Inlet section matches with variable displacement pump
- Multiple control operations
- Overload protections
- Manual proportional valve can provide mechanical and friction detent
- Main valve with float function

Valve Options

- Manually controlled proportional valve or mechanically controlled flow sharing proportional valve
- Hydraulic pilot controlled proportional valve or hydraulic pilot controlled flow sharing proportional valve
- Electrically controlled on/off valve or electrically controlled flow sharing proportional valve
- Electro-hydraulic proportional valve or electro-hydraulic flow sharing proportional valve

Max flow of this series is 100L/min. Rated pressure is 31MPa. Inermittent pressure is 35 MPa.

Electro-Hydraulic proportional valve can use two direct current coils: 12VDC and 24VDC, corresponding current is 0 ~ 1.5 Amp and 0 ~ 0.75 Amp.

Dimensions

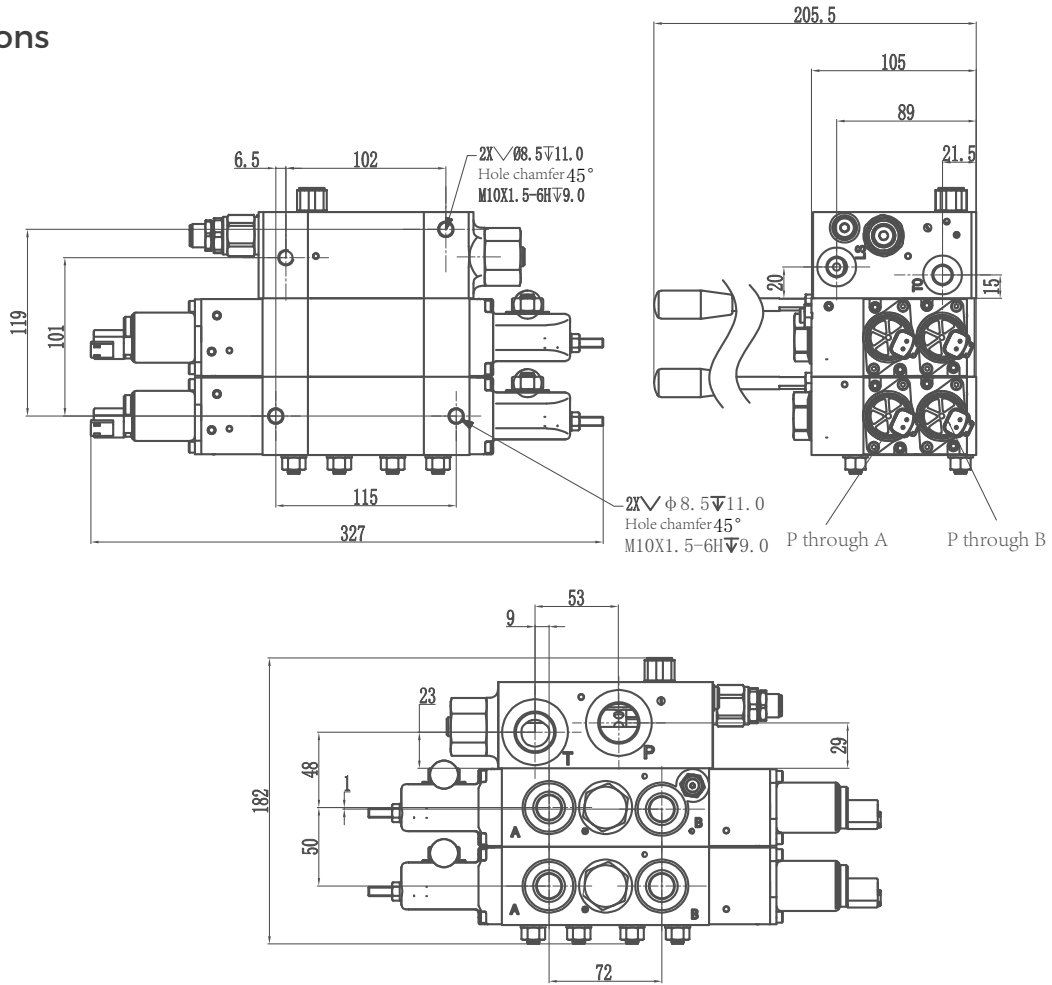

Characteristic for Standard Spool

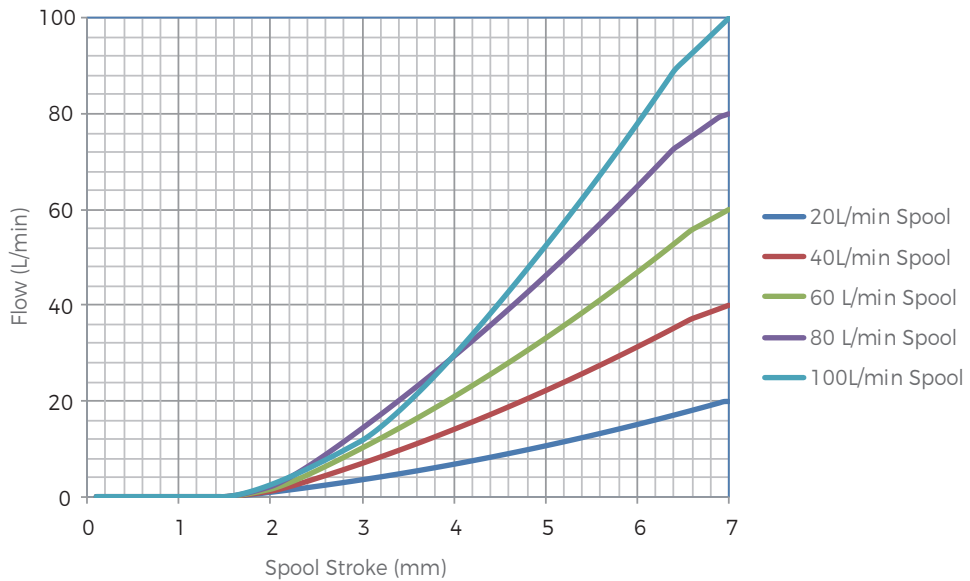

Inlet Section Valve Functions and Schematics

Code	Schematics	Functions	Standard Port Sizes
J01		Used in fixed displacement pump system with pilot oil source	Pg: M14X1.5, G1/4 TO: M14X1.5, G1/4 T: M27X2, G3/4 P: M27X2, G3/4
J02		Used in closed circuits with fixed displacement pumps. Requires external pilot oil source	Pp: M14X1.5, G1/4 Pg: M14X1.5, G1/4 TO: M14X1.5, G1/4 T: M27X2, G3/4 P: M27X2, G3/4
J03		Used in closed circuits for variable displacement pumps with pilot oil source	LS: M14X1.5, G1/4 Pg: M14X1.5, G1/4 TO: M14X1.5, G1/4 T: M27X2, G3/4 P: M27X2, G3/4
J04		Used in closed circuits with variable displacement pumps. Requires external pilot oil source	LS: M14X1.5, G1/4 Pp: M14X1.5, G1/4 Pg: M14X1.5, G1/4 TO: M14X1.5, G1/4 T: M27X2, G3/4 P: M27X2, G3/4

Inlet Section Dimensions

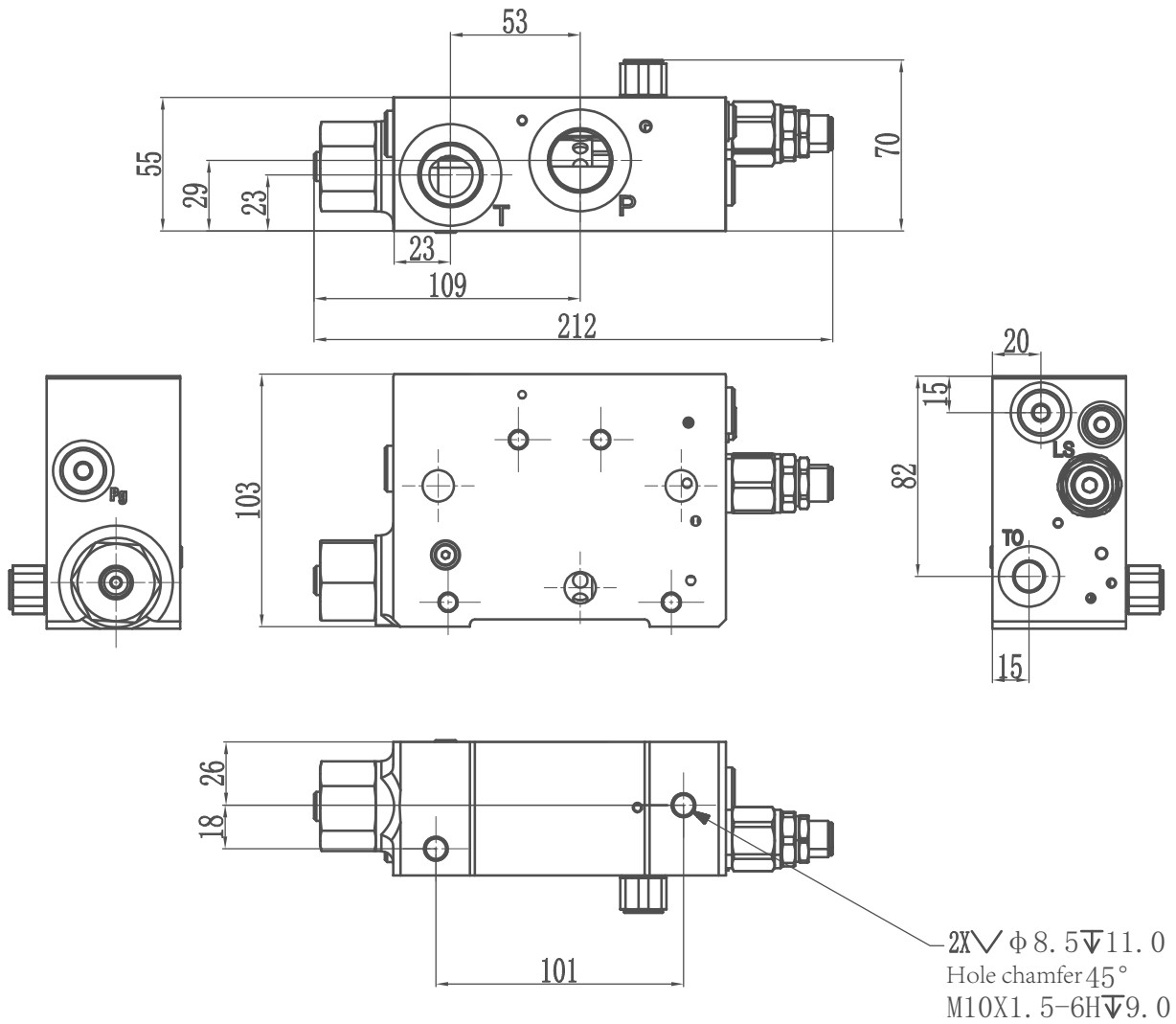

Main Valve Functions and Schematics

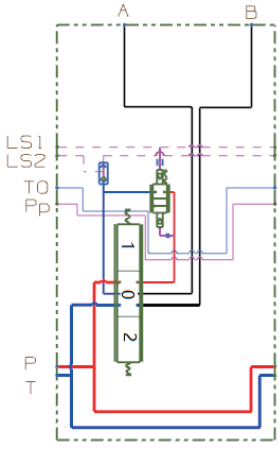
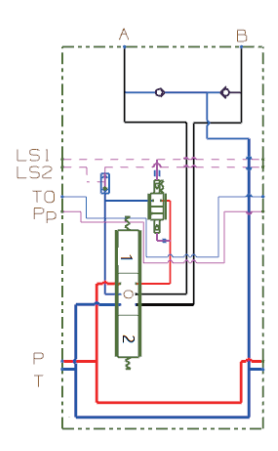
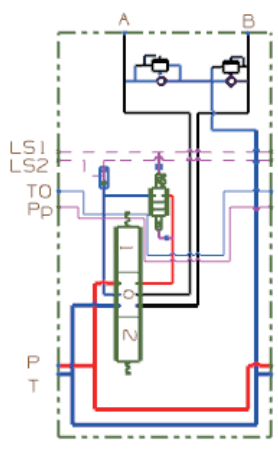
Code	Schematics	Functions	Notes
Z01		<p>Post-pressure compensation (proportional flow sharing) Basic valve body</p>	<p>Standard port sizes Working oil ports A and B: M27×2, G3/4</p>
Z02		<p>Post-pressure compensation (proportional flow sharing) Check valve in working port to prevent cavitation of system</p>	<p>Usually used in hydraulic motor</p>
Z03		<p>Post-pressure compensation (proportional flow sharing) Relief valve in working port to prevent overload and check valve to prevent cavitation of system</p>	

End Cap Functions and Schematics

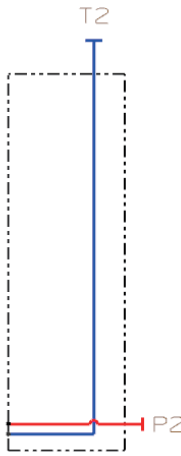
Code	Schematics	Functions	Notes
D01		Usually used with fixed displacement pump	Port Size T2: M27×2 P2: G3/4



Drive Types for Main Valve Section

Code	Symbol	Functions
Q1		Standard manually operated
Q2		Hydraulic control
Q3		Manually operated with detent
Q4		Manually operated with floating function
Q5		Electric control(on/off)
Q6		Standard electro-hydraulic proportional control
Q7		Standard electro-hydraulic proportional control with manual override
Q8		Standard electro-hydraulic proportional control with floating function

Main Spool Functions

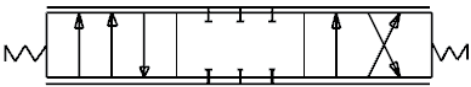
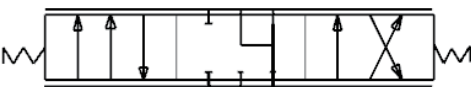
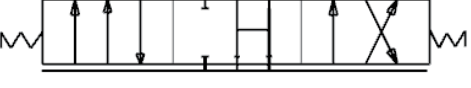
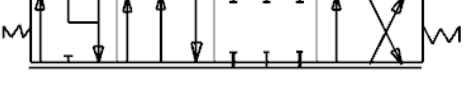
Code	Spool Type	Functions	Notes
FG1		Standard 3 position-4 way O middle function Post-pressure compensation	Usually used in controlling cylinder
FG2		3 position-4 way Y middle function Post-pressure compensation	Usually used in controlling motor
FG3		3 position-4 way H middle function Post-pressure compensation	Usually used in controlling cylinder
FG4		Standard 4 position-4 way with floating function Post-pressure compensation	Usually used in controlling cylinder

** All spools are spring centered.

Hydraulic System Examples

Electro-hydraulic Proportional Control System with Variable Displacement Pump
(Post-pressure Compensation)

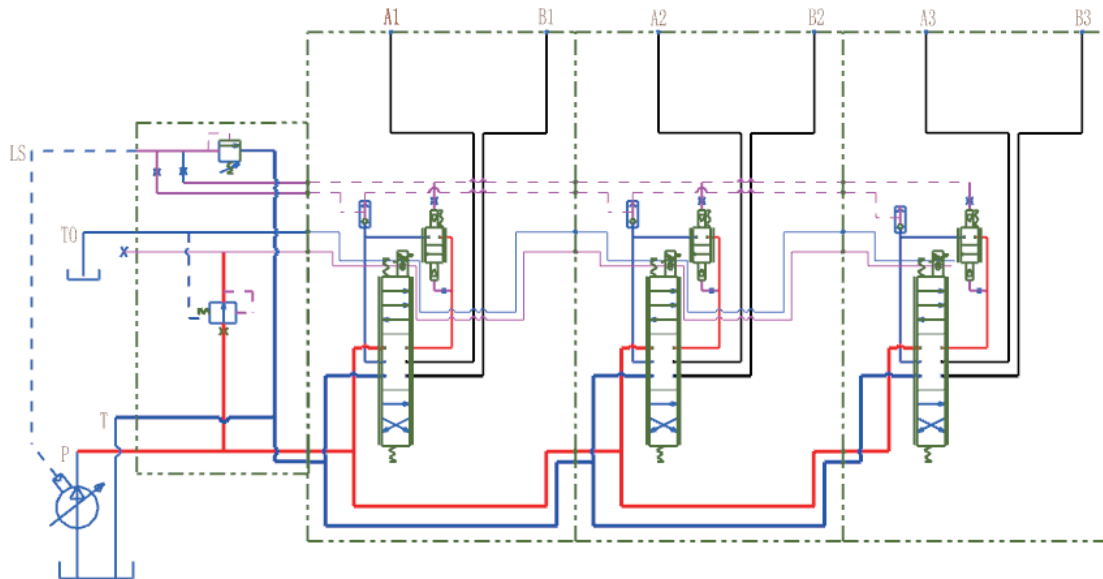

Electro-hydraulic Proportional Control System with Fixed Displacement Pump
(Post-pressure Compensation)

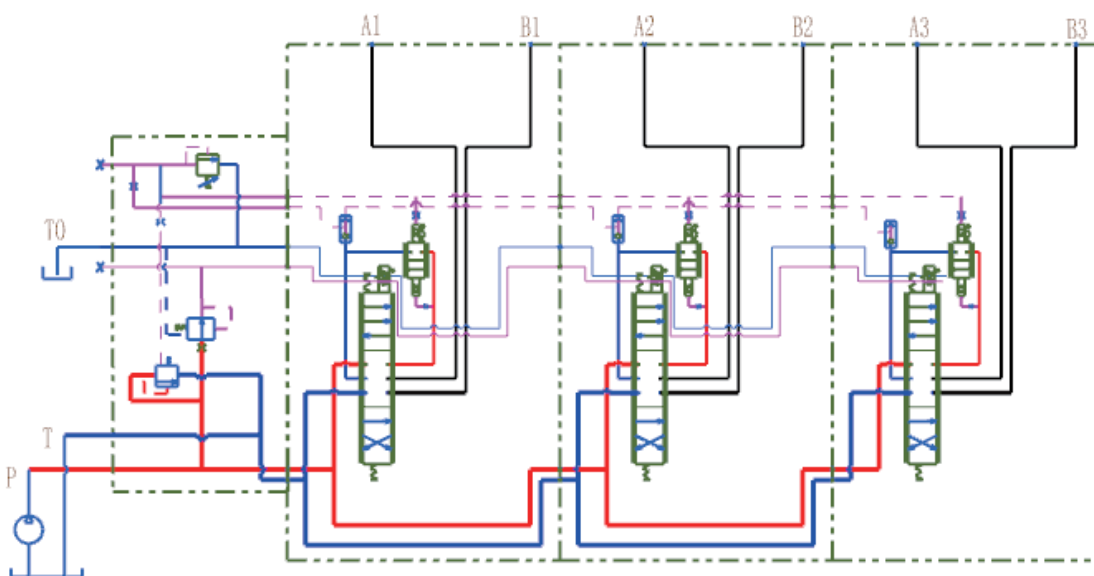

Ordering Code

GBV100	-*	-J**	/***	-D**	-O1	-Z**	Q*	-FG*	-DC/**	-QL/***	-O2	...
a	b	c	d	e	f	g	h	i	j	k	l	m

- | | |
|---|---|
| <ul style="list-style-type: none"> Ⓐ Model Ⓑ Number of main section Ⓒ Inlet section code Ⓓ Relief setting (bar) Ⓔ End section code (End cap) without end section use code D00 Ⓕ First main section Ⓖ Main section code | <ul style="list-style-type: none"> Ⓗ Drive style code Ⓘ Spool function code Ⓝ Electrical option
12VDC, 24VDC, 00=None electrical Ⓚ Flow rate Ⓛ Second section Ⓜ |
|---|---|

**Port Size: If user do not want our standard size, you have to not only provide ordering code, but also you have to specify all the port sizes.

Ordering Example

GBV100	-3	-J03	/210	-D00	-O1	-Z02	-Q6	-FG1	-DC/24	-QL/100
a	b	c	d	e	f	g	h	i	j	k

- | | |
|--|--|
| <ul style="list-style-type: none"> Ⓐ Model Ⓑ Three main sections Ⓒ Inlet code Ⓓ Relief setting pressure Ⓔ No end cap Ⓕ First section | <ul style="list-style-type: none"> Ⓖ Main section code Ⓗ Drive style Ⓘ Spool function Ⓝ 24VDC Ⓚ Flow 100L/min |
|--|--|



-O2	-Z01	-Q6	-FG1	-DC/24	-QL/80
l	m	n	o	p	q

-O3	-Z01	-Q6	-FG1	-DC/24	-QL/30
r	s	t	u	v	w

- Ⓛ Second section
- Ⓜ Main section code
- Ⓝ Drive style code
- Ⓞ Spool function code
- Ⓟ 24VDC
- Ⓠ Flow 80L/min

- Ⓡ Third section
- Ⓢ Main section code
- Ⓣ Drive style code
- Ⓤ Spool function code
- Ⓡ 24VDC
- Ⓢ Flow 30L/min

Ordering Example Description: The selected valve is GBV100 series, with three sections, a relief valve in the inlet section with a set pressure of 21 MPa, and no end cap (return from the inlet section). The first section is electro-hydraulic proportional drive, "A" and "B" port are no overload valve, using DC voltage 24 volts. The neutral is "O" type, which requires the first section to provide a flow rate of 60 l/min. The second section is electro-hydraulic proportional drive using 24 volts DC. The "A" and "B" ports have no overload protection valves and the neutral is an "O" type, which is required to provide a flow rate of 40 l/min. The third section is an electro-hydraulic proportional drive, with no overload protection valves on the "A" and "B" ports, with an "O" type neutral position, and requires a flow rate of 30 l/min.



Proportional Control Valves

39-56 **L** GBV200 Proportional Control Valves

GBV200 Proportional Control Valves

Introduction L	40	
	41	L Dimensions
Flow Characteristic for Standard Spools L	42	
	43-44	L Inlet Section Valve Function and Schematics
Inlet Section Dimensions L	45-46	
	47-50	L Main Valve Function and Schematics
End Cap Function and Schematics L	51	
	51	L End Section Dimensions
Drive Types for Main Valve Section L	52	
	53	L Main Spool Functions
Hydraulic System Examples L	54	
	55-56	L Ordering Code and Example



Introduction of GBV200

GBV200 Proportional valve is a load sensitive and post-pressure compensated proportional valve. For post-pressure compensation valve, it can distribute flow proportionally. Because of the pressure compensation, working flow is independent of load. All the proportional valves in this series have been load sensing and spring return. We can choose different cartridge unit for the main valve body to accomplish different function.

This series valve is building with modular design concept, system designer can choose different module to accomplish various complicated system design. Valve spool can provide excellent flow characteristics and low flow force.

Functions

- Inlet section with priority valves
- Inlet section matches with fixed displacement pump
- Inlet section matches with variable displacement pump
- P. O. Check Valve
- One-way throttle valve
- Multiple control operations
- Overload protections
- Manual proportional valve can provide mechanical positioning, friction positioning
- Manual proportional valve can provide floating function
- Overload protections
- Manual proportional valve can provide mechanical and friction function
- Manual proportional valve can provide main valve with float function

Valve Options

- Manually controlled proportional valve or mechanically controlled flow sharing proportional valve
- Hydraulic pilot controlled proportional valve or hydraulic pilot controlled flow sharing proportional valve
- Electrically controlled on/off valve or electrically controlled flow sharing proportional valve
- Electro-hydraulic proportional valve or electro-hydraulic flow sharing proportional valve
- Mixture proportional valve (sections with proportional flow sharing and pre-pressure compensation)

Max flow of this series is 220L/min. Rated pressure is 31MPa. Intermittent pressure is 35 MPa.

Electro-Hydraulic proportional valve can use two direct current coils: 12VDC and 24VDC, corresponding current is 0 ~1.5 Amp and 0 ~ 0.75 Amp.

Dimensions

Three Sections Electro-hydraulic Proportional Valve

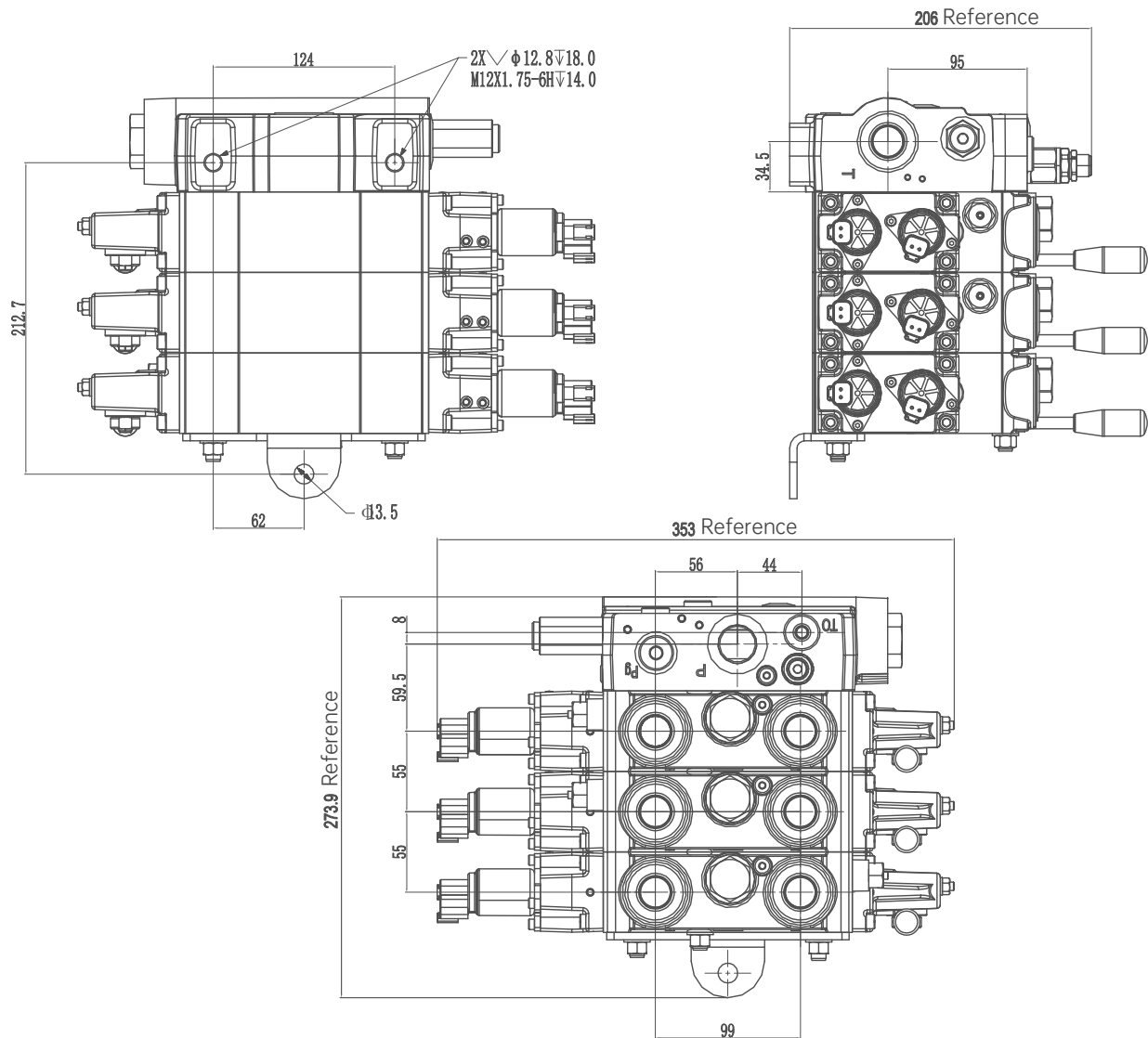



Flow Characteristic for Standard Spool

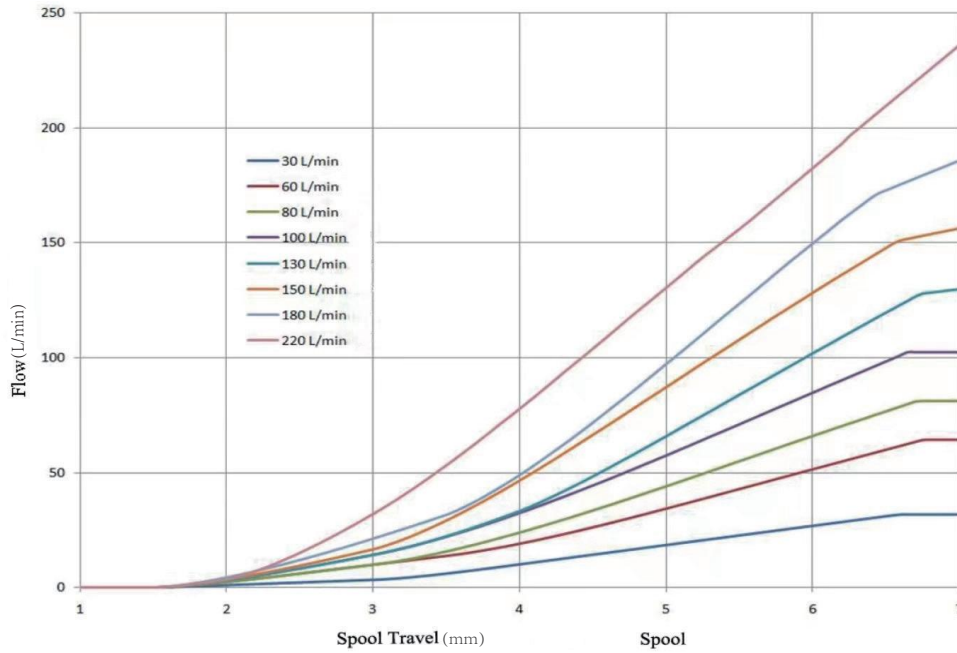

Inlet Section Valve Functions and Schematics

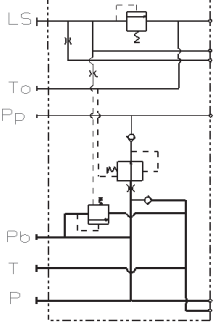
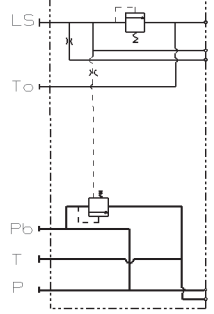
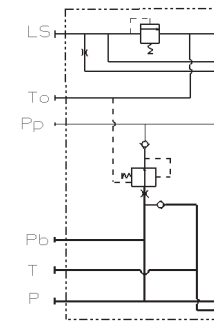
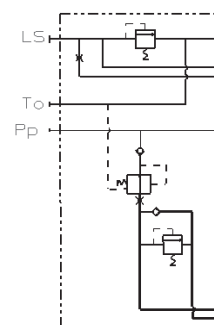
Code	Schematics	Main Functions	Standard Port Sizes
J01		Used in closed circuit fixed displacement pump system, with pilot oil source	LS:M14×1.5, G1/4 TO:M14×1.5, G1/4 T:M27×2, G1 Pp:M14×1.5, G1/4 Pb:M14×1.5, G1/4 P:M27×2, G3/4
J02		Used in closed circuit fixed displacement pump system, manual control, without pilot oil source	LS:M14×1.5, G1/4 TO:M14×1.5, G1/4 T:M27×2, G1 Pb:M14×1.5, G1/4 P:M27×2, G3/4
J03		Used in closed circuit variable displacement pump system, with pilot oil source	LS:M14×1.5, G1/4 TO:M14×1.5, G1/4 T:M27×2, G1 Pp:M14×1.5, G1/4 Pb:M14×1.5, G1/4 P:M27×2, G3/4
J04		Used in closed circuit fixed displacement pump system, without pilot oil source	LS:M14×1.5, G1/4 TO:M14×1.5, G1/4 T:M27×2, G1 Pp:M14×1.5, G1/4 Pb:M14×1.5, G1/4 P:M27×2, G3/4

Inlet Section Valve Functions and Schematics

Code	Schematics	Main Functions	Standard Port Sizes
J05		Used in closed circuits with electronically controlled fixed displacement pumps. Requires external pilot oil source.	LS:M14×1.5, G1/4 TO:M14×1.5, G1/4 T:M27×2, G1 Pb:M14×1.5, G1/4 P:M27×2, G3/4
J06		Used in closed circuits with electronically controlled fixed displacement pumps. Requires external pilot oil source.	LS:M14×1.5, G1/4 TO:M14×1.5, G1/4 T:M27×2, G1 Pp:M14×1.5, G1/4 Pb:M14×1.5, G1/4 P:M27×2, G3/4 Cf:G1/2 LSst:M14×1.5, G1/4
J07		Used in closed circuits with electronically controlled fixed displacement pumps. Requires external pilot oil source.	LS:M12×1.5 TO:M12×1.5 T:M27×2 Pb:M12×1.5 P:M27×2

Inlet Section Dimensions

Standard Inlet Section Dimensions

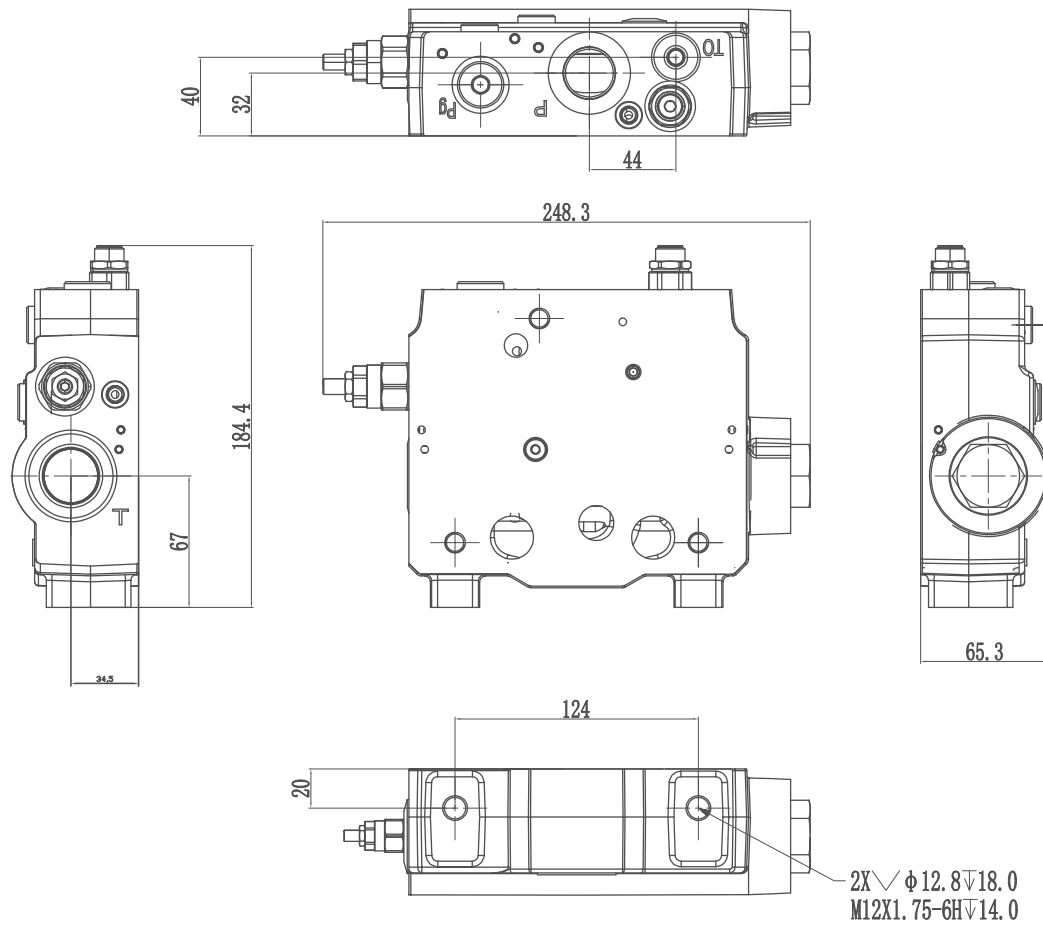

Inlet Section Dimensions

Inlet Section Dimensions with Priority Valve

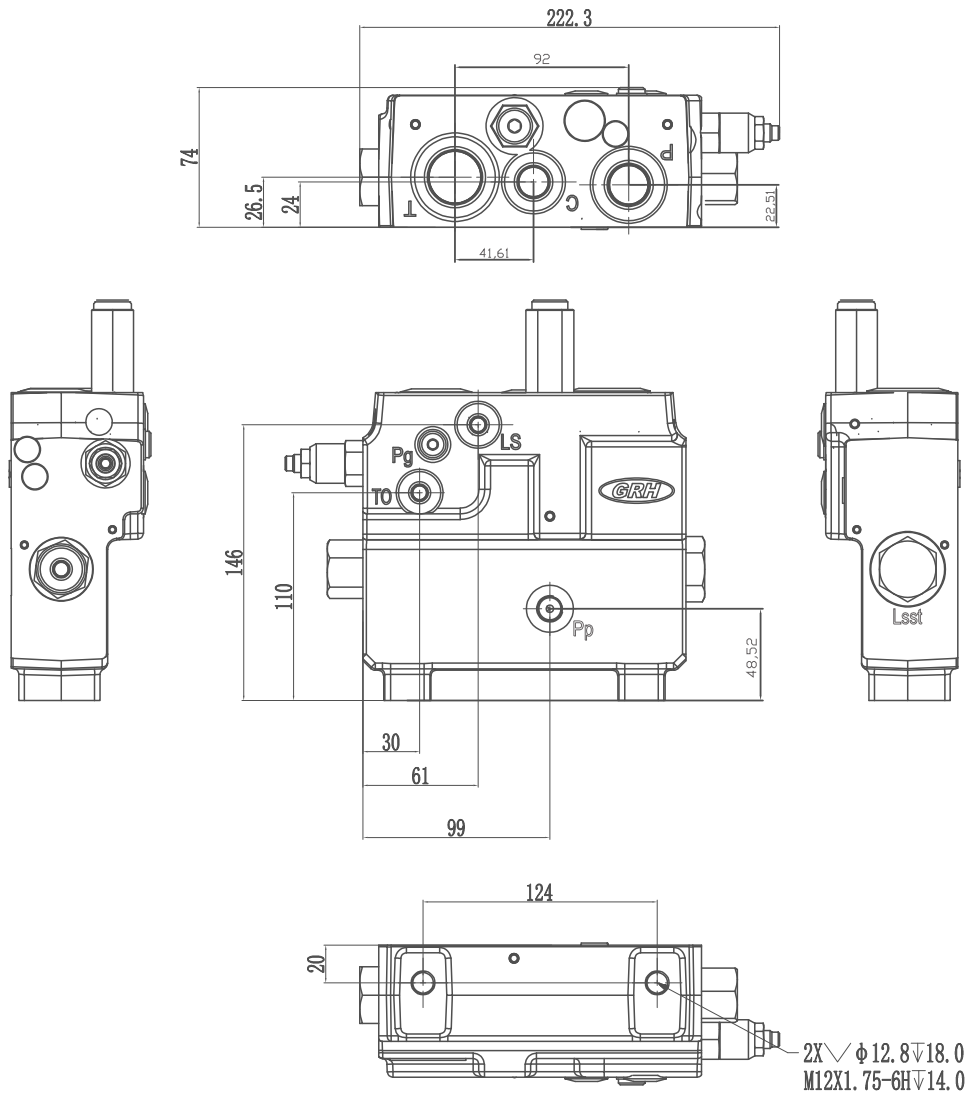

Main Valve Functions and Schematics

Code	Schematics	Main Functions	Notes
Z01		<p>Post-pressure compensation (proportional flow sharing)</p> <p>Basic valve section</p>	
Z02		<p>Post-pressure compensation (proportional flow sharing)</p> <p>Anti-cavitation valve on work ports to prevent cavitations</p>	Commonly used in hydraulic motor applications
Z03		<p>Post-pressure compensation (proportional flow sharing)</p> <p>Provides work ports overload protections and anti-cavitation valve to prevent cavitations</p>	
Z04		<p>Post-pressure compensation (proportional flow sharing)</p> <p>Provides work ports overload protections</p> <p>Provides P.O. checks to hold loads and anti-cavitation valve to prevent cavitations</p>	<p>Most commonly used in cylinder load and holding</p> <p>The P.O. check is used to control load lowering</p> <p>It is also used for swing cylinder and motor</p>

Main Valve Functions and Schematics

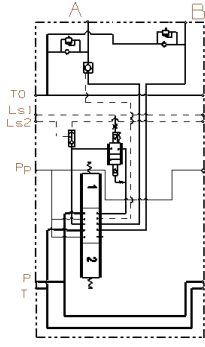
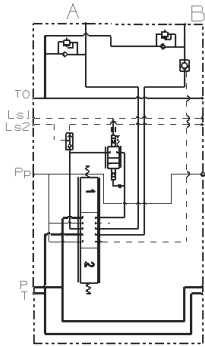
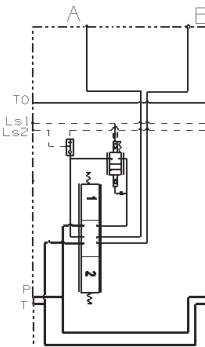
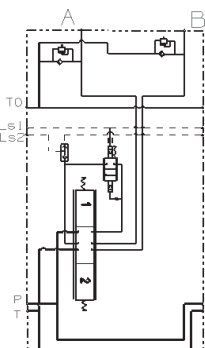
Code	Schematics	Main Functions	Notes
Z05		<p>Post-pressure compensation (proportional flow sharing)</p> <p>Provides work ports overload protections and anti-cavitation valve to prevent cavitations</p>	<p>Most commonly used in cylinder load holding applications</p> <p>The P.O. check is used to control load lowering</p>
Z06		<p>Post-pressure compensation (proportional flow sharing)</p> <p>Provides work ports overload protections and anti-cavitation valve to prevent cavitations</p> <p>Provides P.O. check to hold load on B port</p>	<p>Most commonly used in cylinder load holding applications</p> <p>The P.O. check is used to control load lowering</p>
Z07		<p>Post-pressure compensation (proportional flow sharing)</p> <p>Basic valve section</p> <p>Manually operated</p>	<p>Commonly used in manually controlled proportional valves</p>
Z08		<p>Post-pressure compensation (proportional flow sharing)</p> <p>Provides work ports overload protections and anti-cavitation valve to prevent cavitations</p> <p>Manually operated</p>	

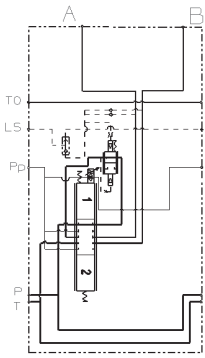
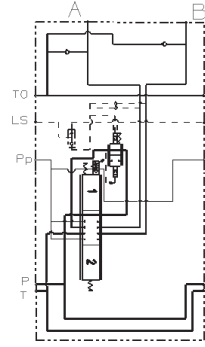
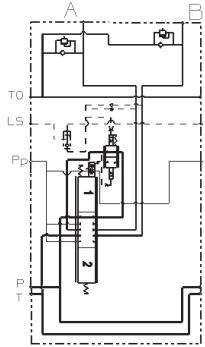
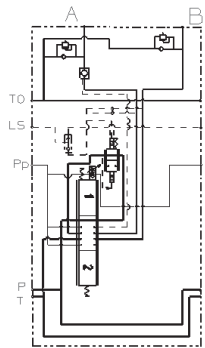

Main Valve Functions and Schematics

Code	Schematics	Main Functions	Notes
Z09		Pre-pressure compensation (proportional flow) Basic valve section	
Z10		Pre-pressure compensation (proportional flow) Anti-cavitation valve on work ports to prevent cavitations	
Z11		Pre-pressure compensation (proportional flow) Provides work ports overload protections and anti-cavitation valve to prevent cavitations	
Z12		Pre-pressure compensation (proportional flow) Provides work ports overload protections and anti-cavitation valve to prevent cavitations Provides P.O. check to hold load on A port	Most commonly used in cylinder load holding applications The P.O. check is used to control load lowering

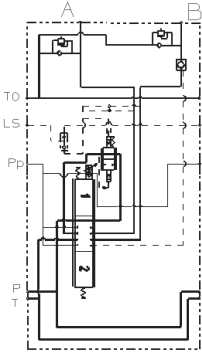
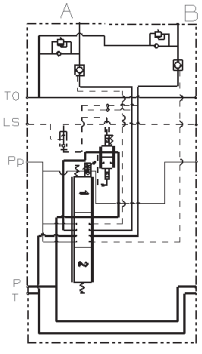
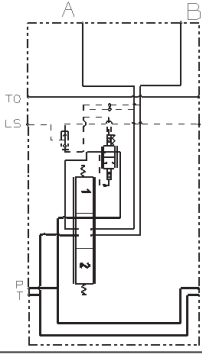
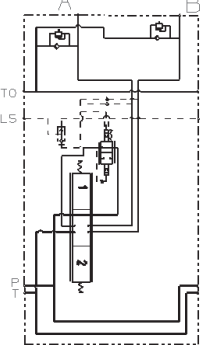

Main Valve Functions and Schematics

Code	Schematics	Main Functions	Notes
Z13		<p>Pre-pressure compensation (proportional flow)</p> <p>Provides work ports overload protections and anti-cavitation valve to prevent cavitation</p> <p>Provides P.O. check to hold load on B port</p>	<p>Commonly used in cylinder load holding applications</p> <p>The P.O. check is used to control load lowering</p>
Z14		<p>Pre-pressure compensation (proportional flow)</p> <p>Provides work ports overload protections and anti-cavitation valve to prevent cavitation</p> <p>Provides P.O. checks to hold loads</p>	<p>Most commonly used in cylinder load holding applications.</p> <p>It is also used for swing cylinder and motor applications</p>
Z15		<p>Pre-pressure compensation (proportional flow)</p> <p>Basic valve section</p> <p>Manually operated</p>	<p>Commonly used manually controlled proportional valve.</p>
Z16		<p>Pre-pressure compensation (proportional flow)</p> <p>Provides work ports overload protections and anti-cavitation valve to prevent cavitation</p> <p>Manually operated</p>	<p>Commonly used manually controlled proportional valve with system protections</p>

End Cap Functions and Schematics

Code	Schematics	Main Functions	Standard Port Sizes
D01		Usually used in closed circuit with variable displacement pump system	T0:M14×1.5, G1/4 T:M33×2, G1 P:M27×2, G3/4
D02		Usually used in fixed displacement pump system	T0:M14×1.5, G1/4 T:M33×2, G1

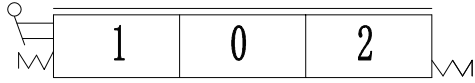
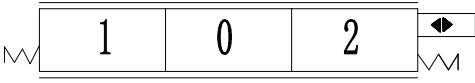
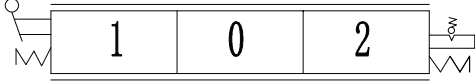
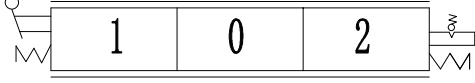
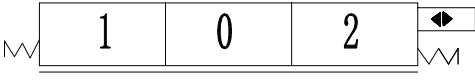
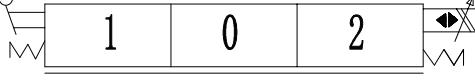
Drive Types for Main Valve Section

Code	Symbol	Functions
Q1		Standard manually operated
Q2		Hydraulic control
Q3		Manually operated with detent
Q4		Manually operated with floating function
Q5		Electric on/off control
Q6		Standard electro-hydraulic proportional control
Q7		Standard electro-hydraulic proportional control with manual override
Q8		Standard electro-hydraulic proportional control with floating function

Main Spool Functions

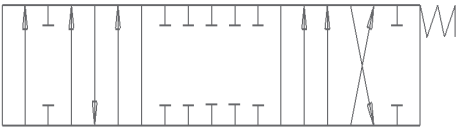
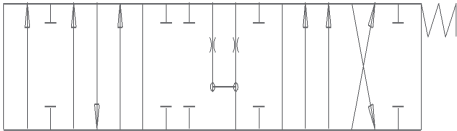
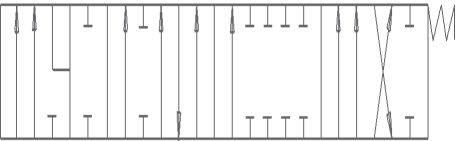
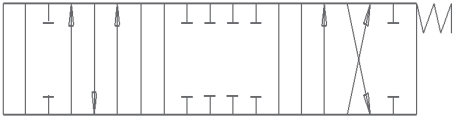
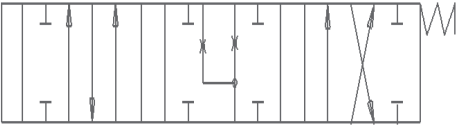
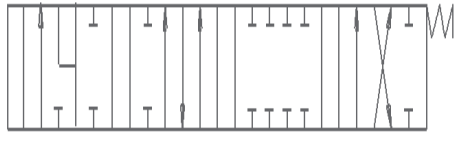
Code	Symbol	Functions	Notes
FG1		Standard 3 position-4 way O type middle function Post-pressure compensation	Commonly used in hydraulic cylinder applications
FG2		3 position-4 way Y type middle function Post-pressure compensation	Commonly used in hydraulic motor applications
FG3		Standard 4 position-4 way O type middle function, with fourth position floating Post-pressure compensation	Commonly used in hydraulic cylinder applications
FG4		Standard 3 position-4 way O type middle function Pre-pressure compensation	Commonly used in hydraulic cylinder applications
FG5		3 position-4 way Y type middle function Pre-pressure compensation	Commonly used in hydraulic motor applications
FG6		Standard 4 position-4 way O type middle function with fourth position floating Pre-pressure compensation	Commonly used in hydraulic cylinder applications

Hydraulic System Examples

Electro-hydraulic proportional control circuit with variable displacement pump
(Post-pressure compensation)

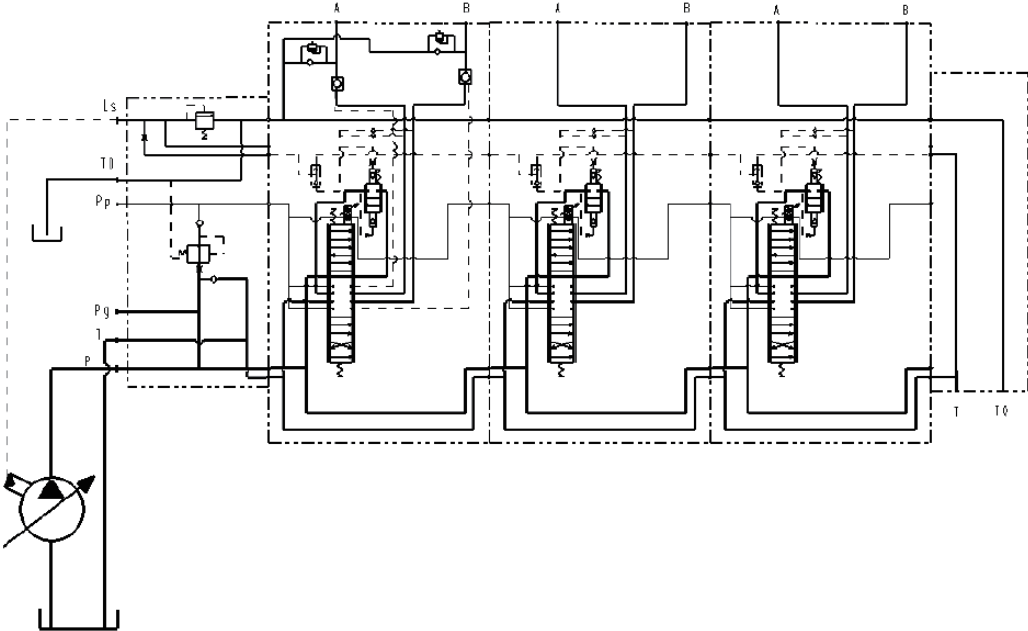

Electro-hydraulic proportional control circuit with fixed displacement pump
(Post-pressure compensation)

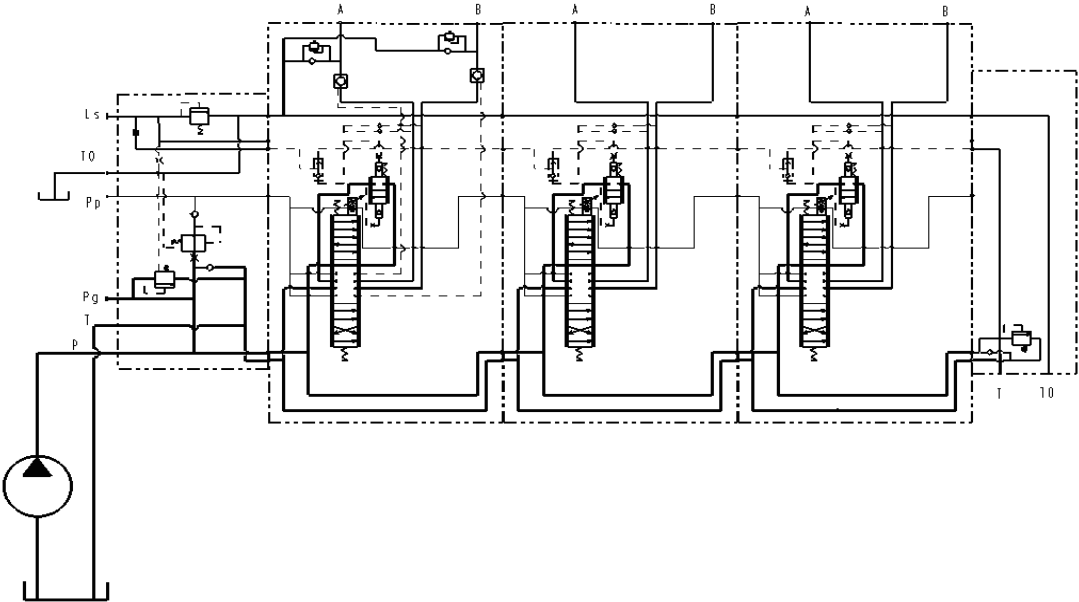

Ordering Code

GBV200	-*	-J**	/***	-D**	-O1	-Z**	Q*	-FG*	-DC/**	-QL/***	-O2	...
a	b	c	d	e	f	g	h	i	j	k	l	m

- | | |
|---|----------------------------------|
| Ⓐ Model | ⓓ Drive style code |
| Ⓑ Number of main section | ⓔ Spool function code |
| Ⓒ Inlet section code | ⓖ Electrical option |
| Ⓓ Relief setting (bar) | 12VDC, 24VDC, 00=none electrical |
| Ⓔ End section code (End cap) without end section use code D00 | ⓓ Expected flow rate |
| Ⓕ First main section | Ⓦ Second section |
| Ⓖ Main section code | ⓓ |

**Port Size: If user do not want our standard size, you have to not only provide ordering code, but also you have to specify all the port sizes.

Ordering Example

GBV200	-3	-J03	/210	-D00	-O1	-Z02	-Q6	-FG1	-DC/24	-QL/100
a	b	c	d	e	f	g	h	i	j	k

- | | |
|---------------------------|---------------------|
| Ⓐ Model | Ⓖ Main section code |
| Ⓑ Three main sections | ⓓ Drive style |
| Ⓒ Inlet code | ⓔ Spool function |
| Ⓓ Relief setting pressure | ⓖ 24VDC |
| Ⓔ No end cap | ⓓ Flow 200L/min |
| Ⓕ First section | |

-O2	-Z01	-Q6	-FG1	-DC/24	-QL/180
l	m	n	o	p	q

-O3	-Z01	-Q6	-FG1	-DC/24	-QL/130
r	s	t	u	v	w

① Second section

Ⓜ Main section code

Ⓝ Drive style code

Ⓞ Spool function code

Ⓟ 24VDC

Ⓠ Flow 180L/min

Ⓡ Third section

Ⓢ Main section code

Ⓣ Drive style code

Ⓤ Spool function code

Ⓡ 24VDC

Ⓢ Flow 130L/min

Order example notes: From system example, the valve selected is GBV200 series, we know that the valve has three cap. (Return is from inlet section.) Inlet relief valve setting pressure is 21MPa. There is no end section. The first section has no load relief valve. The section is driven by 24VDC coils. The spool middle function is a O type. The required flow is 200L/min. The second section is also driven by 24VDC coils. There is no overload relief on neither A or B port. The spool middle function is O type, The required flow for the 180L/min. The third section is driven by 24VDC coils. No overload relief on neither A or B port. Spool middle function is O type, the required flow is



Shanghai Guorui Hydraulic Technology Co., Ltd

Add. Room 2201, 1717 North Sichuan Road,
Hongkou Shanghai, China
P.C. 200080
Tel. +86-21-6218 3268
Mail. info@grhcn.com

Add. 666 West Shuanghu Road, Hi-tech Zone,
Jianhu Yancheng, Jiangsu, China
P.C. 224700
Tel. +86 0515-86316688 +86 400 188 1986
Mail. info@grhpro.com

